

Lemi[®]
ITALIAN WELLNESS EQUIPMENT



DERMAT
MEDICAL SUPPLIES

016/ 40 05 45
info@dermat.be
www.dermat.be

GINECOLOGIA

GYNAECOLOGY



COD. 301

Hydrogyno is specifically designed for diagnostics, gynecological, ultrasound and colposcopic examinations. Equipped with standard anatomic mattress. Upon request, the version with removable legrest allows the chair to become a functional examination bed. Suitable for any kind of medical room partly thanks to 360° rotation.

Hydrogyno è la poltrona progettata per esami diagnostici, ginecologici e colposcopici. Dotato di materasso anatomico standard. Su richiesta, la versione con poggiatesta rimovibile consente alla poltrona di diventare un lettino funzionale. Indicato per ogni spazio medico anche grazie alla rotazione di 360°.

Focus on

- Hydraulic pump for height adjustment
- Manual backrest and trendelenburg adjustment
- 360° rotation
- "Easy-to-clean" mattress with seat hole
- Wide selection of class 1IM fire-resistant coverings
- Removable legrest available upon request
- Standard version includes: stainless steel basin for organic waste, thigh support couple, seat guides couple, fixed clamps couple, stainless steel handles and roll holder
- Pompa idraulica per la regolazione dell'altezza
- Regolazione manuale di schiena e trendelenburg
- Rotazione 360°
- Materasso "easy-to-clean" con foro seduta
- Ampia scelta di rivestimenti ignifughi classe 1 IM
- Gamba estraibile disponibile su richiesta
- La versione standard include: vaschetta in acciaio inossidabile per rifiuti organici, coppia di reggicoste, coppia guide seduta, coppia morsetti fissi, maniglie in acciaio inossidabile e portarotolo

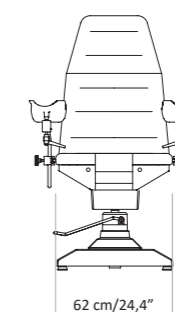
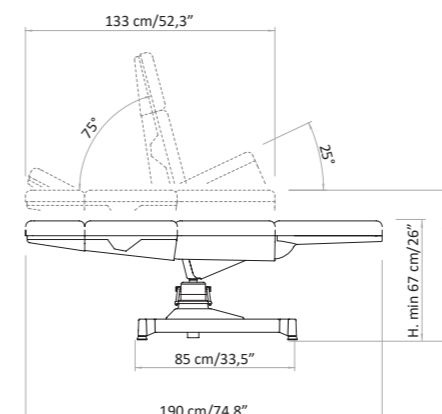

Packaging details

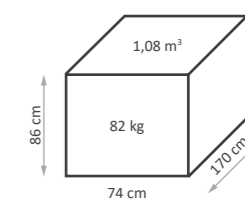

MAXIMUM CAPACITY
PORTATA MASSIMA
150 kg

MOVEMENTS

1 movement by oleodynamic pump: height

3 manual movements: backrest, trendelenburg, extractable legrest

360° Chair rotation

MOVIMENTI

1 movimento con pompa idraulica: altezza

3 movimenti manuali: schiena, trendelenburg, gamba estraibile

Rotazione poltrona 360°



Anatomic seat with a practical stainless steel bowl
16,3 x 10,3 x 4,4h cm - 6,4"x 4"x 1,7"h
Seduta con foro con pratica vaschetta inox
16,3 x 10,3 x 4,4h cm - 6,4"x 4"x 1,7"h

67-83 cm
(26"-33")

Height adjustment by oleodynamic pump
Regolazione altezza con pompa idraulica



25°

Manual Trendelenburg
Trendelenburg manuale



75°

Manual backrest
Schiena manuale



Removable legrest
(upon request)
Gamba estraibile
(su richiesta)



360°

180° rotation on both sides
Rotazione 180° da entrambi i lati

BASE CUSTOMIZATION

We provide a thermoformed ABS base, completely closed to prevent any infiltration of powders or liquids. It is a very hard material, scratch-proof resistant and easy-to-clean.

PERSONALIZZAZIONE BASE

Forniamo una base in ABS termoformato, completamente chiuso per evitare qualsiasi infiltrazione di polveri o liquidi. È un materiale molto duro, resistente ai graffi e facile da pulire.

MATTRESS CUSTOMIZATION

Nefos is the exclusive upholstery line by Lemi. The innovative material and its special finishing touch guarantee easy-cleaning and hygiene. Its extraordinary structural qualities will persist through the years. An incredibly elastic texture enhances the memory foam mattress softness and quality at its best.

PERSONALIZZAZIONE MATERASSO

Nefos è la linea di rivestimento esclusive di Lemi. L'innovativo materiale e il suo speciale tocco di finitura garantiscono una facile pulizia e igiene. Le sue straordinarie qualità strutturali permangono nel corso degli anni. Una texture incredibilmente elastica migliora al massimo la morbidezza e la qualità del materasso in Memory Foam.

Available finishing for HYDROGYNO Finiture disponibili per HYDROGYNO



White
Bianco



Grey
Grigio



Black
Nero

NEFOS COLORS

COLORI NEFOS



The images are for illustrative purposes only and may not reflect the actual finish of the product, particularly when viewed through a screen. Therefore, the **SELECTION OF THE MATTRESS FABRICS** must take place **AFTER CONSULTING** the **PHYSICAL SAMPLES** in the **NEFOS COLOR CHART**.



Le immagini hanno valore puramente illustrativo e possono non rispecchiare la finitura reale del prodotto, in particolare se visualizzate attraverso uno schermo. Pertanto la **SELEZIONE DEI RIVESTIMENTI DEI MATERASSI** deve avvenire **PREVIA CONSULTAZIONE** della **CAMPIONATURA FISICA** nella **CARTELLA COLORI NEFOS**.

ACCESSORIES UPON REQUEST ACCESSORI SU RICHIESTA

All Medical chairs have a standard setting customizable upon request.

Tutte le poltrone Medicali hanno una configurazione standard personalizzabile su richiesta.



I.V. Rod
(fixed with rotatable clamp and guides on the back)
Asta portaflebo
(da fissare con morsetto girevole e guide schiena)



Heel support couple
(fixed with fix clamp and guides on the seat)
Coppia reggitallone
(da fissare con morsetti fissi e guide sulla seduta)



Fixed clamp
Morsetto fisso



Wheels with brake (ø 50mm)
Ruote con freno (ø 50mm)



Rotatable clamp
Morsetto girevole



GYNO Lamp
Lampada GYNO



Medical armrest couple (to be fixed with rotatable clamp and guides on the back)
Coppia braccioli medicali
(da fissare con morsetti girevoli e guide schiena)



Inox tray with support (fixed with fix clamp and guides on the seat)
Vassoio inox completo di telaio (da fissare con morsetto fisso e guide seduta)

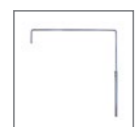

Curtain holder
(fixed with rotatable clamp and guides on the back)
Reggitelo
(da fissare con morsetto girevole e guide schiena)



UK cable
Cavo UK



Leg support
Supporto gamba



USA cable
Cavo USA



Back guide couple
Coppia guide schiena

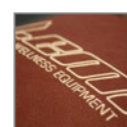

Customization with logo
Personalizzazione con logo



Colposcope support
Supporto colposcopio

TECHNICAL REQUIREMENTS

CARATTERISTICHE TECNICHE

ELECTRIC REQUIREMENTS / CARATTERISTICHE ELETTRICHE

VOLTAGE VOLTAGGIO	FREQUENCY FREQUENZA	ABSORPTION ASSORBIMENTO	TRANSFORMER TRASFORMATORE	PROTECTION RATING GRADO DI PROTEZIONE	ELECTRIC SYSTEM CONFORMS TO CEI NORMS IMPIANTO ELETTRICO a norme CEI	CONTROL BOX CENTRALINA
230/110V ac	50/60 Hz	0,7 - 1 A max	120 Va	IP 54	4	class II classe II

TECHNICAL SPECIFICATION / SPECIFICHE TECNICHE

MINIMUM HEIGHT: 67 CM / 26"

MAXIMUM HEIGHT: 83 CM / 33"

ANGLE OF INCLINATION TRENDELENBURG: 25°

ANGLE OF INCLINATION BACK REST: 75°

MATTRESS LENGTH: 136 CM / 58"

MATTRESS LENGTH WITH LEGREST: 190 CM / 75"

MATTRESS WIDTH: 62 CM / 24"

ROTATION: 360°

LATEX-FREE, NON-TOXIC AND NON-CARCINOGENIC MATERIALS

FIRE-RESISTANT UPHOLSTERY: UNI 9175 CLASS I M

ALTEZZA MINIMA: 67 CM

ALTEZZA MASSIMA: 83 CM

ANGOLO INCLINAZIONE TRENDELENBURG: 25°

ANGOLO INCLINAZIONE SCHIENA: 75°

LUNGHEZZA MATERASSO: 136 CM

LUNGHEZZA MATERASSO GAMBE ESTESE: 199 CM

LARGHEZZA MATERASSO: 62 CM

ROTAZIONE: 360°

MATERIALI PRIVI DI LATTICE, ATOSSICI E NON CANCEROGENI

RIVESTIMENTO IGNIFUGO: UNI 9175 CLASS I M

WARRANTY / GARANZIA

STRUCTURE: 10 YEARS

MOTORS AND CONTROL: 2 YEARS

CUSHION: 5 YEARS

STRUTTURA: 10 ANNI

MOTORI E CONTROLLI: 2 ANNI

MATERASSO: 5 ANNI

LEMI MATTRESSES

The MATTRESSES of the LEMI GYNO line are made with the best quality materials to ensure maximum comfort for both the patient and the doctor.

MATERASSI LEMI

I MATERASSI della linea GINECOLOGICA LEMI sono realizzati con materiali della migliore qualità per garantire il massimo comfort sia per il paziente che per il medico.



GYNO PLUS

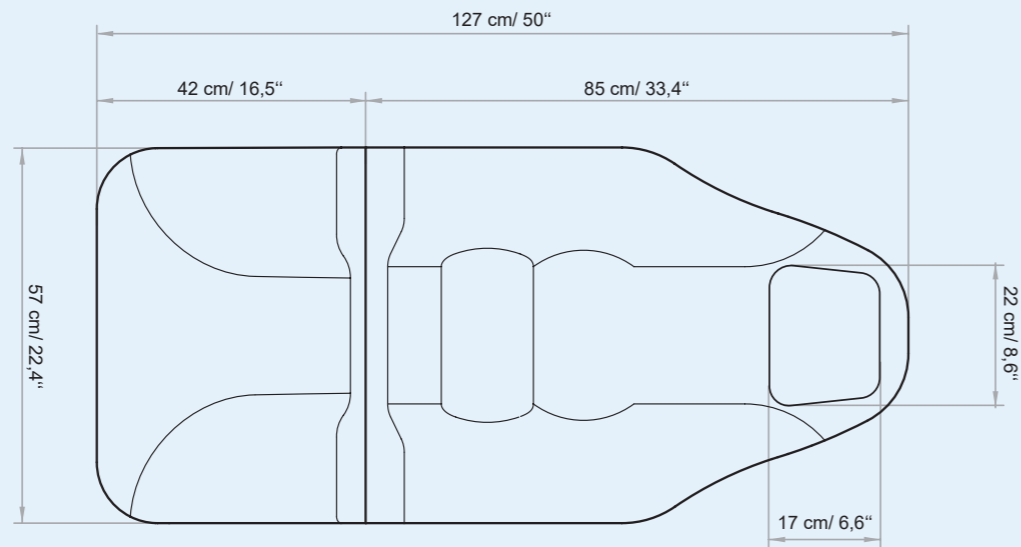

GYNO

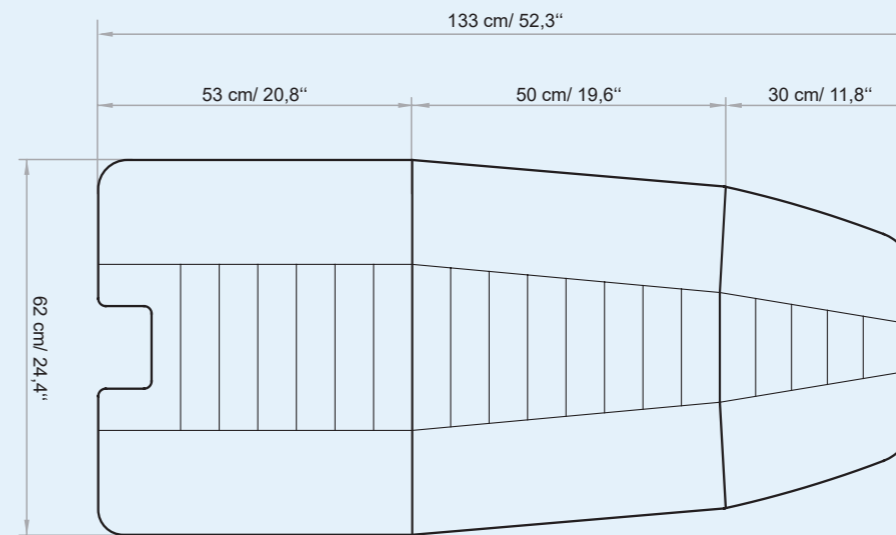

FOOT SUPPORT

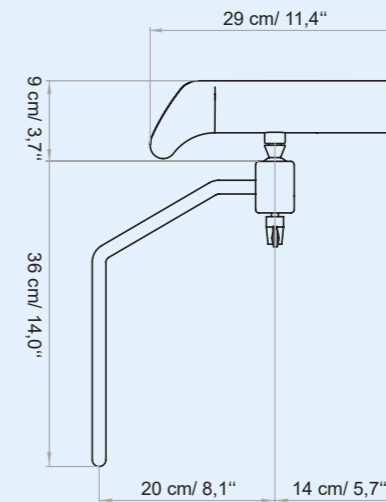
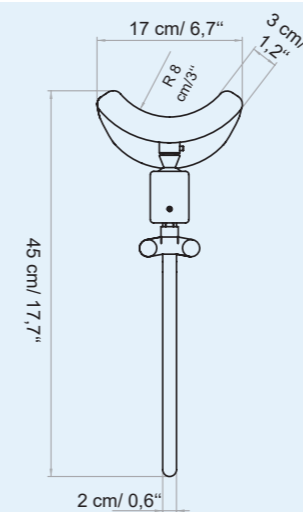
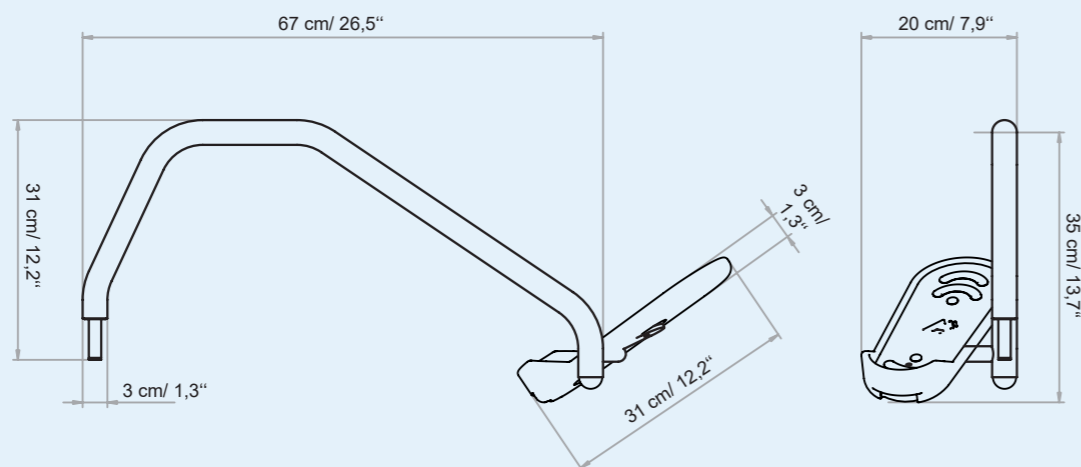

THIGH SUPPORT



REGULATIONS

All Equipment is  marked

Electrical equipment and beds

Directive 2006/42/CE (Machinery Directive) and national regulations
Directive 2014/30/UE (Electromagnetic Compatibility Directive) and national regulations.

Hydraulic equipment and beds

Directive 2006/42/CE (Machinery Directive) and national regulations

Images

The images are for illustrative purposes only and may not reflect the actual image of the product.

NORME

Tutte le attrezzature sono a marchio 

Attrezzature e lettini elettrici

Direttiva 2006/42/CE (Direttiva Macchine) e disposizioni nazionali di attuazione
Direttiva 2014/30/UE (Direttiva Compatibilità elettromagnetica) e disposizioni nazionali di attuazione.

Attrezzature e lettini idraulici

Direttiva 2006/42/CE (Direttiva Macchine) e disposizioni nazionali di attuazione

Immagini

Le immagini hanno valore puramente illustrativo e possono non rispecchiare l'immagine reale del prodotto.

Lemi[®]
ITALIAN WELLNESS EQUIPMENT

Brusaferrì & C srl

Via Mara Maretti Soldi, 13
26011 Casalbuttano (CREMONA) ITALY
Phone +39-0374-363069 Fax +39-0374-363071
info@lemigroup.it service@lemigroup.it

www.lemigroup.it