

QA3

Emergency Trolley

Radiotranslucent platform with exceptional X-ray access and low height capability

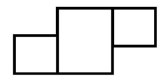

DERMAT
MEDICAL SUPPLIES

016/ 40 05 45

info@dermat.be

www.dermat.be



AneticAid

QA3 EMERGENCY TROLLEY SYSTEM: Four new models to choose from



QA3
Emergency Trolley

QA3
Emergency Trolley

Specially designed for Emergency Departments with radiolucent platform, offering exceptional X-ray access as well as a medirail and K8 pressure care mattress.

Description	Code
QA3 Emergency Trolley with Radiolucent Platform	21120



QA3
DRIVE
Emergency Trolley

QA3 DRIVE
Emergency Trolley

Featuring inbuilt motorised drive – operated by innovative touch-sensitive pushing handles: controlled, effortless travel up to gradients of 10°

Description	Code
QA3 DRIVE Emergency Trolley with Radiolucent Platform	21122



QA3
Emergency Trolley

QA3
Powered ⚡ Emergency Trolley

Electrically powered positioning raises or lowers trolley platform or backrest – effortlessly. Special feature swiftly returns trolley to horizontal, optimal height position for CPR treatment.

Description	Code
QA3 Powered Emergency Trolley with Radiolucent Platform	21126



QA3
DRIVE
Emergency Trolley

QA3 DRIVE
Powered ⚡ Emergency Trolley

Top of the range model: combines all features of the Standard, DRIVE and Powered trolleys – the complete answer for moving and positioning patients as easily as possible.

Description	Code
QA3 DRIVE Powered Emergency Trolley with Radiolucent Platform	21124

Quick reference guide to your QA3 Emergency Trolley options:

QA3 Emergency Trolley	STANDARD FEATURES
QA3 DRIVE Emergency Trolley	STANDARD FEATURES plus INBUILT MOTORISED DRIVE
QA3 Powered ⚡ Emergency Trolley	STANDARD FEATURES plus POWERED FUNCTIONS
QA3 DRIVE Powered ⚡ Emergency Trolley	STANDARD FEATURES plus INBUILT MOTORISED DRIVE and POWERED FUNCTIONS

Specialist Bariatric option of any model available: see page 10

Contents

Standard features	4-5
DRIVE features	6-7
Powered features	8-9
Build Options including Bariatric Trolley	10-11
Accessories	12-13
AnetiCare	14-15



Combining industry knowledge with innovative technology



Designed and produced at our UK manufacturing facility using the latest engineering techniques



Manufacturer, designer and supplier of high quality medical equipment around the world

STANDARD FEATURES

QA3
Emergency Trolley

QA3//DRIVE
Emergency Trolley

QA3
Powered Emergency Trolley

QA3//DRIVE
Powered Emergency Trolley

Specially designed QA3 Emergency Trolley features a radiotranslucent platform, exceptional X-ray access and low height capability. Comes complete with a medirail and the K8 pressure care mattress.

With maximum patient comfort built in, the trolley is supremely manoeuvrable, compact, light weight and robust. All Emergency trolleys are fitted with two fixed transfusion poles and a medirail.



Trendelenburg tilt

extremely smooth and controlled mechanism, even at lowest height

Vertically operated side rails

store away under mattress for a virtually zero transfer gap. Spring counterbalancing allows effortless ease of operation

5th wheel steering

unique mechanism ensures maximum manoeuvrability and easily guided by one person

Patient comfort

exceptional low height capability and store away side rails allow easy mount/dismount particularly for frail and elderly patients. Wide patient platform and pressure care mattress for patient comfort. Optimum ground clearance for patient hoist access



Pushing handles

four ergonomically positioned pushing handles for supreme manoeuvrability

Gas assisted backlift

unique design, precision controlled, easy lift system for enhanced user and patient comfort

Infection control

smooth moulded surfaces and acrylic capped vac formings enclose trolley mechanics to minimise dirt traps. Anti-bacterial properties and innovative design for easy cleaning

Castors

polyurethane tyres offer low rolling resistance for high manoeuvrability, 150mm castors fitted as standard, 200mm optional

Cylinder trough

side loading for ease of access, suitable for wide range of cylinder options including F, E or CD



K8 pressure care mattress

manufactured from temperature-sensitive gel feel foam that moulds to the patient's body shape, relieving pressure by distributing the load as evenly as possible. Outer material is anti-microbial, water resistant, vapour permeable and latex free

X-ray translucent platform

full length radiotranslucent platform, suitable for digital or traditional plates

Two fixed transfusion poles

fitted as standard: innovative quick release safety locking mechanism, integrates into either head or foot end of side rails for easy access and storage

Hydraulic lift mechanism

exceptional low height capability, adjusted by independently operating pedals on both sides of trolley



Special bariatric version of this model also available – see page 10



Motorised **DRIVE** FEATURES

QA3
Emergency Trolley

QA3 **DRIVE**
Emergency Trolley

QA3
Powered Emergency Trolley

QA3 **DRIVE**
Powered Emergency Trolley

Inbuilt motorised drive offers effortless movement combined with ultimate control.

Because people and therefore patients are getting larger, it's crucial that we take moving and handling issues into account, giving practitioners a trolley on which patients can be moved and positioned as easily as possible.

The introduction of our new touch-activated, motorised DRIVE feature offers a major enhancement in a trolley that already has ease of use, practicality and patient comfort built in.

The trolley can also be used in traditional fifth wheel steer mode.



DRIVE handles

innovative touch sensitive design: simply press against the pop-up or fixed yellow pushing handles, and the trolley will move forward; pull back on them, and it will reverse; let go and it will stop



Effortless travel up to gradients of 10°



Inbuilt motorised drive

no need to push or pull the trolley: our new, inbuilt motorised DRIVE feature linked to the trolley's 5th wheel, offers controlled, effortless travel up to gradients of 10°

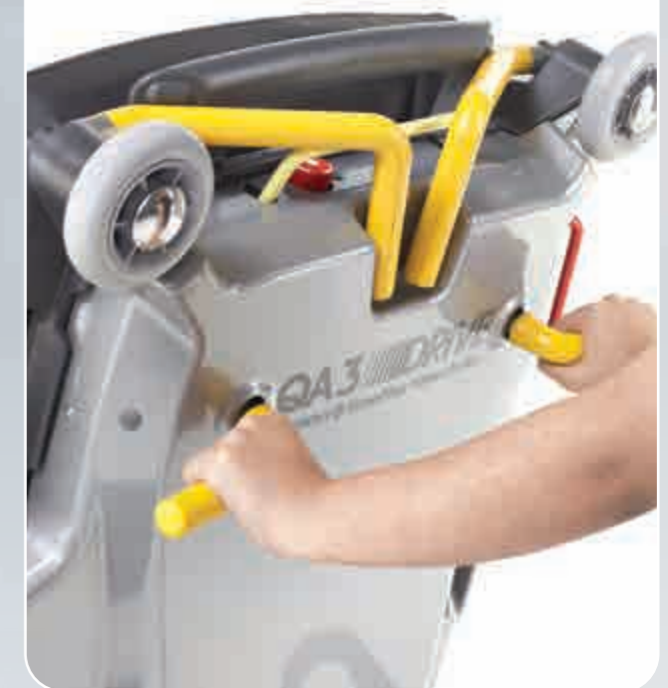

Long-life battery – 22 kilometers on a single charge

DRIVE feature powered by advanced nickel-metal hydride rechargeable battery



Highly accurate battery charge indicator – rapid charge



DESIGN & INNOVATION



MADE IN THE UK



GLOBAL DISTRIBUTION

Motorised DRIVE: effortless travel, ultimate control

Powered ⚡ FEATURES

QA3
Emergency Trolley

QA3 // // // DRIVE
Emergency Trolley

QA3
Powered ⚡ Emergency Trolley

QA3 // // // DRIVE
Powered ⚡ Emergency Trolley



Another option developed to help minimise risks for practitioners dealing with increasing patient weights is powered positioning.

With these models, either the whole trolley platform or the backrest can now be raised or lowered electronically from the panel at the foot end.

There's also a special CPR feature: return the trolley swiftly to a horizontal, optimal height position for CPR treatment, at the touch of a button.

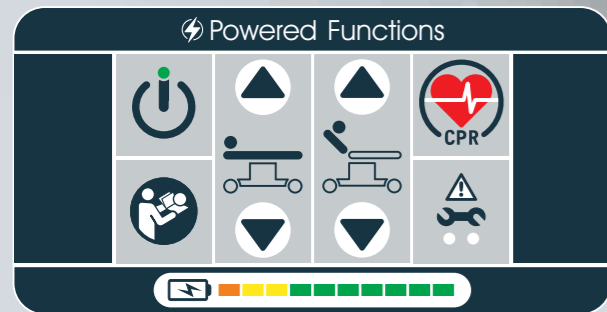

Electrically Powered Functions
easy to operate using the positive feel push button controls on a panel at the foot of the trolley
Manual override systems as standard

Platform height – electrically powered raise and lower mechanism

Offers smooth movement to position the trolley at any point in its height range – 535mm to 835mm (excluding mattress)

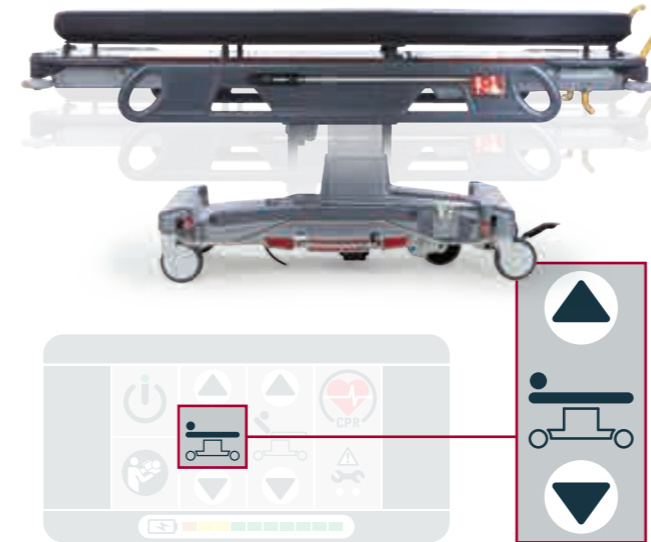

Backrest – electrically powered raise and lower mechanism

Positions the backrest anywhere between the vertical and horizontal for maximum patient comfort

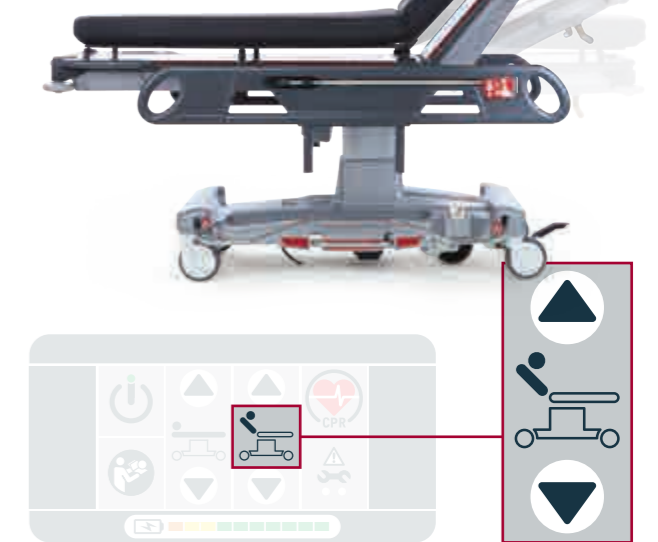

Lights on the power panel illuminate to refer the user to the manual if the equipment is being used incorrectly or to indicate when maintenance is required

If a patient needs CPR treatment, there is no time to lose: the powered CPR feature returns the trolley swiftly to a horizontal, optimal height position for CPR treatment

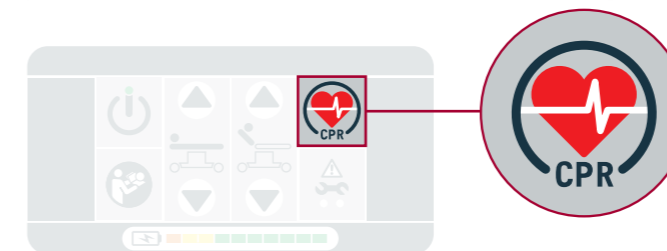

Trendelenburg – hydraulically powered tilt mechanism

Extremely smooth and controlled movement, even at the trolley's lowest height



Special features for a trolley that's more powerful, by design



BUILD OPTIONS

QA3 <800> for Bariatric Patients

Increased platform/mattress – width: 800mm

Again recognising the trend for increasing patient weights and sizes, we offer special Bariatric versions of the QA3.

The extra wide (800mm) platform significantly increases the surface area for added safety and comfort for Bariatric patients.



As with all of our trolleys, the QA3 <800> is fitted with a K8 pressure care mattress.

Specially developed for this Bariatric trolley, the mattress core is made of high density foam, moulded with a unique castellated surface. This increases air flow within the mattress and helps to relieve pressure by distributing the patient's weight as evenly as possible across the surface area – particularly important for heavier patients.

Like other K8 models, the foam has antibacterial and microbial fungistatic properties and its latex-free, 4-way stretch polyurethane (PU) outer cover allows the skin to breathe – for greater patient comfort.

Finally, our unique ultrasonic sealing system effectively welds the seams of the outer cover material together to give an almost unbreakable seal, making the K8 a class leader in infection control.

 All models of the QA3 Emergency Trolley have a weight capacity of 320kg and can be fitted with this increased platform width

Description	Code
QA3 Build Option <800>	22160
800mm Extended Width Patient Platform	

QA3
Emergency Trolley

QA3//DRIVE
Emergency Trolley

QA3
Powered Emergency Trolley

QA3//DRIVE
Powered Emergency Trolley



21191



21159



21175



21393



21175-C2



21175-C3



21175-C4



21175-C5

Description	Code
200mm Castors	21132
Reverse Trendelenburg QA3/QA4M	21135
Transfusion Poles x2 for Monitor Shelf	21152-B1
QA3 / QA4 Paper Roll Holder (up to 620mm wide) Universal	21159
Additional Transfusion Pole, Fixed	21161
Department Identification	21175
Colour ID Labelling – BLUE	22175-C2
Colour ID Labelling – GREEN	22175-C3
Colour ID Labelling – YELLOW	22175-C4
Colour ID Labelling – GREY	22175-C5
Patient's Storage Container	21191
Oxygen Cylinder Bracket for CD Systems c/w Backing Plate	21393

Factory Fitted Build Options

Build Options must be specified at the time of ordering



Specialist build options available



ACCESSORIES

K8 Pressure Care Mattresses

Pressure care and infection control are top priorities in a trolley mattress – and Anetic Aid’s independently tested K8 pressure care mattress addresses both of these vital factors.

At its core is high density foam, uniquely specified by Anetic Aid. This means that the mattress can be thinner, while still offering the same, if not better, pressure distribution than a thicker, less sophisticated foam. This is particularly important with tables and trolleys, as it means the overall height can be kept as low as possible for easy access by frail or elderly patients.

A layer of thermally responsive gel-feel memory foam is then added, further relieving pressure by distributing the patient’s weight as evenly as possible across the surface area – whatever their position.



Infection control

Both of the foam elements of the mattress have antibacterial and microbial fungistatic properties, while its latex-free, 4-way stretch polyurethane (PU) outer cover is anti-microbial, water resistant and vapour permeable. This means it is not only contamination-resistant, but it also allows the skin to breathe – for greater patient comfort.

Finally, a unique ultrasonic sealing system effectively welds the seams of the outer cover material together to give an almost unbreakable seal, making the K8 a class leader in infection control.

In the science of Kinetics, there are eight points of contact the human body makes when lying on a hard surface – hence K8.

Description	Code
QA3 K8 Pressure Care Mattress with Zip Cover	21186
QA3 K8 Pressure Care Mattress – Replacement Waterproof Zip Cover	21186-B1

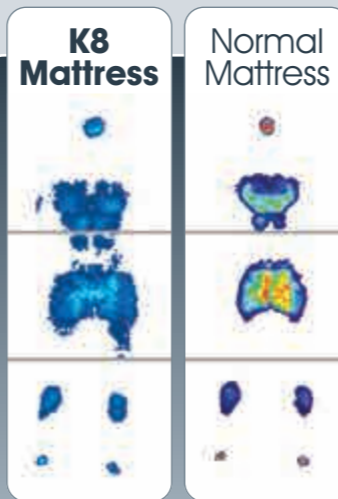

Anetic Aid’s K8 technology mattresses can be found in over 90% of NHS hospitals in the UK.

- High risk pressure care mattress
- Independently tested
- Latex free
- Antibacterial/vapour permeable
- Welded seams
- X-ray translucent

QA3
Emergency Trolley

QA3//DRIVE
Emergency Trolley

QA3
Powered Emergency Trolley

QA3//DRIVE
Powered Emergency Trolley



21143 21144-A1

Connectors and bracketry for suction systems

Suction system accessories

Description	Code
QA3 Medirail Bracketry for SOS System	21130/5
Suction – Injector and Probe for CD and HX Cylinder (complete)	21143
Suction – SOS Unit c/w 90° O ₂ Connector	21144
Suction – Single Stage Medireg and Schrader – Bullnose O ₂	21144-A1

Padded Side Rails

Description	Code
QA3 Side Rail Covers, Grey (pair)	21172
QA3 Side Rail Covers, Child Print (pair)	21173



Additional products for all QA3 Trolley models

Specially designed and manufactured accessories for QA3 Patient and Emergency Trolley Systems.

Description	Code
Monitor Shelf c/w Removable Refreshment Tray	21152
Refreshment Tray ONLY	21152-A1
QA3 Foot-end Extension c/w 100mm Pad	21153
Theatre Pillow c/w QA3 Mattress Retention Strap	21188
QA3 Foot-end Mattress Protector	21189
QA3 and QA4 Trolley Systems Push / Pull Bar	21390

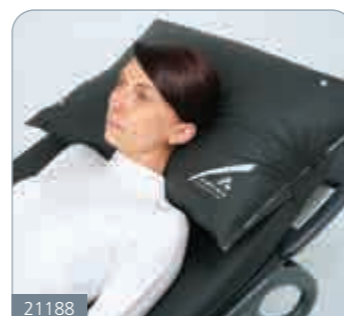

Accessories for radiographers

As well as our Lateral Cassette holder, we offer three additional items to aid patient positioning and help radiographers achieve the best possible image outcomes.

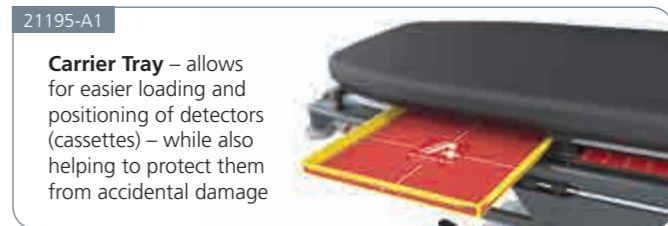

Carrier Tray – allows for easier loading and positioning of detectors (cassettes) – while also helping to protect them from accidental damage



Wallace Support – facilitates positioning of cassette for Modified Axial (Wallace) View patient shoulder X-rays. Consists of two props which attach to Side Rail with spring-loaded quick release handles



Support Shelf – for easy and secure positioning of cassette for patient chest X-rays

Description	Code
QA3 Lateral Cassette Holder	21192
QA3 Emergency Trolley Radiographic Cassette Carrier Tray	21195-A1
QA3 Emergency Modified Axial (Wallace) View Support	21195-B1
QA3 Emergency Trolley X-ray Cassette Support Shelf	21195-C1

Wide range of extra items to complement any QA3 Emergency Trolley





LIFETIME WARRANTY

Subject to annual servicing

QA3 Trolley System:
we offer the unique
and popular
'Lifetime Warranty Scheme'

Take out a service package for regular
maintenance costs, fixed for 10 years, including a
10 YEAR WARRANTY

Covers engineer's time and
most parts – also ask about our **AnetiCare**
maintenance programmes

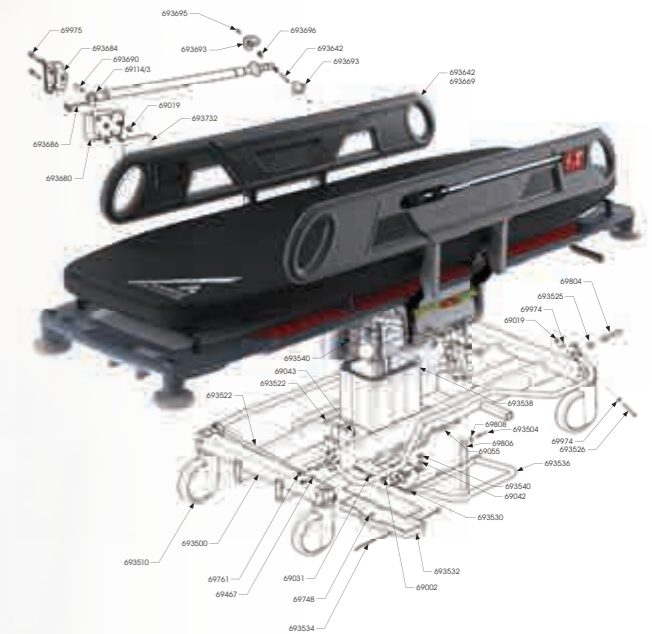

DESIGN & INNOVATION



MADE IN THE UK



GLOBAL DISTRIBUTION

Value for money: minimum downtime, maximum peace of mind



QA3

Emergency Trolley

Specifications

Overall length:
2150mm

Overall width:
835mm (side rails up)
735mm (side rails down)

Height range excluding mattress:
535mm to 835mm

Trolley weight:
148kg (21120)
157kg (21122)
154.5kg (21126)
162.5kg (21124)

Maximum patient weight:
320kg (Please refer to user manual)

Please refer to 'Instructions for Use' for full product specification details

Standard features

X-ray translucent platform – full length radiotranslucent platform, suitable for digital or traditional plates

Hydraulic lift mechanism – exceptional low height capability

Vertically operated side rails – giving a virtually zero transfer gap

Trendelenburg tilt – extremely smooth and controlled mechanism

Latest castor technology – low rolling resistance for high manoeuvrability

5th wheel steering – easily guided by one person

Pushing handles – ergonomically positioned

Gas assisted backlift – horizontal to near vertical

Advanced braking system – exceptionally stable platform

Two fixed transfusion poles – innovative quick release

Cylinder trough – side loading

K8 pressure care mattress – body mould foam, anti-bacterial and latex free

Rotating buffers – at head and foot ends

Infection control – anti-bacterial properties and smooth moulded surfaces



For more information on any of our products or service contracts, call:

T +44 (0)1943 878647

sales@aneticaid.com

aneticaid.com

Innovative medical technology – practically applied

SPECIALISING IN:

Patient & Surgery Trolley Systems

Operation Table Accessories

Stainless Steel Theatre Furniture

Radiation Protection

Electro-Surgical Accessories

Tourniquet Systems

Fibre Optic Instruments

Service & Maintenance



MADE IN THE UK



AneticAid

Anetic Aid Ltd.

Sapper Jordan Rossi Business Park, Otley Road, Baildon BD17 7AX, UK