



CHEMOTECHNIQUE DIAGNOSTICS

President's message

Looking back to 1981 when I first committed to the world of patch testing it is hard not to marvel at the progression made in the field.

During the four decades I have been part of the patch testing community I have witnessed how the discipline has grown from a niche activity performed by a relative few specialists with a deep understanding of biochemistry to the diagnostic tool used today by the many hundreds of practitioners forming the patch testing societies and contact dermatitis groups leading the development in the field.

Moreover, I have witnessed how the practice of comprehensive baseline patch testing has increased as a result of not only necessity, but by an increase in dedication and awareness among the patch testing physicians.

In past years I saw many clinics screen patients with suspected ACD solely with a European Baseline Series or settle with the limited series found in a factory-made patch as the hapten selection required to pinpoint rare or improbable allergies was deemed overwhelming by many.

Today I am relieved to find that the development of comprehensive baseline series has not only been welcomed, but also incorporated in the everyday practice in many clinics. Especially in times like these when several culprit haptens behind the ACD created by the use of face masks are not found in slimmer Baseline Series.

Pinpointing rare allergies will still remain an arduous task that will require not only thorough investigation and perseverance but also luck occasionally. By the increased adoption of comprehensive baseline screening I am confident that the quality of the diagnosis of patients with Contact Allergies will improve significantly as more culprit haptens will be detected. This will have a positive impact on the quality of life for those patients that suffer from contact dermatitis both from occupational exposure and environmental exposure.

Sincerely yours,

Bo Niklasson
CEO and President
Chemotechnique MB Diagnostics AB

Table of Contents

President's message	1
Chemotechnique	4
Contact Allergy	6
Patch Test Products	8
• IQ Ultra™	10
• IQ Ultimate™	11
• Patch Test Accessories	12
• Spot Tests	13
• Topical Haptens.....	14
• Hapten Series	16
• International Baseline Series	17
• International Screening Series.....	18
Patch Test Instructions	21
Featured topics.....	24
Clinical information.....	26
FAQ	32
Composition of International Baseline Series	33
Composition of International Screening Series	59
List of Topical Haptens	83
Hapten Information.....	107
Catalogue amendments	216
• Catalogue amendments February 2022	220



Patch Test Products
authorized by the **ICDRG**
Distributed Worldwide



Production: Chemotechnique MB Diagnostics AB
Printing: Exakta 2021 Revised: November 2021
© 2021 Chemotechnique MB Diagnostics AB

Chemotechnique MB Diagnostics AB
Modemgatan 9 | SE-235 39 | Vellinge
Sweden | Tel +46 40 466 077
www.chemotechnique.se

Chemotechnique



CHEMOTECHNIQUE
DIAGNOSTICS

Chemotechnique - The trusted name in Patch Testing



Chemotechnique MB Diagnostic AB (“Chemotechnique”) has provided Patch Test solutions since 1981 and is proudly recognized as the Trusted name in Patch Testing. Chemotechnique is a Sweden based company with global reach through world-wide distribution.

Research and Development



With emphasis on R&D and working in close cooperation with contact dermatitis research groups such as the International Contact Dermatitis Research Group (ICDRG), the European Environmental and Contact Dermatitis Research Group (EECDRG) and the North American Contact Dermatitis Group (NACDGG), Chemotechnique ensures an ideally composed product line-up.

Highest quality products



Chemotechnique offers a complete range of high quality Patch Test Products including Topical Haptens, Patch Test Units as well as Patch Test Accessories and Spot Tests. Our haptens are produced in Sweden under strict pharmaceutical control following the **GMP** quality management system audited by the Swedish Medical Products Agency. Certified by the **ISO 13485** and **ISO 9001** Quality Management systems the Chemotechnique high quality products and reliable service will aid you in the diagnosis of contact allergy in your patients.

Online resources



Visit the continually updated www.chemotechnique.se website to access the Chemotechnique online resources including an extensive **Hapten Database**, patch testing **Video Instructions**, **Patch test record forms**, **Patient information sheets** and much more. Create a free account today!

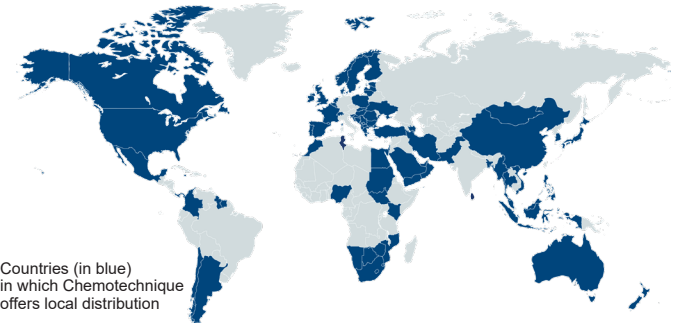

Countries (in blue)
in which Chemotechnique
offers local distribution



www.chemotechnique.se
for both desktop and mobile

Contact Allergy



Contact Allergy & Allergic Contact Dermatitis (ACD)



Contact Allergy is the result of specific immune responses caused by **antigens**. Unlike **allergens** (such as pollens and animal proteins) causing other forms of allergy, the culprits of Contact Allergies, **haptens**, are not antigens by themselves. Haptens (typically small, chemically reactive molecules with low molecular weight) need to penetrate the horny layer of the skin in order to conjugate to epidermal and dermal proteins forming “hapten-carrier complexes” with antigenic properties capable of causing **contact allergy**. Examples of widely recognized haptens include nickel, formaldehyde and other preservatives in cosmetics.

Contact allergy is the state of being sensitized to a hapten. Sensitization to a hapten occurs when the accumulated exposure to the hapten surpasses a certain threshold. This threshold is individual and varies greatly, some will develop an allergy the first time encountering the hapten while others withstand a life time of exposure without becoming sensitized. The median prevalence of contact allergy to at least one hapten is around 25% in the general population.

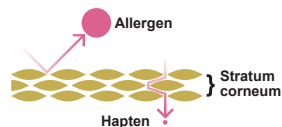

Allergic Contact Dermatitis (ACD) is a disease of the skin that can emerge in people that are exposed to specific haptens after having developed contact allergy to them. Once allergic, the subject might respond with skin inflammation (redness, flaking skin or blisters) whenever exposed. Individuals handling haptens as part of their

profession run a higher risk of developing **ACD**. ACD accounts for 20% of all reported work related skin diseases. Occupational fields with high occurrences of ACD include (but are not limited to) hairdressing, construction work, cleaning and health care. Chronic once developed, and with no known cure, contact allergy is of major distress for those affected.

Diagnosis



While contact allergy cannot be treated it can be diagnosed; by **Patch Testing** and not by **Skin Allergy Testing** (such as skin prick testing - used for the diagnosis of, for instance, respiratory allergies). Knowing what hapten is causing the allergic reactions helps the patient stay clear of that specific hapten, avoiding **ACD** and thereby effectively improving the quality of life for the individual.

The indication for Patch Testing is to **test all patients in whom contact allergy is suspected or needs to be ruled out**, regardless of age or anatomical site of dermatitis.

Chemotechnique provides all tools required to perform patch tests the IQ way - the gold standard for diagnosing contact allergy.

In order to perform a diagnostic Patch Test, two crucial components are required; **Topical Haptens** and **Patch Test Units**.

Topical Haptens

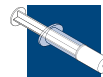

The hapten preparations used in patch testing should ideally be specifically developed for patch testing purposes.

The Topical Haptens manufactured by Chemotechnique are standardized and prepared by mixing high purity fine particle ground raw material with high purity grade white petrolatum using state of the art technology.

Patch Test Units



To ensure that the hapten remains in direct contact with the skin for the time required (48h) to create a standardized controlled reaction, a Patch Test Unit is needed. A Patch Test Unit is composed of sets of chambers mounted on an adhesive tape. The purpose of the patch test chambers is to provide a defined area in which the skin will be exposed to the haptens during the testing.

Patch Test Products

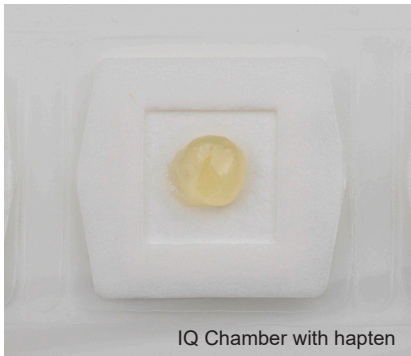

IQ Chamber with haptens



IQ Patch Test Chambers

The Inert Quadrate (IQ) chambers are the most technologically advanced patch test chambers ever developed.

The laminated tape/foam/filter paper construction results in a comfortable chamber providing a unique closed-cell and leak-free system which defines a test area.

The quadrate shape allows for easy differentiation between allergic and irritant reactions. This patented patch test chamber design is found in both IQ Ultra™ and IQ Ultimate™ Patch Test Units.

The integrated filter papers makes handling of loose filter papers unnecessary.

Adhesive chamber rim



The adhesive eliminates haptens leakage and enhances the adhesion of the test unit to the skin.

Integrated filter paper



The integrated filter paper facilitates easy handling of liquid haptens.

Foam frame for high comfort



The chambers are made of inert additive free soft polyethylene foam.

IQ Chamber:

Size:

Inside area: 64 mm²

Chamber volume: 32 µl

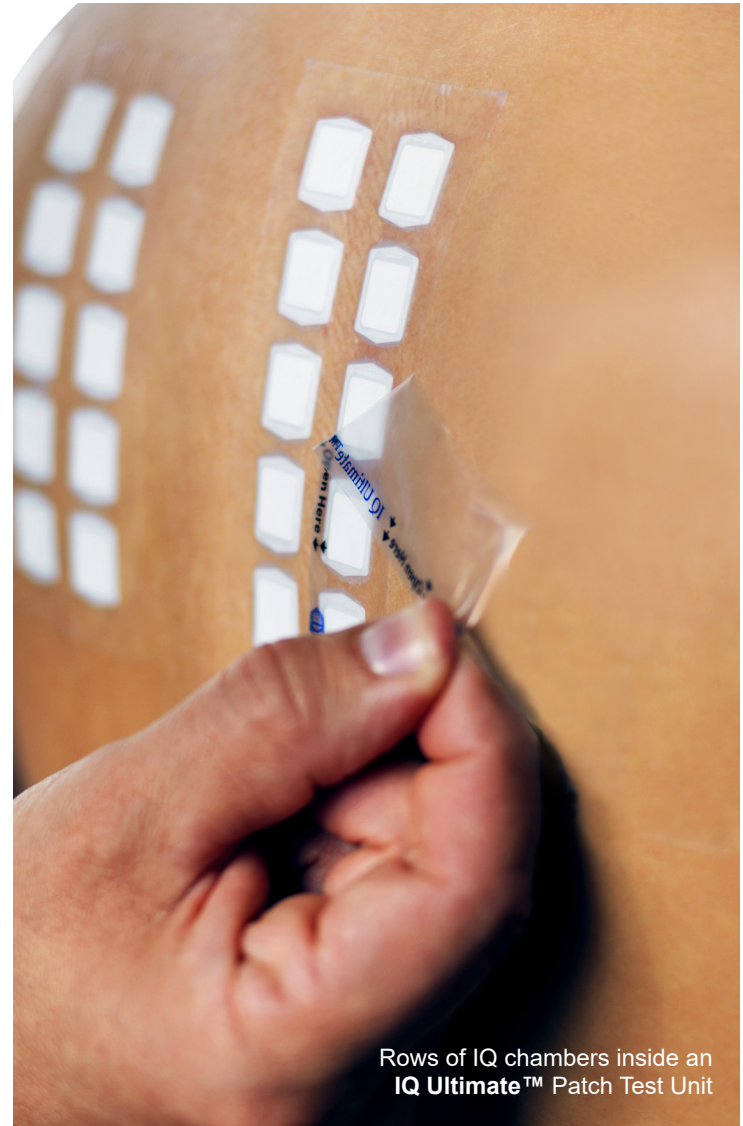

Rows of IQ chambers inside an IQ Ultimate™ Patch Test Unit

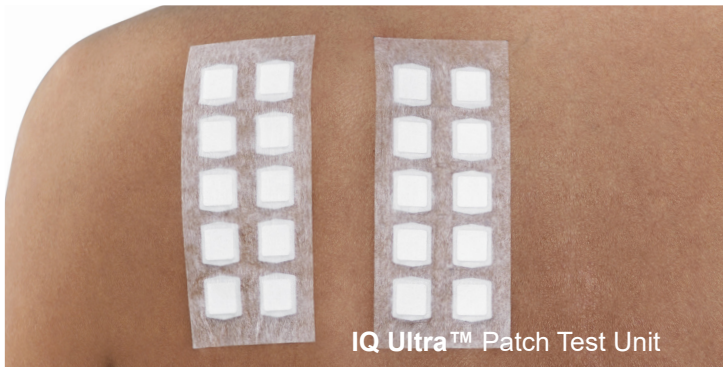

IQ Ultra™ (IQ-U)

Comfortable and chemically inert - **IQ Ultra™** is the reliable patch test choice. The **IQ Ultra™** is designed to take full advantage of the acclaimed IQ Chambers. The strong adhesive properties of the premium quality, hypoallergenic and latex free carrier tape eliminates the need for extra reinforcement for patients with normal skin. The **IQ Ultra™** Patch Test Units are most cost effective as filter papers and protective covers are not add-ons, but integrated into the design.

IQ Chambers



The **IQ Ultra™** Patch Test Unit is designed to take full advantage of the IQ Chambers.

With strong adhesion and compact size it is a versatile and reliable Patch Test Unit.

Closed-cell & Leak-free



The closed-cell chamber provides a defined test area for standardized testing as the concept of dose/area can be used.

Protective cover



Preloading increases staff efficiency as multiple tests can be prepared in advance.

By using the **Application Device**, loading of the test units is made efficient and time saving.

Aluminum free



No uncomfortable metal chambers that might react chemically to haptens ensures test reliability. Aluminum free means environmentally safe.



IQ Ultimate™ (IQ-UL)

Elastic, transparent and water resistant. In addition to the features shared with the **IQ Ultra™**, **IQ Ultimate™** has the above named added benefits as a result of the 25 micron thin carrier film. Allowing for both moderate showers and exercise - **IQ Ultimate™** is the ideal Patch Test Unit for the diagnosis of contact allergy in active patients.

Water resistant



The **IQ Ultimate™** carrier tape is water resistant allowing for moderate exercise

and showers during the patch test procedure.

Superior adhesion



IQ Ultimate™ is the perfect patch test choice in warm climate due to its superior

adhesion to the skin.

Highly elastic



The elasticity of the **IQ Ultimate™** carrier tape permits patients to maintain an active

lifestyle during the test period.

IQ Ultra™/IQ Ultimate™:

The box includes 100 Patch Test Units as well as a Reading Plate.

Patch Test Unit:

Size: 52 x 118 mm
Chambers/Unit: 10 pcs

Patch Test Accessories



The **Application Device (AP-P)** significantly facilitates preloading multiple **IQ Ultra™** or **IQ Ultimate™** Patch Test Units. This is convenient when preparing test series in advance, such as the **Baseline Series**, for a suitable number of patients.

Syringe Cap Organizer



The device is equipped with a feature that facilitates the detachment and attachment of the syringe caps without skin contact.

Fixates Patch Test Units



The design prevents the Patch Test Unit from sliding during application of the haptens.



The **Reading Plate for IQ Ultra™/ IQ Ultimate™ (RP-P)** facilitates reading and the interpretation of the skin reactions.

Easy Diagnosis

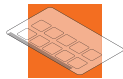

To facilitate visual diagnosis, reference pictures of allergic reactions are printed on the Reading Plate.

The images are categorized in accordance with the definition recommended by the **International Contact Dermatitis Research Group (ICDRG)**.



The **Chemo Skin Marker Medium™** is a long lasting skin marking tool specially suited for patch test site marking.

Distinct marking



The Chemo Skin Marker™ - Medium has a medium round (bullet) type tip for a distinct marking. The skin marker is non-toxic, non-irritating and non-tattooing.

Chemo Skin Markers™ - Medium (SMM-4)

Chemo Skin Markers™ - Medium are provided in boxed sets of 4 units

Spot Tests



Chemo Nickel Test™ (NT) and **Chemo Cobalt Test™ (CoT)** are one-component solutions that enable easy detection of free nickel or cobalt in metallic objects.



Contained in a re-sealable packaging, the test solutions are conveniently stored alongside provided swabs.

Rub & Compare



Rub a moistened cotton swab on the suspected metal object and compare the result with the reference color.

Chemo Spot Tests

Volume:

8 ml (50 tests+)

Reagents:

Nickel: Dimethylglyoxime

Cobalt: Nitroso-R salt

Topical Haptens



Chemotechnique offers the widest range of commercially available high quality Topical Haptens. The 555+ different preparations are available for purchase in sets of series or as individual preparations. The composition of the various Baseline Series, as well as the additional Screening Series, has been carefully selected based on the latest studies and in close co-operation with leading contact dermatitis societies.

Highest quality



The Topical Haptens are prepared using state of the art technology by grinding high purity raw materials down to extremely fine particle size. The ground particles are homogenized either with high purity grade white petrolatum or with the appropriate highest purity liquid vehicles.

Preloading



Non-volatile Topical Haptens may be preloaded onto **IQ Ultra™** or **IQ Ultimate™** Patch Test Units and stored for up to two weeks before test application if stored refrigerated, with sealed covers, and kept in air tight bags.

Hapten preparations that may not be preloaded are marked:

**DO NOT
PRELOAD**

Listed online



The composition of some series is not listed in this printed catalogue but only available for review online. These series are subject to irregular updates why consulting the **chemotechnique.se** for current composition is advised.

Affected series are marked with:



Topical Haptens:

Topical Haptens are delivered in either 5 ml syringes or in 8 ml dropper bottles and covers approx. 150 patients (~200 25µl doses).

Baseline Series



The haptens in a Baseline Series form the foundation for all routine patch testing. Chemotechnique has developed several regional and national Baseline Series in co-operation with local clinics and research groups. These tailored Baseline Series enable efficient routine Patch testing with maintained high relevance.

In addition to Baseline Series, a Screening Series may be added based on the occupation and everyday exposure of the patient. Chemotechnique provides a number of such Screening Series, all of which are listed on the next page.

International Baseline Series:

- European Baseline (S-1000)
- European Comprehensive Baseline (ECB-1000)
- International (Standard) Baseline (IS-1000)
- International Comprehensive Baseline (ICB-1000)
- Latin American Baseline (LA-1000)
- North American Baseline (NA-1000)
- North American Extended (NAE-65)
- North American Comprehensive (NAC-80)
- American Core Series (AC-1000)

National Baseline Series:

- Australian Baseline (ABS-1000)
- Belgian Baseline (BS-1000)
- British Baseline (GB-1000)
- Chinese Baseline (CB-1000)
- Finnish Baseline (FIN-1000)
- Hungarian Baseline (HU-1000)
- Indian Baseline (INS-1000)
- Italian Baseline (SIDAPA-1000)
- Korean Baseline (KOR-1000)
- New Zealand Baseline/Extended (NZBS/NZBSE-1000)
- Portuguese Baseline (PB-1000)
- Polish Baseline/Extended (PST/PSE-1000)
- Spanish Baseline (SB-1000)
- Swedish Baseline (SS-1000)

Tailored testing:

All Topical Haptens produced by Chemotechnique can be ordered separately, making customization of series possible. This is ideal when catering for patient specific exposure.

Screening Series



The Screening Series are used in combination with a Baseline Series to facilitate the screening of patients with occupational, or recreational, exposure to a defined set of haptens.

International Screening Series:

- Bakery (B-1000)
- Corticosteroid (CS-1000)
- Cosmetic (C-1000)
- Cutaneous Adverse Drug Reaction (CAD-1000)
- Dental Screening (DS-1000)
- Dental Materials - Patients (DMP-1000)
- Dental Materials - Staff (DMS-1000)
- Epoxy (E-1000)
- European Photopatch Baseline (EP-1000)
- European Photopatch Extended (EPE-1000)
- Fragrance (F-1000)
- Hairdressing (H-1000)
- Implant (IMP-1000)
- Isocyanate (I-1000)
- Leg Ulcer (LU-1000)
- Medicament (ME-1000)
- Metal (MET-1000)
- Metal Extended (METE-1000)
- (Meth) Acrylate - Adhesives, Dental, Printing & Other .. (MA-1000)
- (Meth) Acrylate - Artificial Nails (MN-1000)
- Oil & Cooling Fluid (O-1000)
- Plant (PL-1000)
- Plastic & Glue (PG-1000)
- Rubber Additives (R-1000)
- Shoe (SH-1000)
- Sunscreen (SU-1000)
- Textile Colors & Finish (TF-1000)

National Screening Series:

- Indian Footwear (INF-1000)
- Indian Cosmetic & Fragrance (INC-1000)
- North American Photopatch (NAP-1000)

Photopatch testing:

Photopatch Series test for reactions to irradiated and non-irradiated photohaptens. The test method when testing photopatch series differs from regular patch testing. Please visit www.photopatch.eu for the ESCD approved methodology.

International Baseline Series

European (Comprehensive) Baseline / (S-1000, ECB-1000) p. 33 p.35



The European Baseline (EBS) was the first defined Baseline Series and forms the foundation for many other Baseline Series. The Comprehensive Series includes additional haptens for routine screening as recommended by the EBS branch of the European Society of Contact Dermatitis (**ESCD**).

International Baseline (IS-1000) p. 37



This Baseline Series is a selection of haptens based on the studies performed by the International Contact Dermatitis Research Group (**ICDRG**).

International Comprehensive Baseline (ICB-1000) p. 40



This extensive Baseline Series is ideal for physicians preferring comprehensive routine screening. The selection of haptens is based on the studies performed by the North American Contact Dermatitis Group (**NACDG**).

Latin American Baseline (LA-1000) p. 43



This Baseline Series is a selection of haptens based on the studies performed by the Colegio Ibero-Latinoamericano de Dermatología (**CILAD**).

North American Baseline Series (NA-1000, NAE-65, NAC-80) p. 45/ p. 48/ p. 51



These Baseline Series are selections of haptens based on studies performed by the North American Contact Dermatitis Group (**NACDG**). The Series contains 50, 65 and 80 haptens respectively, providing suitable Baseline Series for any clinic.

American Core Series (AC-1000) p.55



This Baseline Series is a selection of haptens recommended by the American Contact Dermatitis Society (**ACDS**).

International Screening Series

Bakery (B-1000) p. 59



This series is a selection of haptens (primarily preservatives and substances valued for their fragrance and taste) included in foods and pastries.

Corticosteroid (CS-1000) p. 59



This series is a selection of haptens found in topical pharmaceutical products such as corticosteroid creams and ointments.

Cosmetic (C-1000) p. 60



This series is a selection of haptens used for fragrance, preservation, sun protection and formulation of cosmetics and beauty products.

Cutaneous Adverse Drug Reaction (CAD-1000) p. 62



This series is a selection of haptens present in pharmaceutical products such as antibiotics, NSAID's and painkillers. These pharmaceutical products may cause systemic dermatitis.

Dental Screening (DS-1000) p. 63



This series is a selection of haptens, primarily metals and plastics, which **both patients and professionals** are exposed to in dental care.

Dental Materials - Patients (DMP-1000) p. 64



This series is a selection of haptens that primarily dental care **patients** are exposed to. These haptens include plastics, fragrances and materials used for mending teeth.

Dental Materials - Staff (DMS-1000) p. 65



This series is a selection of haptens that primarily dental care **professionals** are exposed to. These haptens include plastics, fragrances and materials used for mending teeth.

Epoxy (E-1000) p. 65



This series is a selection of haptens (primarily stabilizers, additives, resins and epoxies) professionals working with epoxy pastes and glues are exposed to.

European Photopatch Baseline (EP-1000) p. 65



This series is a selection of haptens (UV-blockers, additives and pharmaceutical compounds) present in skincare products protecting against the sun.

European Photopatch Extended (EPE-1000) p. 66



This series is an extended selection of haptens (UV-blockers, additives and pharmaceutical compounds) present in skincare products protecting against the sun.

Fragrance (F-1000) p. 67



This series is a selection of haptens (fragrances) found in perfumes, scented products, cleaning products and beauty products among others.

Hairdressing (H-1000) p. 68



This series is a selection of haptens that hairdressing professionals are exposed to. These haptens include coloring agents, stabilizers, metals and preservatives.

Implant (IMP-1000) p. 70



This series contains haptens which are included in metal implants, bone cement and antibiotics which are all known to cause contact allergy.

Isocyanate (I-1000) p. 70



This series is a selection of haptens (primarily chemicals that are used as stabilizers or additives in plastics) that professionals working with isocyanates are exposed to.

Leg Ulcer (LU-1000) p. 71



This series is a selection of haptens (substances used for their medical, preservative or formulative properties) which patients can be exposed to when being treated for leg ulcers.

Medicament (ME-1000) p. 72



This series is a selection of haptens that healthcare professionals are exposed to when medicating antibiotics and topical pharmaceutical products.

Metal (MET-1000) p. 73



This series is a selection of haptens (metals present in everyday objects such as jewelry, coins and tools) commonly causing contact allergy.

Metal Extended (METE-1000) p. 74



This series is an extension to the Metal Series, providing alternate concentrations, vehicles and markers to metals found in the Metal Series.

Hapten Series

(Meth) Acrylate - Adhesives, Dental, Printing & Other (MA-1000) p. 74



This series is a selection of haptens that professionals working with acrylates in adhesives (primarily in the dental field) are exposed to.

(Meth) Acrylate - Nails Artificial Series (MN-1000) p. 75



This series is a selection of haptens (plastics and acrylates) found in artificial nails and products relating to the adhesion of artificial nails.

Oil & Cooling Fluid (O-1000) p. 76



This series is a selection of haptens (primarily stabilizers and preservatives) that professionals working with mechanical fluids are exposed to.

Plant (PL-1000) p. 77



This series is a selection of haptens (plant extracts) that outside their natural environment commonly are found in "natural / organic" beauty products.

Plastic & Glue (PG-1000) p. 78



This series is a selection of haptens (stabilizers, plastics, phthalates, preservatives and bactericides) that professionals working with plastics are exposed to.

Rubber Additive (R-1000) p. 78



This series is a selection of haptens (stabilizers, antioxidants, preservatives and bactericides) that professionals working with rubber are exposed to.

Shoe (SH-1000) p. 79



This series is a selection of haptens (tanning materials, coloring agents and preservatives/bactericides) that are found in shoes and in the shoe manufacturing industry.

Sunscreen (SU-1000) p. 80



This series is a selection of haptens (UV-blockers) found in skincare products that protect against the sun.

Textile Colors & Finish (TF-1000) p. 81



This series is a selection of haptens (primarily coloring agents and bactericides) found in textiles and clothes.

Patch Test Instructions



Preloading an IQ Ultimate™ Patch Test Unit using the Application Device



Application of IQ Ultimate™ Patch Test Unit



Removing the topliner of the IQ Ultimate™

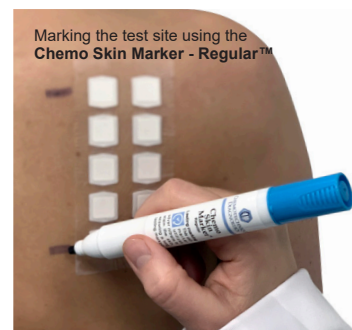

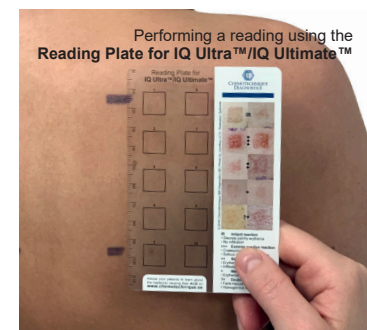

Marking the test site using the Chemo Skin Marker - Regular™

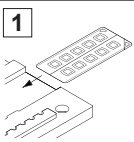
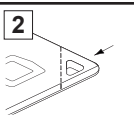
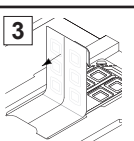
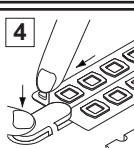
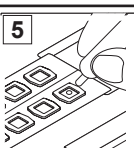
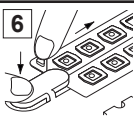

Performing a reading using the Reading Plate for IQ Ultra™/IQ Ultimate™

Patch Test Instructions

	Remove Patch Test Haptens from refrigeration.
	Insert IQ Ultimate™ or IQ Ultra™ Patch Test Unit into the Application Device .
	Break the perforation of a preferred corner by folding the corner downwards and upwards.
	Grip the tape by the detached corner and pull back gently until all chambers are revealed. Do not completely remove the tape from the protective cover.
	Depress the clip on the Application Device and slide the tape underneath - release the clip
	Apply hapten in each patch test chamber starting with the 1 st hapten of the series in the corresponding chamber. The recommended dose is 25 µl* .
	Depress the clip and carefully detach the Patch Test Unit. Remove the Patch Test Unit from the Application Device .
	Put haptens (and Patch Test Units if preloading) back in fridge. ! Preloaded Patch Test Units can be stored for < 2 weeks if stored in air tight bags**

* 25 µl equals approximately to a 5 mm string of petrolatum or a single drop of liquid.
** Volatile haptens may never be preloaded.

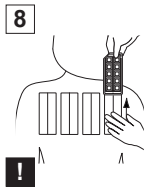
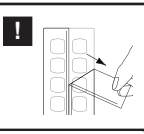
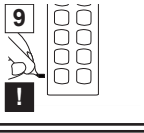
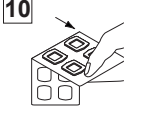
	Position the Patch Test Unit by holding it by its protective cover and apply the tape onto the patient. Remove the plastic corner. Press your palm on the tape for 5 seconds to enhance adhesion. ! Wipe the test site with ethanol before application to ensure good adhesion.
	IQ Ultimate™ only: When all test units have been applied, remove the top-liners with a gentle diagonal motion.
	Mark the 1 st and the 5 th chamber using a Chemo Skin Marker™ . ! Register the sites location in a Patch test record form.***
	After 48 hours: Remove the Patch Test Units with a gentle diagonal motion to minimize patient discomfort.



Applying an **IQ Ultra™** Patch Test Unit

*** Patch Test record forms are available at www.chemotechnique.se

Featured topics



Introducing the Implant Series

Chemotechnique proudly presents our latest Screening Series addition - the Implant Series (IMP-1000).

The Implant Series contains chemicals and substances which are included in implants. The implant Series is based on comprehensive scientific research and recommendations from various research groups and consists of haptens found in metal implants, bone cement and antibiotics, which are all known to cause contact allergy.

See the series composition on p.69



Meet the Patch Tester

The Patch Tester, our quarterly e-magazine highlighting the most recent findings and advancements in the field of patch testing, has turned two years old!

Our motivation in creating the Patch Tester was to provide an outlet not only for the patch testing MD, but for everyone with an interest in patch testing; doctors, nurses and patients alike with the goal of presenting the latest hot topics in patch testing in an accessible format.

The Patch Tester is available free of charge and can be read at www.patchtester.com.

Something on your mind?

If you would like to contribute to the Patch Tester, please contact david.niklasson@chemotechnique.se.

Clinical information

Patch Testing

Patch testing involves a number of scheduled patient appointments within a one-week time-frame. After the test application on Day 0, two or three appointments are needed for readings.

Patch test mode of action

For topical use only. The patch test procedure is an epicutaneous diagnostic provocation test using standardized haptens (“Topical Haptens”). Haptens are typically small, chemically reactive molecules with low molecular weight that, when bound to skin protein, are able to elicit an immune response. Patch testing is performed by applying haptens into small chambers mounted on tape (“Patch Test Units”) and placed onto the patient’s skin. In sensitized individuals this immune response results in an allergic contact eczema confined to the application area of the chamber on the patient’s skin (a positive patch test reaction).

Indications

Patch Testing is the standard procedure for aiding the diagnosis of Contact Allergy when Allergic Contact Dermatitis (ACD) resulting from type IV hypersensitivity is suspected. **The indication is to test all patients in whom contact allergy is suspected** or needs to be ruled out, regardless of age or anatomical site of dermatitis.

Indications also include conditions that may mimic a contact allergic reaction and needs to be ruled out, such as:

- Erythema multiforme-like
- Lichen planus-like
- Psoriasis of the hands
- Granulomatous or lymphomatoid reactions
- Worsening of pre-existing dermatitis (stasis, atopic or seborrhoeic dermatitis)
- Mucous membrane reactions (conjunctivitis, stomatitis, vulvitis)
- Discoid (nummular) eczema
- Implant reactions
- Certain drug eruptions

Series composition

Chemotechnique MB Diagnostics AB, in presenting the various Screening Series in this Reference Manual, does its best to include compounds associated with each field based on current technical, occupational and scientific information, however, each Series should not be considered as all inclusive with compounds associated with each field.

Contraindications



Do not apply Patch Test Hapten (hereinafter referred to as “haptens”) on patients undergoing cortisone treatment or taking other medication altering the immune system such as immunosuppressive treatment.

Do not apply hapten on a patient with a known history of severe allergic reaction (local or systemic) to the hapten in question, on patients with severe or generalized active dermatitis or on patients with excited skin syndrome.

Do not apply hapten on unhealthy or injured skin or on a test area recently exposed to ultraviolet radiation (UV).

Do not apply hapten on patients with dermatitis on the upper back area aimed for the application of patch tests or on test sites recently treated with topical corticosteroids; wait at least 1 week after treatment.

Pregnancy and lactation may be a conditional contraindication as there are no data on the safety of the test for the mother and child.

Precautions

Haptens:



• **Do** advise patient to protect the Patch Test Units from sunlight (UV radiation) during ongoing patch testing.

• **Do consider** priming each hapten contained in a syringe. Priming is done by discarding a single dose from the tip of the syringe and thereby possible evaporation/degradation of the active compound is avoided. If applications are done in a sequence, there is no need to prime before each new application.

• **Do** apply a recommended dose of 25 µl of hapten into the **IQ Ultra™ / IQ Ultimate™** patch test chambers (25 µl equals to approximately a 5 mm string of petrolatum or a single drop of liquid).

• **Do** remember to put on the protective caps after each application.



• **Do not** switch protective caps between syringes. This may lead to contamination of the hapten applied onto the patch test chamber.

Clinical information

Volatile Hapten preparations (Fragrances and Acrylates) only:



- **Do not** preload volatile haptens. Apply hapten preparation into patch test chamber directly before application onto patient.

- **Volatile haptens contained in syringes must be primed before application.**

IQ Ultra™ / IQ Ultimate™:



- Wiping the test site with ethanol before application is important will improve adhesion of the Patch Test Unit on patients with oily skin. For patients with very dry or oily skin, additional reinforcing tape might be required. Consider clipping the hair on the test site before patch test application for hairy patients.



- Exercise must be avoided during the patch test period. Additionally, water submersion and showers must be avoided if using the **IQ Ultra™**.

Patch test placement:

- Use the upper part of the patients back if possible. Avoid applying Patch Test Units to the midline and the scapula. Do not put any Patch Test Units under a brassiere shoulder band which can cause dislocation of the test units.

Reactions

Normal reactions:

- In sensitized patients, exposure to haptens during the patch testing procedure will normally result in a miniature eczema (normal patch test reaction).

- In addition to the visual imprints on the skin from each chamber, a slight erythema from the frames should be visible as a sign of good occlusion. The erythema generally subsides within 30 minutes after removal of the test units. The erythema may however prevail for up to 24h or more for patients with sensitive skin.

- Itching and burning may occur at the site of application of the Patch Test Units; it can either be caused by a positive patch test reaction or due to tape irritation.

Adverse reactions:

- A strong positive reaction may result in a flare-up of an existing, or sometimes a previous, dermatitis. Such flare-up reactions usually indicate that the responsible hapten is or has been, respectively, the cause of the dermatitis. In rare occasions, acute allergic reactions including anaphylaxis may occur. Sensitization by patch testing is a rare but potential complication of patch testing. It is regarded as a positive patch test reaction generally 2 weeks after an initially negative response at the same patch test site. Rarely localized transient hyperpigmentation or hypopigmentation may occur.

- A positive patch test reaction can rarely persist for up to several weeks.

- **Instruct patients to report any side effects.**

Warnings

Topical Haptens:

- **For topical use only.** Avoid contact with eyes. Use only on intact skin.

- **IF SWALLOWED:** Contact a Poison Control Center right away.

- **ACUTE REACTIONS:** Patients should be advised to seek immediate medical attention should they experience symptoms of acute allergic reaction after patch test application (trouble breathing or wheezing, a swollen tongue or throat, dizziness, fainting or altered pulse).

Patch test considerations:

- Patch testing for allergic contact dermatitis is a process involving 3 to 4 scheduled patient appointments within a one-week time-frame.

- The main reading should be performed within 48h of the removal of the Patch Test Units. A delayed response reading should be performed a full week after the initial test application for haptens that may show delayed reactions.

The reading criteria for morphologically positive patch test reactions defined by the **ICDRG** is widely acknowledged and used as a reference when diagnosing contact allergic reactions. The reading criteria are visualized on the **Reading Plate for IQ Ultra™/IQ Ultimate™**.

Clinical information

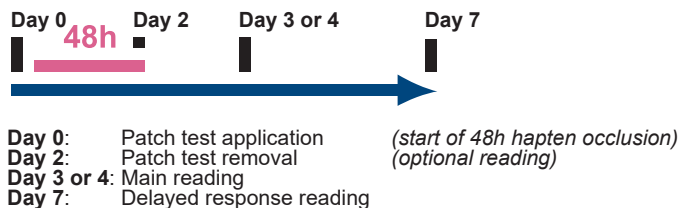

Contents

Topical Haptens:

Topical Haptens are delivered as one or more types of hapten preparations contained in one of two different delivering devices.

Topical Haptens are either contained in:

1. Hapten Dispensing Devices (“HDD”) consisting of one (1) HDD syringe body, one (1) HDD plunger and one (1) HDD protective cap.
2. Dropper bottles consisting of one (1) bottle body, one (1) eye dropper and one (1) protective screw cap.

IQ Ultra™ / IQ Ultimate™:

Patch Test Units are delivered in sets of hundreds (100) and consist of ten (10) patch test chambers mounted on adhesive backing tape protected by a protective plastic cover.

Storage

Topical Haptens:



Haptens must be stored protected from direct sunlight in a dry place refrigerated at 2-8°C. In rare occasions haptens (for instance P-038 and D-023B) must be stored frozen at ≤-18°C. Failure to store haptens as advised may affect the accuracy of the test results.

Please note that only haptens that are clearly marked may be stored at sub-zero temperatures.

IQ Ultra™ / IQ Ultimate™:

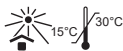

Patch Test Units must be stored dry at room temperature, protected from direct sunlight.

Expiry

Topical Haptens:

The expiry date is printed on the label of the hapten and use beyond this date is not recommended to ensure a valid performance.

IQ Ultra™ / IQ Ultimate™:

The expiry date of the Patch Test Units is printed on the box.

IQ Ultra™ and **IQ Ultimate™** Patch Test Units are single use products and may not be re-used.

Disposal

Topical Haptens:

Emptied and cleaned Patch Test Hapten containers may be regarded as combustible waste and recycled following national regulations.

IQ Ultra™ / IQ Ultimate™:

Used patches should be folded with the sticky side inwards and disposed of following national regulations.

Reading

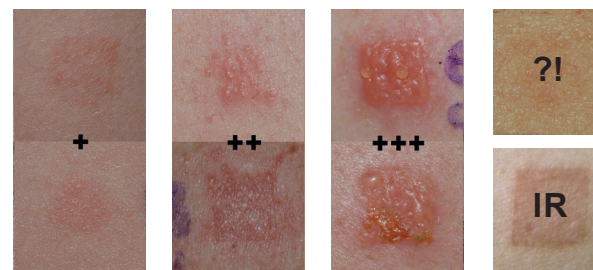

- IR Irritant reaction**
 • Discrete patchy erythema without infiltration
- +++ Extreme positive reaction**
 • Coalescing vesicles • Bullous or ulcerative reaction
- ++ Strong positive reaction**
 • Erythema • Infiltration • Papules • Discrete vesicles
- + Weak positive reaction**
 • Erythema • Infiltration • Papules
- ?+ Doubtful reaction**
 • Faint macular • No infiltration • Homogenous erythema

How much does a syringe/bottle contain?

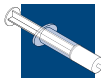

A syringe contains 5 ml of haptens preparation and a bottle contains 8 ml.

How many patients can be tested per syringe/bottle?

Approximately 150 patients/syringe and bottle.

Which volume should I dispense onto each patch test chamber?



The recommended dose is 25 µl. When applying haptens in petrolatum, dispense a 5 mm string into the IQ Patch Test Chamber (this corresponds to approximately 25 µl or 20 mg). For liquid haptens, the same amount (20-25 µl) is

produced by applying a single drop. Using a micropipette is however preferred.

Why are some haptens names written in CAPITAL letters?

Haptens names written in CAPITAL letters indicate that they are **INCI*** names. The use of INCI names facilitates detection of haptens in cosmetic products.

For how long time can I store a preloaded Patch Test Unit?



Non-volatile haptens can be preloaded for up to two weeks. Preloaded Patch Tests Units must be stored refrigerated in air tight bags. Volatile substances (acrylates and fragrances) and liquid haptens can not be preloaded.

Is there any way to improve adhesion of the Patch Test Units?



The Chemotechnique Patch Test Units have excellent adhesive properties if applied correctly.

Make sure to always put pressure on the applied test unit with the palm of your hand for at least

5 seconds. The heat and pressure will ensure good adhesion.

How long is the shelf life of the haptens?



The shelf life of a haptens depend on its composition. The shelf life is generally between **12-30 months** for petrolatum based haptens, and **6-12 months** for haptens based on aqua or ethanol.

The expiration date is clearly marked on the label of each haptens.

* INCI: International Nomenclature of Cosmetic Ingredients

Composition of International Baseline Series

DO NOT PRELOAD Volatile haptens, not recommended for preloading

¹ Also present in European Baseline Series

² Emulsifier: SORBITAN SESQUIOLEATE 5%

³ Emulsifier: SORBITAN SESQUIOLEATE 1%

⁴ Emulsifier: SORBITAN SESQUIOLEATE 2%

⁵ Contains DECYL GLUCOSIDE

⁶ Present in national series. Visit www.chemotechnique.se for further information.

^{EC} Directive 2003/15/EC relating to cosmetic products

European Baseline Series

S-1000

1.	Potassium dichromate	0.5	pet	P-014A
2.	p-PHENYLENEDIAMINE (PPD)	1.0	pet	P-006
3.	Thiuram mix	1.0	pet	Mx-01
	-Dipentamethylenethiuram disulfide (D-019)	0.25		
	-Tetraethylthiuram disulfide (TETD) (T-002)	0.25		
	-Tetramethylthiuram disulfide (TMTD) (T-005)	0.25		
	-Tetramethylthiuram monosulfide (TMTM) (T-006)	0.25		
4.	Neomycin sulfate	20.0	pet	N-001
5.	Cobalt(II)chloride hexahydrate	1.0	pet	C-017A
6.	Caine mix III	10.0	pet	Mx-19
	-Benzocaine (B-004)	5.0		
	-Dibucaine hydrochloride (D-005)	2.5		
	-Tetracaine hydrochloride (T-025)	2.5		
7.	Nickel(II)sulfate hexahydrate	5.0	pet	N-002A
8.	2-Hydroxyethyl methacrylate DO NOT PRELOAD	2.0	pet	H-010
9.	COLOPHONIUM	20.0	pet	C-020
10.	Paraben mix	16.0	pet	Mx-03C
	-BUTYLPARABEN (B-020)	4.0		
	-ETHYLPARABEN (E-010)	4.0		
	-METHYLPARABEN (M-012)	4.0		
	-PROPYLPARABEN (P-020)	4.0		
11.	N-Isopropyl-N-phenyl-4-phenylenediamine (IPPD)	0.1	pet	I-004
12.	LANOLIN ALCOHOL	30.0	pet	W-001
13.	Mercapto mix	2.0	pet	Mx-05A
	-N-Cyclohexyl-2-benzothiazolylsulfenamide 0.5 (C-023)			

Compound	Conc. Veh. %(w/w)	Art. No.
-Dibenzothiazyl disulfide (MBTS) (D-003)	0.5	
-2-Mercaptobenzothiazole (MBT) (M-003)	0.5	
-2-(4-Morpholinylmercapto)benzothiazol (MOR) (M-016)	0.5	
14. Epoxy resin, Bisphenol A	1.0 pet	E-002
15. Peru balsam ² <small>DO NOT PRELOAD</small>	25.0 pet	B-001
16. 4-tert-Butylphenolformaldehyde resin (PTBP)	1.0 pet	B-024
17. 2-Mercaptobenzothiazole (MBT)	2.0 pet	M-003A
18. FORMALDEHYDE <small>DO NOT PRELOAD</small>	2.0 aq	F-002B
19. Fragrance mix I ² <small>DO NOT PRELOAD</small>	8.0 pet	Mx-07
-AMYL CINNAMAL (A-014)	1.0	
-CINNAMYL ALCOHOL (C-013) <small>DO NOT PRELOAD</small>	1.0	
-CINNAMAL (C-014) <small>DO NOT PRELOAD</small>	1.0	
-EUGENOL (E-016) <small>DO NOT PRELOAD</small>	1.0	
-GERANIOL (G-001) <small>DO NOT PRELOAD</small>	1.0	
-HYDROXYCITRONELLAL (H-008)	1.0	
-ISOEUGENOL (I-002) <small>DO NOT PRELOAD</small>	1.0	
-Oakmoss absolute (O-001) <small>DO NOT PRELOAD</small>	1.0	
20. Sesquiterpene lactone mix	0.1 pet	Mx-18
-Alantolactone (A-003)	0.033	
-Costunolide (C-039)	0.033	
-Dehydrocostus lactone (D-056)	0.033	
21. QUATERNIUM-15	1.0 pet	C-007A
22. Propolis	10.0 pet	P-022
23. METHYLISOTHIAZOLINONE + METHYLCHLOROISOTHIAZOLINONE <small>DO NOT PRELOAD</small>	0.02 aq	C-009B
24. Budesonide	0.01 pet	B-033B
25. Tixocortol-21-pivalate	0.1 pet	T-031B
26. METHYLDIBROMO GLUTARONITRILE	0.5 pet	D-049E
27. Fragrance mix II <small>DO NOT PRELOAD</small>	14.0 pet	Mx-25
-Hexyl cinnamic aldehyde (H-025)	5.0	
-COUMARIN (C-038)	2.5	
-FARNESOL (F-004)	2.5	
-HYDROXYISOHEXYL 3-CYCLOHEXENE CARBOXALDEHYDE (L-003)	2.5	
-CITRAL (C-036)	1.0	
-CITRONELLOL (C-037) <small>DO NOT PRELOAD</small>	0.5	
28. HYDROXYISOHEXYL 3-CYCLOHEXENE CARBOXALDEHYDE	5.0 pet	L-003
29. METHYLISOTHIAZOLINONE <small>DO NOT PRELOAD</small>	0.2 aq	M-035B
30. Textile dye mix	6.6 pet	Mx-30

Compound	Conc. Veh. %(w/w)	Art. No.
-Dipperse Blue 35 (D-027)	1.0	
-Dipperse Orange 1 (D-031)	1.0	
-DISPERSE ORANGE 3 (D-032)	1.0	
-Disperse Red 1 (D-034)	1.0	
-DISPERSE RED 17 (D-035)	1.0	
-Disperse Yellow 3 (D-036)	1.0	
-Disperse Blue 106 (D-040)	0.3	
-Disperse Blue 124 (D-041)	0.3	

Revised October 2018

European Comprehensive Baseline Series

ECB-1000

1. Potassium dichromate ¹	0.5 pet	P-014A
2. p-PHENYLENEDIAMINE (PPD) ¹	1.0 pet	P-006
3. Thiuram mix ¹	1.0 pet	Mx-01
-Dipentamethylenethiuram disulfide (D-019)	0.25	
-Tetraethylthiuram disulfide (TETD) (T-002)	0.25	
-Tetramethylthiuram disulfide (TMTD) (T-005)	0.25	
-Tetramethylthiuram monosulfide (TMTM) (T-006)	0.25	
4. Neomycin sulfate ¹	20.0 pet	N-001
5. Cobalt(II)chloride hexahydrate ¹	1.0 pet	C-017A
6. Caine mix III ¹	10.0 pet	Mx-19
-Benzocaine (B-004)	5.0	
-Dibucaine hydrochloride (D-005)	2.5	
-Tetracaine hydrochloride (T-025)	2.5	
7. Nickel(II)sulfate hexahydrate ¹	5.0 pet	N-002A
8. 2-Hydroxyethyl methacrylate ¹ <small>DO NOT PRELOAD</small>	2.0 pet	H-010
9. COLOPHONIUM ¹	20.0 pet	C-020
10. Paraben mix ¹	16.0 pet	Mx-03C
-BUTYLPARABEN (B-020)	4.0	
-ETHYLPARABEN (E-010)	4.0	
-METHYLPARABEN (M-012)	4.0	
-PROPYLPARABEN (P-020)	4.0	
11. N-Isopropyl-N-phenyl-4-phenylenediamine (IPPD) ¹	0.1 pet	I-004
12. LANOLIN ALCOHOL ¹	30.0 pet	W-001
13. Mercapto mix ¹	2.0 pet	Mx-05A
-N-Cyclohexyl-2-benzothiazolylsulfenamide (C-023)	0.5	
-Dibenzothiazyl disulfide (MBTS) (D-003)	0.5	

Compound	Conc. Veh. %(w/w)	Art. No.
-2-Mercaptobenzothiazole (MBT) (M-003)	0.5	
-2-(4-Morpholinylmercapto)benzothiazol (MOR) (M-016)	0.5	
14. Epoxy resin, Bisphenol A1	1.0 pet	E-002
15. Peru balsam ^{1,2} <small>DO NOT PRELOAD</small>	25.0 pet	B-001
16. 4-tert-Butylphenolformaldehyde resin(PTBP) ¹	1.0 pet	B-024
17. 2-Mercaptobenzothiazole (MBT) ¹	2.0 pet	M-003A
18. FORMALDEHYDE ¹ <small>DO NOT PRELOAD</small>	2.0 aq	F-002B
19. Fragrance mix I ^{1,2} <small>DO NOT PRELOAD</small>	8.0 pet	Mx-07
-AMYL CINNAMAL (A-014)	1.0	
-CINNAMYL ALCOHOL (C-013) <small>DO NOT PRELOAD</small>	1.0	
-CINNAMAL (C-014) <small>DO NOT PRELOAD</small>	1.0	
-EUGENOL (E-016) <small>DO NOT PRELOAD</small>	1.0	
-GERANIOL (G-001) <small>DO NOT PRELOAD</small>	1.0	
-HYDROXYCITRONELLAL (H-008)	1.0	
-ISOEUGENOL (I-002) <small>DO NOT PRELOAD</small>	1.0	
-Oakmoss absolute (O-001) <small>DO NOT PRELOAD</small>	1.0	
20. Sesquiterpene lactone mix ¹	0.1 pet	Mx-18
-Alantolactone (A-003)	0.033	
-Costunolide (C-039)	0.033	
-Dehydrocostus lactone (D-056)	0.033	
21. QUATERNIUM-15 ¹	1.0 pet	C-007A
22. Propolis ¹	10.0 pet	P-022
23. METHYLISOTHIAZOLINONE + METHYLCHLOROISOTHIAZOLINONE ¹ <small>DO NOT PRELOAD</small>	0.02 aq	C-009B
24. Budesonide ¹	0.01 pet	B-033B
25. Tixocortol-21-pivalate ¹	0.1 pet	T-031B
26. METHYLDIBROMO GLUTARONITRILE ¹	0.5 pet	D-049E
27. Fragrance mix II ¹ <small>DO NOT PRELOAD</small>	14.0 pet	Mx-25
-Hexyl cinnamic aldehyde (H-025)	5.0	
-COUMARIN (C-038)	2.5	
-FARNESOL (F-004)	2.5	
-HYDROXYISOHEXYL 3-CYCLOHEXENE CARBOXALDEHYDE (L-003)	2.5	
-CITRAL (C-036)	1.0	
-CITRONELLOL (C-037) <small>DO NOT PRELOAD</small>	0.5	
28. HYDROXYISOHEXYL 3-CYCLOHEXENE CARBOXALDEHYDE ¹	5.0 pet	L-003
29. METHYLISOTHIAZOLINONE ¹ <small>DO NOT PRELOAD</small>	0.2 aq	M-035B
30. Textile dye mix ¹	6.6 pet	Mx-30
-Dipperse Blue 35 (D-027)	1.0	

Compound	Conc. Veh. %(w/w)	Art. No.
-Dipperse Orange 1 (D-031)	1.0	
-DISPERSE ORANGE 3 (D-032)	1.0	
-Disperse Red 1 (D-034)	1.0	
-DISPERSE RED 17 (D-035)	1.0	
-Disperse Yellow 3 (D-036)	1.0	
-Disperse Blue 106 (D-040)	0.3	
-Disperse Blue 124 (D-041)	0.3	
31. SODIUM METABISULFITE	1.0 pet	S-011
32. 2-BROMO-2-NITROPROPANE-1,3-DIOL	0.5 pet	B-015B
33. DIAZOLIDINYL UREA	2.0 pet	D-044A
34. IMIDAZOLIDINYL UREA	2.0 pet	I-001A
35. Compositae mix II <small>DO NOT PRELOAD</small>	2.5 pet	Mx-29B
-Anthemis nobilis extract (C-029) <small>DO NOT PRELOAD</small>	0.6	
-Chamomilla recutita extract (C-051) <small>DO NOT PRELOAD</small>	0.6	
-Achillea millefolium extract (A-025) <small>DO NOT PRELOAD</small>	0.5	
-Tanacetum vulgare extract (T-033) <small>DO NOT PRELOAD</small>	0.5	
-Arnica montana extract (A-024) <small>DO NOT PRELOAD</small>	0.25	
-Parthenolide (P-029)	0.05	
36. Hydroperoxides of Linalool <small>DO NOT PRELOAD</small>	1.0 pet	H-031A
37. Hydroperoxides of Linalool <small>DO NOT PRELOAD</small>	0.5 pet	H-031B
38. Hydroperoxides of Limonene <small>DO NOT PRELOAD</small>	0.3 pet	H-032A
39. Hydroperoxides of Limonene <small>DO NOT PRELOAD</small>	0.2 pet	H-032B
40. BENZISOTHIAZOLINONE	0.1 pet	B-003B
41. 2-n-Octyl-4-isothiazolin-3-one <small>DO NOT PRELOAD</small>	0.1 pet	O-004
42. DECYL GLUCOSIDE ⁴ <small>DO NOT PRELOAD</small>	5.0 pet	D-065
43. LAURYL POLYGLUCOSE <small>DO NOT PRELOAD</small>	3.0 pet	L-004

Revised November 2018

International Standard Series IS-1000

1. Potassium dichromate ¹	0.5 pet	P-014A
2. Neomycin sulfate ¹	20.0 pet	N-001
3. Thiuram mix ¹	1.0 pet	Mx-01
-Dipentamethylenethiuram disulfide (D-019)	0.25	
-Tetraethylthiuram disulfide (TETD) (T-002)	0.25	
-Tetramethylthiuram disulfide (TMTD) (T-005)	0.25	
-Tetramethylthiuram monosulfide (TMTM) (T-006)	0.25	
4. p-PHENYLENEDIAMINE (PPD) ¹	1.0 pet	P-006
5. FORMALDEHYDE ¹ <small>DO NOT PRELOAD</small>	2.0 aq	F-002B
6. COLOPHONIUM ¹	20.0 pet	C-020

Compound	Conc. Veh. %(w/w)	Art. No.
7. Peru balsam ^{1,2} <small>DO NOT PRELOAD</small>	25.0 pet	B-001
8. LANOLIN ALCOHOL ¹	30.0 pet	W-001
9. Mercapto mix ¹	3.5 pet	Mx-05C
-N-Cyclohexyl-2-benzothiazolysulfenamide (C-023)	0.5	
-Dibenzothiazyl disulfide (MBTS) (D-003)	0.5	
-2-Mercaptobenzothiazole (MBT) (M-003)	2.0	
-2-(4-Morpholinylmercapto)benzothiazol (MOR) (M-016)	0.5	
10. Epoxy resin, Bisphenol A ¹	1.0 pet	E-002
11. 4-tert-Butylphenolformaldehyde resin (PTBP) ¹	1.0 pet	B-024
12. Fragrance mix ^{1,2} <small>DO NOT PRELOAD</small>	8.0 pet	Mx-07
-AMYL CINNAMAL (A-014)	1.0	
-CINNAMYL ALCOHOL (C-013) <small>DO NOT PRELOAD</small>	1.0	
-CINNAMAL (C-014) <small>DO NOT PRELOAD</small>	1.0	
-EUGENOL (E-016) <small>DO NOT PRELOAD</small>	1.0	
-GERANIOL (G-001) <small>DO NOT PRELOAD</small>	1.0	
-HYDROXYCITRONELLAL (H-008)	1.0	
-ISOEUGENOL (I-002) <small>DO NOT PRELOAD</small>	1.0	
-Oakmoss absolute (O-001) <small>DO NOT PRELOAD</small>	1.0	
13. Nickel(II)sulfate hexahydrate	2.5 pet	N-002B
14. Textile dye mix	6.6 pet	Mx-30
-Dipperse Blue 35 (D-027)	1.0	
-Dipperse Orange 1 (D-031)	1.0	
-DISPERSE ORANGE 3 (D-032)	1.0	
-Disperse Red 1 (D-034)	1.0	
-DISPERSE RED 17 (D-035)	1.0	
-Disperse Yellow 3 (D-036)	1.0	
-Disperse Blue 106 (D-040)	0.3	
-Disperse Blue 124 (D-041)	0.3	
15. Budesonide ¹	0.01 pet	B-033B
16. QUATERNIUM-15	2.0 pet	C-007B
17. METHYLISOTHIAZOLINONE + METHYLCHLORO-ISOTHIAZOLINONE <small>DO NOT PRELOAD</small>	0.215 aq	C-009E
18. IMIDAZOLIDINYL UREA <small>DO NOT PRELOAD</small>	2.0 pet	I-001A
19. Tixocortol-21-pivalate ¹	0.1 pet	T-031B
20. METHYLDIBROMO GLUTARONITRILE	0.3 pet	D-049A
21. Carba mix	3.0 pet	Mx-06
-1,3-Diphenylguanidine (D-022)	1.0	
-ZINC DIBUTYLDITHIOCARBAMATE (ZBC) (Z-002)	1.0	

Compound	Conc. Veh. %(w/w)	Art. No.
-Zinc diethyldithiocarbamate (ZDC) (Z-003)	1.0	
22. Cobalt(II)chloride hexahydrate ¹	1.0 pet	C-017A
23. Compositae mix II <small>DO NOT PRELOAD</small>	5.0 pet	Mx-29A
-Anthemis nobilis extract (C-029) <small>DO NOT PRELOAD</small>	1.2	
-Chamomilla recutita extract (C-051) <small>DO NOT PRELOAD</small>	1.2	
-Achillea millefolium extract (A-025) <small>DO NOT PRELOAD</small>	1.0	
-Tanacetum vulgare extract (T-033) <small>DO NOT PRELOAD</small>	1.0	
-Arnica montana extract (A-024) <small>DO NOT PRELOAD</small>	0.5	
-Parthenolide (P-029)	0.1	
24. DIAZOLIDINYL UREA	2.0 pet	D-044A
25. Fragrance mix II ¹ <small>DO NOT PRELOAD</small>	14.0 pet	Mx-25
-Hexyl cinnamic aldehyde (H-025)	5.0	
-COUMARIN (C-038)	2.5	
-FARNESOL (F-004)	2.5	
-HYDROXYISOHEXYL 3-CYCLOHEXENE CARBOXALDEHYDE (L-003)	2.5	
-CITRAL (C-036)	1.0	
-CITRONELLOL (C-037) <small>DO NOT PRELOAD</small>	0.5	
26. Phenol formaldehyde resin (PFR2) <small>DO NOT PRELOAD</small>	1.0 pet	P-005
27. HYDROXYISOHEXYL 3-CYCLOHEXENE CARBOXALDEHYDE ¹	5.0 pet	L-003
28. N-Isopropyl-N-phenyl-4-phenylenediamine (IPPD) ¹	0.1 pet	I-004
29. Paraben mix ¹	16.0 pet	Mx-03C
-BUTYLPARABEN (B-020)	4.0	
-ETHYLPARABEN (E-010)	4.0	
-METHYLPARABEN (M-012)	4.0	
-PROPYLPARABEN (P-020)	4.0	
30. Sesquiterpene lactone mix ¹	0.1 pet	Mx-18
-Alantolactone (A-003)	0.033	
-Costunolide (C-039)	0.033	
-Dehydrocostus lactone (D-056)	0.033	

Revised January 2021

Compound **Conc. Veh.** **Art. No.**
%(w/w)

**International Comprehensive
 Baseline Series** **ICB-1000**

1.	Benzocaine	5.0	pet	B-004
2.	2-Mercaptobenzothiazole (MBT)	1.0	pet	M-003B
3.	COLOPHONIUM ¹	20.0	pet	C-020
4.	p-PHENYLENEDIAMINE (PPD) ¹	1.0	pet	P-006
5.	IMIDAZOLIDINYL UREA	2.0	pet	I-001A
6.	CINNAMAL <small>DO NOT PRELOAD</small>	1.0	pet	C-014
7.	Amerchol L-101	50.0	pet	A-004
8.	Carba mix	3.0	pet	Mx-06
	-1,3-Diphenylguanidine (D-022)	1.0		
	-ZINC DIBUTYLDITHIOCARBAMATE (ZBC) (Z-002)	1.0		
	-Zinc diethyldithiocarbamate (ZDC) (Z-003)	1.0		
9.	Neomycin sulfate ¹	20.0	pet	N-001
10.	Thiuram mix ¹	1.0	pet	Mx-01
	-Dipentamethylenethiuram disulfide (D-019)	0.25		
	-Tetraethylthiuram disulfide (TETD) (T-002)	0.25		
	-Tetramethylthiuram disulfide (TMTD) (T-005)	0.25		
	-Tetramethylthiuram monosulfide (TMTM) (T-006)	0.25		
11.	Clobetasol-17-propionate	1.0	pet	C-028
12.	Ethylenediamine dihydrochloride	1.0	pet	E-005
13.	Epoxy resin, Bisphenol A ¹	1.0	pet	E-002
14.	QUATERNIUM-15 ¹	2.0	pet	C-007B
15.	4-tert-Butylphenolformaldehyde resin (PTBP) ¹	1.0	pet	B-024
16.	Mercapto mix	1.0	pet	Mx-05B
	-N-Cyclohexyl-2-benzothiazolylsulfenamide (C-023)	0.25		
	-Dibenzothiazyl disulfide (MBTS) (D-003)	0.25		
	-2-Mercaptobenzothiazole (MBT) (M-003)	0.25		
	-2-(4-Morpholinylmercapto)benzothiazol (MOR) (M-016)	0.25		
17.	1,3-Diphenylguanidine	1.0	pet	D-022
18.	Potassium dichromate	0.25	pet	P-014B
19.	Peru balsam ^{1,2} <small>DO NOT PRELOAD</small>	25.0	pet	B-001
20.	Nickel(II)sulfate hexahydrate	2.5	pet	N-002B
21.	DIAZOLIDINYL UREA	1.0	pet	D-044C
22.	TOCOPHEROL <small>DO NOT PRELOAD</small>	100		T-036

Compound	Conc. Veh. % (w/w)	Art. No.
23.	Bacitracin	20.0 pet B-032B
24.	Mixed dialkyl thiourea	1.0 pet Mx-24
	-N,N'-Dibutylthiourea (D-038)	0.5
	-N,N'-Diethylthiourea (D-039)	0.5
25.	DISPERSE ORANGE 3	1.0 pet D-032
26.	Paraben mix	12.0 pet Mx-03A
	-BUTYLPARABEN (B-020)	3.0
	-ETHYLPARABEN (E-010)	3.0
	-METHYLPARABEN (M-012)	3.0
	-PROPYLPARABEN (P-020)	3.0
27.	METHYLDIBROMO GLUTARONITRILE ¹	0.5 pet D-049E
28.	Fragrance mix ^{1,2} <small>DO NOT PRELOAD</small>	8.0 pet Mx-07
	-AMYL CINNAMAL (A-014)	1.0
	-CINNAMYL ALCOHOL (C-013) <small>DO NOT PRELOAD</small>	1.0
	-CINNAMAL (C-014) <small>DO NOT PRELOAD</small>	1.0
	-EUGENOL (E-016) <small>DO NOT PRELOAD</small>	1.0
	-GERANIOL (G-001) <small>DO NOT PRELOAD</small>	1.0
	-HYDROXYCITRONELLAL (H-008)	1.0
	-ISOEUGENOL (I-002) <small>DO NOT PRELOAD</small>	1.0
	-Oakmoss absolute (O-001) <small>DO NOT PRELOAD</small>	1.0
29.	GLUTARAL ² <small>DO NOT PRELOAD</small>	0.5 pet G-003B
30.	2-BROMO-2-NITROPROPANE-1,3-DIOL	0.5 pet B-015B
31.	Sesquiterpene lactone mix ¹	0.1 pet Mx-18
	-Alantolactone (A-003)	0.033
	-Costunolide (C-039)	0.033
	-Dehydrocostus lactone (D-056)	0.033
32.	THIMEROSAL	0.1 pet T-007
33.	Propolis ¹	10.0 pet P-022
34.	BENZOPHENONE-3	10.0 pet H-014C
35.	CHLOROXYLENOL (PCMX)	1.0 pet C-010B
36.	Ethyleneurea, melamine formaldehyde mix ² <small>DO NOT PRELOAD</small>	5.0 pet Mx-16
	-Dimethylol dihydroxy ethylene urea (D-012) <small>DO NOT PRELOAD</small>	4.0
	-Melamine formaldehyde (M-001) <small>DO NOT PRELOAD</small>	1.0
37.	2-tert-Butyl-4-methoxyphenol (BHA)	2.0 pet B-022
38.	Gold(I)sodium thiosulfate dihydrate	0.5 pet G-005A
39.	Ethyl acrylate <small>DO NOT PRELOAD</small>	0.1 pet E-004
40.	GLYCERYL THIOGLYCOLATE <small>DO NOT PRELOAD</small>	1.0 pet G-004
41.	Toluenesulfonamide formaldehyde resin	10.0 pet T-010
42.	Methyl methacrylate <small>DO NOT PRELOAD</small>	2.0 pet M-013
43.	Cobalt(II)chloride hexahydrate ¹	1.0 pet C-017A
44.	Tixocortol-21-pivalate	1.0 pet T-031A

Compound	Conc. Veh. %(w/w)	Art. No.
45. Budesonide	0.1 pet	B-033A
46. COCAMIDE DEA	0.5 pet	C-019
47. TRIETHANOLAMINE	2.0 pet	T-016
48. Textile dye mix ¹	6.6 pet	Mx-30
-Dipperse Blue 35 (D-027)	1.0	
-Dipperse Orange 1 (D-031)	1.0	
-DISPERSE ORANGE 3 (D-032)	1.0	
-Disperse Red 1 (D-034)	1.0	
-DISPERSE RED 17 (D-035)	1.0	
-Disperse Yellow 3 (D-036)	1.0	
-Disperse Blue 106 (D-040)	0.3	
-Disperse Blue 124 (D-041)	0.3	
49. Tea tree oil oxidized <small>DO NOT PRELOAD</small>	5.0 pet	T-035B
50. Fragrance mix II ¹ <small>DO NOT PRELOAD</small>	14.0 pet	Mx-25
-Hexyl cinnamic aldehyde (H-025)	5.0	
-COUMARIN (C-038)	2.5	
-FARNESOL (F-004)	2.5	
-HYDROXYISOHEXYL 3-CYCLOHEXENE CARBOXALDEHYDE (L-003)	2.5	
-CITRAL (C-036)	1.0	
-CITRONELLOL (C-037) <small>DO NOT PRELOAD</small>	0.5	
51. Disperse Yellow 3	1.0 pet	D-036
52. BENZYL SALICYLATE	10.0 pet	B-010B
53. DECYL GLUCOSIDE ⁴ <small>DO NOT PRELOAD</small>	5.0 pet	D-065
54. METHYLISOTHIAZOLINONE ¹ <small>DO NOT PRELOAD</small>	0.2 aq	M-035B
55. 2-Hydroxyethyl methacrylate ¹ <small>DO NOT PRELOAD</small>	2.0 pet	H-010
56. DMDM HYDANTOIN ³ <small>DO NOT PRELOAD</small>	1.0 pet	D-047B
57. Ylang ylang oil <small>DO NOT PRELOAD</small>	2.0 pet	Y-001
58. BENZYL ALCOHOL <small>DO NOT PRELOAD</small>	10.0 sof	B-008B
59. ISOPROPYL MYRISTATE	20.0 pet	I-003
60. Hydroperoxides of Limonene <small>DO NOT PRELOAD</small>	0.3 pet	H-032A
61. Desoximetasone	1.0 pet	D-057
62. POLYSORBATE 80	5.0 pet	P-013
63. IODOPROPYNYL BUTYLCARBAMATE	0.2 pet	I-008C
64. 2-n-Octyl-4-isothiazolin-3-one <small>DO NOT PRELOAD</small>	0.1 pet	O-004
65. Disperse Blue mix 106/124	1.0 pet	Mx-26
-Disperse Blue 106 (D-040)	0.5	
-Disperse Blue 124 (D-041)	0.5	
66. Compositae mix II <small>DO NOT PRELOAD</small>	5.0 pet	Mx-29A
-Anthemis nobilis extract (C-029) <small>DO NOT PRELOAD</small>	1.2	
-Chamomilla recutita extract (C-051) <small>DO NOT PRELOAD</small>	1.2	

Compound	Conc. Veh. %(w/w)	Art. No.
-Achillea millefolium extract (A-025) <small>DO NOT PRELOAD</small>	1.0	
-Tanacetum vulgare extract (T-033) <small>DO NOT PRELOAD</small>	1.0	
-Arnica montana extract (A-024) <small>DO NOT PRELOAD</small>	0.5	
-Parthenolide (P-029)	0.1	
67. Lidocaine	15.0 pet	L-002B
68. Fusidic acid sodium salt	2.0 pet	F-003
69. Dibucaine hydrochloride	2.5 pet	D-005B
70. Benzoylperoxide	1.0 pet	B-007
71. ISOAMYL p-METHOXYCINNAMATE	10.0 pet	I-009
72. HYDROXYISOHEXYL 3-CYCLOHEXENE CARBOXALDEHYDE ¹	5.0 pet	L-003
73. ETHYLHEXYL SALICYLATE	5.0 pet	O-007A
74. Hydroperoxides of Linalool <small>DO NOT PRELOAD</small>	1.0 pet	H-031A
75. Amidoamine <small>DO NOT PRELOAD</small>	0.1 aq	A-029
76. COCAMIDOPROPYL BETAINE <small>DO NOT PRELOAD</small>	1.0 aq	C-018
77. FORMALDEHYDE ¹ <small>DO NOT PRELOAD</small>	2.0 aq	F-002B
78. METHYLISOTHIAZOLINONE + METHYLCHLOROISOTHIAZOLINONE ¹ <small>DO NOT PRELOAD</small>	0.02 aq	C-009B
79. PROPYLENE GLYCOL <small>DO NOT PRELOAD</small>	30.0 aq	P-019B
80. OLEAMIDOPROPYL DIMETHYLAMINE <small>DO NOT PRELOAD</small>	0.1 aq	O-005

Revised January 2018

Latin American Baseline Series LA-1000

1. Potassium dichromate ¹	0.5 pet	P-014A
2. p-PHENYLENEDIAMINE (PPD) ¹	1.0 pet	P-006
3. Thiuram mix ¹	1.0 pet	Mx-01
-Dipentamethylenethiuram disulfide (D-019)	0.25	
-Tetraethylthiuram disulfide (TETD) (T-002)	0.25	
-Tetramethylthiuram disulfide (TMTD) (T-005)	0.25	
-Tetramethylthiuram monosulfide (TMTM) (T-006)	0.25	
4. Neomycin sulfate ¹	20.0 pet	N-001
5. Cobalt(II)chloride hexahydrate ¹	1.0 pet	C-017A
6. Caine mix III ¹	10.0 pet	Mx-19
-Benzocaine (B-004)	5.0	
-Dibucaine hydrochloride (D-005)	2.5	
-Tetracaine hydrochloride (T-025)	2.5	
7. Nickel(II)sulfate hexahydrate ¹	5.0 pet	N-002A
8. Clioquinol	5.0 pet	C-015
9. COLOPHONIUM ¹	20.0 pet	C-020

Compound	Conc. Veh. %(w/w)	Art. No.
10. Paraben mix ¹	16.0 pet	Mx-03C
-BUTYLPARABEN (B-020)	4.0	
-ETHYLPARABEN (E-010)	4.0	
-METHYLPARABEN (M-012)	4.0	
-PROPYLPARABEN (P-020)	4.0	
11. N-Isopropyl-N-phenyl-4-phenylenediamine (IPPD) ¹	0.1 pet	I-004
12. LANOLIN ALCOHOL ¹	30.0 pet	W-001
13. Mercapto mix ¹	2.0 pet	Mx-05A
-N-Cyclohexyl-2-benzothiazolylsulfenamide (C-023)	0.5	
-Dibenzothiazyl disulfide (MBTS) (D-003)	0.5	
-2-Mercaptobenzothiazole (MBT) (M-003)	0.5	
-2-(4-Morpholinylmercapto)benzothiazol (MOR) (M-016)	0.5	
14. Epoxy resin, Bisphenol A ¹	1.0 pet	E-002
15. Peru balsam ^{1,2} <small>DO NOT PRELOAD</small>	25.0 pet	B-001
16. 4-tert-Butylphenolformaldehyde resin (PTBP) ¹	1.0 pet	B-024
17. 2-Mercaptobenzothiazole (MBT) ¹	2.0 pet	M-003A
18. FORMALDEHYDE <small>DO NOT PRELOAD</small>	1.0 pet	F-002C
19. Fragrance mix ^{1,2} <small>DO NOT PRELOAD</small>	8.0 pet	Mx-07
-AMYL CINNAMAL (A-014)	1.0	
-CINNAMYL ALCOHOL (C-013) <small>DO NOT PRELOAD</small>	1.0	
-CINNAMAL (C-014) <small>DO NOT PRELOAD</small>	1.0	
-EUGENOL (E-016) <small>DO NOT PRELOAD</small>	1.0	
-GERANIOL (G-001) <small>DO NOT PRELOAD</small>	1.0	
-HYDROXYCITRONELLAL (H-008)	1.0	
-ISOEUGENOL (I-002) <small>DO NOT PRELOAD</small>	1.0	
-Oakmoss absolute (O-001) <small>DO NOT PRELOAD</small>	1.0	
20. Sesquiterpene lactone mix ¹	0.1 pet	Mx-18
-Alantolactone (A-003)	0.033	
-Costunolide (C-039)	0.033	
-Dehydrocostus lactone (D-056)	0.033	
21. QUATERNIUM-15 ¹	1.0 pet	C-007A
22. 2-Methoxy-6-n-pentyl-4-benzoquinone	0.01 pet	M-008
23. METHYLISOTHIAZOLINONE + METHYLCHLOROISOTHIAZOLINONE <small>DO NOT PRELOAD</small>	0.01 aq	C-009A
24. Budesonide ¹	0.01 pet	B-033B
25. Tixocortol-21-pivalate ¹	0.1 pet	T-031B
26. METHYLDIBROMO GLUTARONITRILE ¹	0.5 pet	D-049E
27. Fragrance mix II ¹ <small>DO NOT PRELOAD</small>	14.0 pet	Mx-25

Compound	Conc. Veh. %(w/w)	Art. No.
-Hexyl cinnamic aldehyde (H-025)	5.0	
-COUMARIN (C-038)	2.5	
-FARNESOL (F-004)	2.5	
-HYDROXYISOHEXYL 3-CYCLOHEXENE CARBOXALDEHYDE (L-003)	2.5	
-CITRAL (C-036)	1.0	
-CITRONELLOL (C-037) <small>DO NOT PRELOAD</small>	0.5	
28. HYDROXYISOHEXYL 3-CYCLOHEXENE CARBOXALDEHYDE ¹	5.0 pet	L-003
29. Toluenesulfonamide formaldehyde resin	10.0 pet	T-010
30. COCAMIDOPROPYL BETAINE <small>DO NOT PRELOAD</small>	1.0 aq	C-018
31. DIAZOLIDINYL UREA	2.0 pet	D-044A
32. PROPYL GALLATE	1.0 pet	P-021
33. Sodium tetrachloropalladate(II) hydrate	3.0 pet	S-017
34. THIMEROSAL	0.1 pet	T-007
35. Disperse Blue mix 106/124	1.0 pet	Mx-26
-Disperse Blue 106 (D-040)	0.5	
-Disperse Blue 124 (D-041)	0.5	
36. Mixed dialkyl thiourea	1.0 pet	Mx-24
-N,N'-Dibutylthiourea (D-038)	0.5	
-N,N'-Diethylthiourea (D-039)	0.5	
37. METHYLISOTHIAZOLINONE ¹	0.2 aq	M-035B
38. Carba mix	3.0 pet	Mx-06
-1,3-Diphenylguanidine (D-022)	1.0	
-ZINC DIBUTYLDITHIOCARBAMATE (ZBC) (Z-002)	1.0	
-Zinc diethyldithiocarbamate (ZDC) (Z-003)	1.0	
39. Hydrocortisone-17-butyrate	1.0 pet	H-021B
40. IMIDAZOLIDINYL UREA	2.0 pet	I-001A
		Introduced 2015

North American Baseline Series NA-1000

1. Benzocaine	5.0 pet	B-004
2. Textile dye mix ¹	6.6 pet	Mx-30
-Dipperse Blue 35 (D-027)	1.0	
-Dipperse Orange 1 (D-031)	1.0	
-DISPERSE ORANGE 3 (D-032)	1.0	
-Disperse Red 1 (D-034)	1.0	
-DISPERSE RED 17 (D-035)	1.0	

Compound	Conc. Veh. %(w/w)	Art. No.	Compound	Conc. Veh. %(w/w)	Art. No.
-Disperse Yellow 3 (D-036)	1.0		-METHYLPARABEN (M-012)	3.0	
-Disperse Blue 106 (D-040)	0.3		-PROPYLPARABEN (P-020)	3.0	
-Disperse Blue 124 (D-041)	0.3		27. METHYLDIBROMO GLUTARONITRILE ¹	0.5	pet D-049E
3. COLOPHONIUM ¹	20.0	pet C-020	28. Fragrance mix I ^{1,2} <small>DO NOT PRELOAD</small>	8.0	pet Mx-07
4. p-PHENYLENEDIAMINE (PPD) ¹	1.0	pet P-006	-AMYL CINNAMAL (A-014)	1.0	
5. IMIDAZOLIDINYL UREA	2.0	pet I-001A	-CINNAMYL ALCOHOL (C-013) <small>DO NOT PRELOAD</small>	1.0	
6. CINNAMAL <small>DO NOT PRELOAD</small>	1.0	pet C-014	-CINNAMAL (C-014) <small>DO NOT PRELOAD</small>	1.0	
7. Amerchol L-101	50.0	pet A-004	-EUGENOL (E-016) <small>DO NOT PRELOAD</small>	1.0	
8. Carba mix	3.0	pet Mx-06	-GERANIOL (G-001) <small>DO NOT PRELOAD</small>	1.0	
-1,3-Diphenylguanidine (D-022)	1.0		-HYDROXYCITRONELLAL (H-008)	1.0	
-ZINC DIBUTYLDITHIOCARBAMATE (ZBC) (Z-002)	1.0		-ISOEUGENOL (I-002) <small>DO NOT PRELOAD</small>	1.0	
-Zinc diethyldithiocarbamate (ZDC) (Z-003)	1.0		-Oakmoss absolute (O-001) <small>DO NOT PRELOAD</small>	1.0	
9. Neomycin sulfate ¹	20.0	pet N-001	29. GLUTARAL ² <small>DO NOT PRELOAD</small>	0.5	pet G-003B
10. Thiuram mix ¹	1.0	pet Mx-01	30. 2-BROMO-2-NITROPROPANE-1,3-DIOL	0.5	pet B-015B
-Dipentamethylenethiuram disulfide (D-019)	0.25		31. Sesquiterpene lactone mix ¹	0.1	pet Mx-18
-Tetraethylthiuram disulfide (TETD) (T-002)	0.25		-Alantolactone (A-003)	0.033	
-Tetramethylthiuram disulfide (TMTD) (T-005)	0.25		-Costunolide (C-039)	0.033	
-Tetramethylthiuram monosulfide (TMTM) (T-006)	0.25		-Dehydrocostus lactone (D-056)	0.033	
11. FORMALDEHYDE ¹ <small>DO NOT PRELOAD</small>	2.0	aq F-002B	32. Fragrance mix II ¹ <small>DO NOT PRELOAD</small>	14.0	pet Mx-25
12. Ethylenediamine dihydrochloride	1.0	pet E-005	-Hexyl cinnamic aldehyde (H-025)	5.0	
13. Epoxy resin, Bisphenol A ¹	1.0	pet E-002	-COUMARIN (C-038)	2.5	
14. QUATERNIUM-15 ¹	2.0	pet C-007B	-FARNESOL (F-004)	2.5	
15. 4-tert-Butylphenolformaldehyde resin (PTBP) ¹	1.0	pet B-024	-HYDROXYISOHEXYL 3-CYCLOHEXENE CARBOXALDEHYDE (L-003)	2.5	
16. Ylang ylang oil <small>DO NOT PRELOAD</small>	2.0	pet Y-001	-CITRAL (C-036)	1.0	
17. 1,3-Diphenylguanidine	1.0	pet D-022	-CITRONELLOL (C-037) <small>DO NOT PRELOAD</small>	0.5	
18. Potassium dichromate	0.25	pet P-014B	33. PROPYLENE GLYCOL <small>DO NOT PRELOAD</small>	30.0	aq P-019B
19. Peru balsam ^{1,2} <small>DO NOT PRELOAD</small>	25.0	pet B-001	34. 2-Hydroxyethyl methacrylate ¹ <small>DO NOT PRELOAD</small>	2.0	pet H-010
20. Nickel(II)sulfate hexahydrate	2.5	pet N-002B	35. Propolis ¹	10.0	pet P-022
21. DIAZOLIDINYL UREA	1.0	pet D-044C	36. Hydroperoxides of Limonene <small>DO NOT PRELOAD</small>	0.3	pet H-032A
22. DMDM HYDANTOIN	1.0	pet D-047B	37. IODOPROPYNYL BUTYLCARBAMATE	0.2	pet I-008C
23. Bacitracin	20.0	pet B-032B	38. Disperse Blue mix 106/124	1.0	pet Mx-26
24. Mixed dialkyl thiourea	1.0	pet Mx-24	-Disperse Blue 106 (D-040)	0.5	
-N,N'-Dibutylthiourea (D-038)	0.5		-Disperse Blue 124 (D-041)	0.5	
-N,N'-Diethylthiourea (D-039)	0.5		39. Ethyl acrylate <small>DO NOT PRELOAD</small>	0.1	pet E-004
25. METHYLISOTHIAZOLINONE + METHYLCHLOROISOTHIAZOLINONE ¹ <small>DO NOT PRELOAD</small>	0.02	aq C-009B	40. Hydroperoxides of Linalool <small>DO NOT PRELOAD</small>	1.0	pet H-031A
26. Paraben mix	12.0	pet Mx-03A	41. Toluenesulfonamide formaldehyde resin	10.0	pet T-010
-BUTYLPARABEN (B-020)	3.0		42. Methyl methacrylate <small>DO NOT PRELOAD</small>	2.0	pet M-013
-ETHYLPARABEN (E-010)	3.0		43. Cobalt(II)chloride hexahydrate ¹	1.0	pet C-017A
			44. Tixocortol-21-pivalate	0.1	pet T-031A

Compound	Conc. % (w/w)	Veh.	Art. No.
45. Budesonide	0.1	pet	B-033A
46. Compositae mix II <small>DO NOT PRELOAD</small>	5.0	pet	Mx-29A
-Anthemis nobilis extract (C-029) <small>DO NOT PRELOAD</small>	1.2		
-Chamomilla recutita extract (C-051) <small>DO NOT PRELOAD</small>	1.2		
-Achillea millefolium extract (A-025) <small>DO NOT PRELOAD</small>	1.0		
-Tanacetum vulgare extract (T-033) <small>DO NOT PRELOAD</small>	1.0		
-Arnica montana extract (A-024) <small>DO NOT PRELOAD</small>	0.5		
-Parthenolide (P-029)	0.1		
47. DECYL GLUCOSIDE ⁴ <small>DO NOT PRELOAD</small>	5.0	pet	D-065
48. OLEAMIDOPROPYL DIMETHYLAMINE <small>DO NOT PRELOAD</small>	0.1	aq	O-005
49. COCAMIDOPROPYL BETAINE <small>DO NOT PRELOAD</small>	1.0	aq	C-018
50. METHYLISOTHIAZOLINONE ¹ <small>DO NOT PRELOAD</small>	0.2	aq	M-035B

Revised January 2018

North American 65 Extended Series

NAE-65

1. Benzocaine	5.0	pet	B-004
2. 2-Mercaptobenzothiazole (MBT) ¹	1.0	pet	M-003B
3. COLOPHONIUM ¹	20.0	pet	C-020
4. p-PHENYLENEDIAMINE (PPD) ¹	1.0	pet	P-006
5. IMIDAZOLIDINYL UREA	2.0	pet	I-001A
6. CINNAMAL <small>DO NOT PRELOAD</small>	1.0	pet	C-014
7. Amerchol L-101	50.0	pet	A-004
8. Carba mix	3.0	pet	Mx-06
-1,3-Diphenylguanidine (D-022)	1.0		
-ZINC DIBUTYLDITHIOCARBAMATE (ZBC) (Z-002)	1.0		
-Zinc diethyldithiocarbamate (ZDC) (Z-003)	1.0		
9. Neomycin sulfate ¹	20.0	pet	N-001
10. Thiuram mix ¹	1.0	pet	Mx-01
-Dipentamethylenethiuram disulfide (D-019)	0.25		
-Tetraethylthiuram disulfide (TETD) (T-002)	0.25		
-Tetramethylthiuram disulfide (TMTD) (T-005)	0.25		
-Tetramethylthiuram monosulfide (TMTM) (T-006)	0.25		
11. FORMALDEHYDE <small>DO NOT PRELOAD</small>	2.0	aq	F-002B
12. Ethylenediamine dihydrochloride	1.0	pet	E-005
13. Epoxy resin, Bisphenol A ¹	1.0	pet	E-002
14. QUATERNIUM-15 ¹	2.0	pet	C-007B
15. 4-tert-Butylphenolformaldehyde resin (PTBP) ¹	1.0	pet	B-024

Compound	Conc. % (w/w)	Veh.	Art. No.
16. Mercapto mix	1.0	pet	Mx-05B
-N-Cyclohexyl-2-benzothiazolylsulfenamide (C-023)	0.25		
-Dibenzothiazyl disulfide (MBTS) (D-003)	0.25		
-2-Mercaptobenzothiazole (MBT) (M-003)	0.25		
-2-(4-Morpholinylmercapto)benzothiazol (MOR) (M-016)	0.25		
17. 1,3-Diphenylguanidine	1.0	pet	D-022
18. Potassium dichromate	0.25	pet	P-014B
19. Peru balsam	25.0	pet	B-001
20. Nickel(II)sulfate hexahydrate	2.5	pet	N-002B
21. DIAZOLIDINYL UREA	1.0	pet	D-044C
22. DMDM HYDANTOIN	1.0	pet	D-047B
23. Bacitracin	20.0	pet	B-032B
24. Mixed dialkyl thiourea	1.0	pet	Mx-24
-N,N'-Dibutylthiourea (D-038)	0.5		
-N,N'-Diethylthiourea (D-039)	0.5		
25. METHYLISOTHIAZOLINONE + METHYLCHLOROISOTHIAZOLINONE ¹ <small>DO NOT PRELOAD</small>	0.02	aq	C-009B
26. Paraben mix	12.0	pet	Mx-03A
-BUTYLPARABEN (B-020)	3.0		
-ETHYLPARABEN (E-010)	3.0		
-METHYLPARABEN (M-012)	3.0		
-PROPYLPARABEN (P-020)	3.0		
27. METHYLDIBROMO GLUTARONITRILE ¹	0.5	pet	D-049E
28. Fragrance mix I ^{1,2} <small>DO NOT PRELOAD</small>	8.0	pet	Mx-07
-AMYL CINNAMAL (A-014)	1.0		
-CINNAMYL ALCOHOL (C-013) <small>DO NOT PRELOAD</small>	1.0		
-CINNAMAL (C-014) <small>DO NOT PRELOAD</small>	1.0		
-EUGENOL (E-016) <small>DO NOT PRELOAD</small>	1.0		
-GERANIOL (G-001) <small>DO NOT PRELOAD</small>	1.0		
-HYDROXYCITRONELLAL (H-008)	1.0		
-ISOEUGENOL (I-002) <small>DO NOT PRELOAD</small>	1.0		
-Oakmoss absolute (O-001) <small>DO NOT PRELOAD</small>	1.0		
29. GLUTARAL ² <small>DO NOT PRELOAD</small>	0.5	pet	G-003B
30. 2-BROMO-2-NITROPROPANE-1,3-DIOL	0.5	pet	B-015B
31. Sesquiterpene lactone mix ¹	0.1	pet	Mx-18
-Alantolactone (A-003)	0.033		
-Costunolide (C-039)	0.033		
-Dehydrocostus lactone (D-056)	0.033		
32. Fragrance mix II ¹ <small>DO NOT PRELOAD</small>	14.0	pet	Mx-25

Compound	Conc. Veh. %(w/w)	Art. No.
-Hexyl cinnamic aldehyde (H-025)	5.0	
-COUMARIN (C-038)	2.5	
-FARNESOL (F-004)	2.5	
-HYDROXYISOHEXYL 3-CYCLOHEXENE CARBOXALDEHYDE (L-003)	2.5	
-CITRAL (C-036)	1.0	
-CITRONELLOL (C-037) <small>DO NOT PRELOAD</small>	0.5	
33. PROPYLENE GLYCOL <small>DO NOT PRELOAD</small>	30.0 aq	P-019B
34. BENZOPHENONE-3	10.0 pet	H-014C
35. CHLOROXYLENOL (PCMX)	1.0 pet	C-010B
36. Hydroperoxides of Limonene <small>DO NOT PRELOAD</small>	0.3 pet	H-032A
37. IODOPROPYNYL BUTYLCARBAMATE	0.2 pet	I-008C
38. Disperse Blue mix 106/124	1.0 pet	Mx-26
-Disperse Blue 106 (D-040)	0.5	
-Disperse Blue 124 (D-041)	0.5	
39. Ethyl acrylate <small>DO NOT PRELOAD</small>	0.1 pet	E-004
40. Hydroperoxides of Linalool <small>DO NOT PRELOAD</small>	1.0 pet	H-031A
41. Toluenesulfonamide formaldehyde resin	10.0 pet	T-010
42. Methyl methacrylate <small>DO NOT PRELOAD</small>	2.0 pet	M-013
43. Cobalt(II)chloride hexahydrate ¹	1.0 pet	C-017A
44. Tixocortol-21-pivalate	0.1 pet	T-031A
45. Budesonide	0.1 pet	B-033A
46. Compositae mix II <small>DO NOT PRELOAD</small>	5.0 pet	Mx-29A
-Anthemis nobilis extract (C-029) <small>DO NOT PRELOAD</small>	1.2	
-Chamomilla recutita extract (C-051) <small>DO NOT PRELOAD</small>	1.2	
-Achillea millefolium extract (A-025) <small>DO NOT PRELOAD</small>	1.0	
-Tanacetum vulgare extract (T-033) <small>DO NOT PRELOAD</small>	1.0	
-Arnica montana extract (A-024) <small>DO NOT PRELOAD</small>	0.5	
-Parthenolide (P-029)	0.1	
47. Textile dye mix ¹	6.6 pet	Mx-30
-Diperse Blue 35 (D-027)	1.0	
-Diperse Orange 1 (D-031)	1.0	
-DISPERSE ORANGE 3 (D-032)	1.0	
-Disperse Red 1 (D-034)	1.0	
-DISPERSE RED 17 (D-035)	1.0	
-Disperse Yellow 3 (D-036)	1.0	
-Disperse Blue 106 (D-040)	0.3	
-Disperse Blue 124 (D-041)	0.3	
48. OLEAMIDOPROPYL DIMETHYLAMINE <small>DO NOT PRELOAD</small>	0.1 aq	O-005
49. COCAMIDOPROPYL BETAINE <small>DO NOT PRELOAD</small>	1.0 aq	C-018
50. METHYLISOTHIAZOLINONE ¹ <small>DO NOT PRELOAD</small>	0.2 aq	M-035B

Compound	Conc. Veh. %(w/w)	Art. No.
51. Lidocaine	15.0 pet	L-002B
52. Dibucaine hydrochloride	2.5 pet	D-005B
53. DECYL GLUCOSIDE ⁴ <small>DO NOT PRELOAD</small>	5.0 pet	D-065
54. Clobetasol-17-propionate	1.0 pet	C-028
55. Amidoamine <small>DO NOT PRELOAD</small>	0.1 aq	A-029
56. 2-Hydroxyethyl methacrylate ¹ <small>DO NOT PRELOAD</small>	2.0 pet	H-010
57. Desoximetasone	1.0 pet	D-057
58. HYDROXYISOHEXYL 3-CYCLOHEXENE CARBOXALDEHYDE ¹	5.0 pet	L-003
59. BENZYL ALCOHOL <small>DO NOT PRELOAD</small>	10.0 sof	B-008B
60. TOCOPHEROL <small>DO NOT PRELOAD</small>	100	T-036
61. Propolis ¹	10.0 pet	P-022
62. Fusidic acid sodium salt	2.0 pet	F-003
63. COCAMIDE DEA	0.5 pet	C-019
64. Tea tree oil oxidized <small>DO NOT PRELOAD</small>	5.0 pet	T-035B
65. Ylang ylang oil <small>DO NOT PRELOAD</small>	2.0 pet	Y-001

Revised January 2018

North American 80 Comprehensive Series

NAC-80

1. Benzocaine	5.0 pet	B-004
2. 2-Mercaptobenzothiazole (MBT)	1.0 pet	M-003B
3. COLOPHONIUM ¹	20.0 pet	C-020
4. p-PHENYLENEDIAMINE (PPD) ¹	1.0 pet	P-006
5. IMIDAZOLIDINYL UREA	2.0 pet	I-001A
6. CINNAMAL <small>DO NOT PRELOAD</small>	1.0 pet	C-014
7. Amerchol L-101	50.0 pet	A-004
8. Carba mix	3.0 pet	Mx-06
-1,3-Diphenylguanidine (D-022)	1.0	
-ZINC DIBUTYLDITHIOCARBAMATE (ZBC) (Z-002)	1.0	
-Zinc diethyldithiocarbamate (ZDC) (Z-003)	1.0	
9. Neomycin sulfate ¹	20.0 pet	N-001
10. Thiuram mix ¹	1.0 pet	Mx-01
-Dipentamethylenethiuram disulfide (D-019)	0.25	
-Tetraethylthiuram disulfide (TETD) (T-002)	0.25	
-Tetramethylthiuram disulfide (TMTD) (T-005)	0.25	
-Tetramethylthiuram monosulfide (TMTM) (T-006)	0.25	

Compound	Conc. Veh. %(w/w)	Art. No.
11. Clobetasol-17-propionate	1.0 pet	C-028
12. Ethylenediamine dihydrochloride	1.0 pet	E-005
13. Epoxy resin, Bisphenol A ¹	1.0 pet	E-002
14. QUATERNIUM-15 ¹	2.0 pet	C-007B
15. 4-tert-Butylphenolformaldehyde resin (PTBP) ¹	1.0 pet	B-024
16. Mercapto mix	1.0 pet	Mx-05B
-N-Cyclohexyl-2-benzothiazolylsulfenamide (C-023)	0.25	
-Dibenzothiazyl disulfide (MBTS) (D-003)	0.25	
-2-Mercaptobenzothiazole (MBT) (M-003)	0.25	
-2-(4-Morpholinylmercapto)benzothiazol (MOR) (M-016)	0.25	
17. 1,3-Diphenylguanidine	1.0 pet	D-022
18. Potassium dichromate	0.25 pet	P-014B
19. Peru balsam ^{1,2} <small>DO NOT PRELOAD</small>	25.0 pet	B-001
20. Nickel(II)sulfate hexahydrate	2.5 pet	N-002B
21. DIAZOLIDINYL UREA	1.0 pet	D-044C
22. TOCOPHEROL <small>DO NOT PRELOAD</small>	100	T-036
23. Bacitracin	20.0 pet	B-032B
24. Mixed dialkyl thiourea	1.0 pet	Mx-24
-N,N'-Dibutylthiourea (D-038)	0.5	
-N,N'-Diethylthiourea (D-039)	0.5	
25. DISPERSE ORANGE 3	1.0 pet	D-032
26. Paraben mix	12.0 pet	Mx-03A
-BUTYLPARABEN (B-020)	3.0	
-ETHYLPARABEN (E-010)	3.0	
-METHYLPARABEN (M-012)	3.0	
-PROPYLPARABEN (P-020)	3.0	
27. METHYLDIBROMO GLUTARONITRILE ¹	0.5 pet	D-049E
28. Fragrance mix ^{1,2} <small>DO NOT PRELOAD</small>	8.0 pet	Mx-07
-AMYL CINNAMAL (A-014)	1.0	
-CINNAMYL ALCOHOL (C-013) <small>DO NOT PRELOAD</small>	1.0	
-CINNAMAL (C-014) <small>DO NOT PRELOAD</small>	1.0	
-EUGENOL (E-016) <small>DO NOT PRELOAD</small>	1.0	
-GERANIOL (G-001) <small>DO NOT PRELOAD</small>	1.0	
-HYDROXYCITRONELLAL (H-008)	1.0	
-ISOEUGENOL (I-002) <small>DO NOT PRELOAD</small>	1.0	
-Oakmoss absolute (O-001) <small>DO NOT PRELOAD</small>	1.0	
29. GLUTARAL ² <small>DO NOT PRELOAD</small>	0.5 pet	G-003B
30. 2-BROMO-2-NITROPROPANE-1,3-DIOL	0.5 pet	B-015B
31. Sesquiterpene lactone mix ¹	0.1 pet	Mx-18

Compound	Conc. Veh. %(w/w)	Art. No.
-Alantolactone (A-003)	0.033	
-Costunolide (C-039)	0.033	
-Dehydrocostus lactone (D-056)	0.033	
32. THIMEROSAL	0.1 pet	T-007
33. Propolis ¹	10.0 pet	P-022
34. BENZOPHENONE-3	10.0 pet	H-014C
35. CHLOROXYLENOL (PCMX)	1.0 pet	C-010B
36. Ethyleneurea, melamine formaldehyde mix ² <small>DO NOT PRELOAD</small>	5.0 pet	Mx-16
-Dimethylol dihydroxy ethylene urea (D-012) <small>DO NOT PRELOAD</small>	4.0	
-Melamine formaldehyde (M-001) <small>DO NOT PRELOAD</small>	1.0	
37. 2-tert-Butyl-4-methoxyphenol (BHA)	2.0 pet	B-022
38. Gold(I)sodium thiosulfate dihydrate	0.5 pet	G-005A
39. Ethyl acrylate <small>DO NOT PRELOAD</small>	0.1 pet	E-004
40. GLYCERYL THIOGLYCOLATE <small>DO NOT PRELOAD</small>	1.0 pet	G-004
41. Toluenesulfonamide formaldehyde resin	10.0 pet	T-010
42. Methyl methacrylate <small>DO NOT PRELOAD</small>	2.0 pet	M-013
43. Cobalt(II)chloride hexahydrate ¹	1.0 pet	C-017A
44. Tixocortol-21-pivalate	1.0 pet	T-031A
45. Budesonide	0.1 pet	B-033A
46. COCAMIDE DEA	0.5 pet	C-019
47. TRIETHANOLAMINE	2.0 pet	T-016
48. Textile dye mix ¹	6.6 pet	Mx-30
-Diperse Blue 35 (D-027)	1.0	
-Diperse Orange 1 (D-031)	1.0	
-DISPERSE ORANGE 3 (D-032)	1.0	
-Disperse Red 1 (D-034)	1.0	
-DISPERSE RED 17 (D-035)	1.0	
-Disperse Yellow 3 (D-036)	1.0	
-Disperse Blue 106 (D-040)	0.3	
-Disperse Blue 124 (D-041)	0.3	
49. Tea tree oil oxidized <small>DO NOT PRELOAD</small>	5.0 pet	T-035B
50. Fragrance mix II ¹ <small>DO NOT PRELOAD</small>	14.0 pet	Mx-25
-Hexyl cinnamic aldehyde (H-025)	5.0	
-COUMARIN (C-038)	2.5	
-FARNESOL (F-004)	2.5	
-HYDROXYISOHEXYL 3-CYCLOHEXENE CARBOXALDEHYDE (L-003)	2.5	
-CITRAL (C-036)	1.0	
-CITRONELLOL (C-037) <small>DO NOT PRELOAD</small>	0.5	
51. Disperse Yellow 3	1.0 pet	D-036
52. BENZYL SALICYLATE	10.0 pet	B-010B
53. DECYL GLUCOSIDE ⁴ <small>DO NOT PRELOAD</small>	5.0 pet	D-065

Compound

Compound	Conc. % (w/w)	Veh.	Art. No.
54. METHYLISOTHIAZOLINONE ¹ <small>DO NOT PRELOAD</small>	0.2	aq	M-035B
55. 2-Hydroxyethyl methacrylate ¹ <small>DO NOT PRELOAD</small>	2.0	pet	H-010
56. DMDM HYDANTOIN ³ <small>DO NOT PRELOAD</small>	1.0	pet	D-047B
57. Ylang ylang oil <small>DO NOT PRELOAD</small>	2.0	pet	Y-001
58. BENZYL ALCOHOL <small>DO NOT PRELOAD</small>	10.0	sof	B-008B
59. ISOPROPYL MYRISTATE	20.0	pet	I-003
60. Hydroperoxides of Limonene <small>DO NOT PRELOAD</small>	0.3	pet	H-032A
61. Desoximetasone	1.0	pet	D-057
62. POLYSORBATE 80	5.0	pet	P-013
63. IODOPROPYNYL BUTYLCARBAMATE	0.2	pet	I-008C
64. 2-n-Octyl-4-isothiazolin-3-one <small>DO NOT PRELOAD</small>	0.1	pet	O-004
65. Disperse Blue mix 106/124	1.0	pet	Mx-26
-Disperse Blue 106 (D-040)	0.5		
-Disperse Blue 124 (D-041)	0.5		
66. Compositae mix II <small>DO NOT PRELOAD</small>	5.0	pet	Mx-29A
-Anthemis nobilis extract (C-029) <small>DO NOT PRELOAD</small>	1.2		
-Chamomilla recutita extract (C-051) <small>DO NOT PRELOAD</small>	1.2		
-Achillea millefolium extract (A-025) <small>DO NOT PRELOAD</small>	1.0		
-Tanacetum vulgare extract (T-033) <small>DO NOT PRELOAD</small>	1.0		
-Arnica montana extract (A-024) <small>DO NOT PRELOAD</small>	0.5		
-Parthenolide (P-029)	0.1		
67. Lidocaine	15.0	pet	L-002B
68. Fusidic acid sodium salt	2.0	pet	F-003
69. Dibucaine hydrochloride	2.5	pet	D-005B
70. Benzoylperoxide	1.0	pet	B-007
71. ISOAMYL p-METHOXYCINNAMATE	10.0	pet	I-009
72. HYDROXYISOHEXYL 3-CYCLOHEXENE CARBOXYALDEHYDE ¹	5.0	pet	L-003
73. ETHYLHEXYL SALICYLATE	5.0	pet	O-007A
74. Hydroperoxides of Linalool <small>DO NOT PRELOAD</small>	1.0	pet	H-031A
75. Amidoamine <small>DO NOT PRELOAD</small>	0.1	aq	A-029
76. COCAMIDOPROPYL BETAINE <small>DO NOT PRELOAD</small>	1.0	aq	C-018
77. FORMALDEHYDE ¹ <small>DO NOT PRELOAD</small>	2.0	aq	F-002B
78. METHYLISOTHIAZOLINONE + METHYLCHLOROISOTHIAZOLINONE ¹ <small>DO NOT PRELOAD</small>	0.02	aq	C-009B
79. PROPYLENE GLYCOL <small>DO NOT PRELOAD</small>	30.0	aq	P-019B
80. OLEAMIDOPROPYL DIMETHYLAMINE <small>DO NOT PRELOAD</small>	0.1	aq	O-005

Revised January 2018

American Core Series

AC-1000

1. Nickel(II)sulfate hexahydrate	2.5	pet	N-002B
2. Amerchol L-101	50.0	pet	A-004
3. Neomycin sulfate ¹	20.0	pet	N-001
4. Potassium dichromate	0.25	pet	P-014B
5. DMDM HYDANTOIN ³ <small>DO NOT PRELOAD</small>	1.0	pet	D-047B
6. Fragrance mix I ^{1,2} <small>DO NOT PRELOAD</small>	8.0	pet	Mx-07
-AMYL CINNAMAL (A-014)	1.0		
-CINNAMYL ALCOHOL (C-013) <small>DO NOT PRELOAD</small>	1.0		
-CINNAMAL (C-014) <small>DO NOT PRELOAD</small>	1.0		
-EUGENOL (E-016) <small>DO NOT PRELOAD</small>	1.0		
-GERANIOL (G-001) <small>DO NOT PRELOAD</small>	1.0		
-HYDROXYCITRONELLAL (H-008)	1.0		
-ISOEUGENOL (I-002) <small>DO NOT PRELOAD</small>	1.0		
-Oakmoss absolute (O-001) <small>DO NOT PRELOAD</small>	1.0		
7. COLOPHONIUM ¹	20.0	pet	C-020
8. Paraben mix	12.0	pet	Mx-03A
-BUTYLPARABEN (B-020)	3.0		
-ETHYLPARABEN (E-010)	3.0		
-METHYLPARABEN (M-012)	3.0		
-PROPYLPARABEN (P-020)	3.0		
9. METHYLISOTHIAZOLINONE ¹ <small>DO NOT PRELOAD</small>	0.2	aq	M-035B
10. Peru balsam ^{1,2} <small>DO NOT PRELOAD</small>	25.0	pet	B-001
11. Ethylenediamine dihydrochloride	1.0	pet	E-005
12. Cobalt(II)chloride hexahydrate ¹	1.0	pet	C-017A
13. 4-tert-Butylphenolformaldehyde resin (PTBP) ¹	1.0	pet	B-024
14. Epoxy resin, Bisphenol A ¹	1.0	pet	E-002
15. Carba mix	3.0	pet	Mx-06
-1,3-Diphenylguanidine (D-022)	1.0		
-ZINC DIBUTYLDITHIOCARBAMATE (ZBC) (Z-002)	1.0		
-Zinc diethyldithiocarbamate (ZDC) (Z-003)	1.0		
16. Black rubber mix	0.6	pet	Mx-04
- N-Cyclohexyl-N-phenyl-4-phenylenediamine (C-024)	0.25		
- N,N'-Diphenyl-p-phenylenediamine (D-024)	0.25		
- N-Isopropyl-N-phenyl-4-phenylenediamine (IPPD) (I-004)	0.1		
17. METHYLISOTHIAZOLINONE + METHYLCHLOROISOTHIAZOLINONE ¹ <small>DO NOT PRELOAD</small>	0.01	aq	C-009A
18. QUATERNIUM-15 ¹	2.0	pet	C-007B

Compound	Conc. Veh. %(w/w)	Art. No.	Compound	Conc. Veh. %(w/w)	Art. No.
19. Hydroperoxides of Linalool <small>(DO NOT PRELOAD)</small>	0.5	pet H-031B	40. COCAMIDOPROPYL BETAINE <small>(DO NOT PRELOAD)</small>	1.0	aq C-018
20. p-PHENYLENEDIAMINE (PPD) ¹	1.0	pet P-006	41. Mixed dialkyl thiourea	1.0	pet Mx-24
21. FORMALDEHYDE ¹ <small>(DO NOT PRELOAD)</small>	2.0	aq F-002B	-N,N'-Dibutylthiourea (D-038)	0.5	
22. Mercapto mix	1.0	pet Mx-05B	-N,N'-Diethylthiourea (D-039)	0.5	
-N-Cyclohexyl-2-benzothiazolylsulfenamide (C-023)	0.25		42. 3-(Dimethylamino)-1-propylamine <small>(DO NOT PRELOAD)</small>	1.0	aq D-053
-Dibenzothiazyl disulfide (MBTS) (D-003)	0.25		43. 2-Hydroxyethyl methacrylate ¹ <small>(DO NOT PRELOAD)</small>	2.0	pet H-010
-2-Mercaptobenzothiazole (MBT) (M-003)	0.25		44. OLEAMIDOPROPYL DIMETHYLAMINE <small>(DO NOT PRELOAD)</small>	0.1	aq O-005
-2-(4-Morpholinylmercapto)benzothiazol (MOR) (M-016)	0.25		45. DECYL GLUCOSIDE ⁴ <small>(DO NOT PRELOAD)</small>	5.0	pet D-065
23. 2-BROMO-2-NITROPROPANE-1,3-DIOL	0.5	pet B-015B	46. Methyl methacrylate <small>(DO NOT PRELOAD)</small>	2.0	pet M-013
24. Thiuram mix ¹	1.0	pet Mx-01	47. Lavender absolute <small>(DO NOT PRELOAD)</small>	2.0	pet L-001
-Dipentamethylenethiuram disulfide (D-019)	0.25		48. CINNAMAL <small>(DO NOT PRELOAD)</small>	1.0	pet C-014
-Tetraethylthiuram disulfide (TETD) (T-002)	0.25		49. TOCOPHEROL <small>(DO NOT PRELOAD)</small>	100	T-036
-Tetramethylthiuram disulfide (TMTD) (T-005)	0.25		50. Ethyl acrylate <small>(DO NOT PRELOAD)</small>	0.1	pet E-004
-Tetramethylthiuram monosulfide (TMTM) (T-006)	0.25		51. Tea tree oil oxidized <small>(DO NOT PRELOAD)</small>	5.0	pet T-035B
25. DIAZOLIDINYL UREA	1.0	pet D-044C	52. CHLORHEXIDINE DIGLUCONATE <small>(DO NOT PRELOAD)</small>	0.5	aq C-005
26. Benzocaine	5.0	pet B-004	53. Propolis ¹	10.0	pet P-022
27. Tixocortol-21-pivalate	1.0	pet T-031A	54. CHLOROXYLENOL (PCMX)	1.0	pet C-010B
28. Gold(I)sodium thiosulfate dihydrate	2.0	pet G-005B	55. BENZOPHENONE-3	10.0	pet H-014C
29. IMIDAZOLIDINYL UREA	2.0	pet I-001A	56. Toluenesulfonamide formaldehyde resin	10.0	pet T-010
30. Budesonide	0.1	pet B-033A	Sesquiterpene lactone mix ¹	0.1	pet Mx-18
31. Hydrocortisone-17-butyrate	1.0	pet H-021B	-Alantolactone (A-003)	0.033	
32. 2-Mercaptobenzothiazole (MBT)	1.0	pet M-003B	-Costunolide (C-039)	0.033	
33. Bacitracin	20.0	pet B-032B	-Dehydrocostus lactone (D-056)	0.033	
34. Fragrance mix II ¹ <small>(DO NOT PRELOAD)</small>	14.0	pet Mx-25	58. COCAMIDE DEA	0.5	pet C-019
-Hexyl cinnamic aldehyde (H-025)	5.0		59. Hydroperoxides of Limonene <small>(DO NOT PRELOAD)</small>	0.2	pet H-032B
-COUMARIN (C-038)	2.5		60. BENZALKONIUM CHLORIDE <small>(DO NOT PRELOAD)</small>	0.1	aq B-027
-FARNESOL (F-004)	2.5		61. BENZOPHENONE-4	2.0	pet H-023C
-HYDROXYISOHEXYL 3-CYCLOHEXENE CARBOXALDEHYDE (L-003)	2.5		62. SODIUM BENZOATE	5.0	pet S-001
-CITRAL (C-036)	1.0		63. SORBIC ACID	2.0	pet S-003
-CITRONELLOL (C-037) <small>(DO NOT PRELOAD)</small>	0.5		64. Ylang ylang oil <small>(DO NOT PRELOAD)</small>	2.0	pet Y-001
35. Disperse Blue mix 106/124	1.0	pet Mx-26	65. Compositae mix II <small>(DO NOT PRELOAD)</small>	5.0	pet Mx-29A
-Disperse Blue 106 (D-040)	0.5		-Anthemis nobilis extract (C-029) <small>(DO NOT PRELOAD)</small>	1.2	
-Disperse Blue 124 (D-041)	0.5		-Chamomilla recutita extract (C-051) <small>(DO NOT PRELOAD)</small>	1.2	
36. Lidocaine	15.0	pet L-002B	-Achillea millefolium extract (A-025) <small>(DO NOT PRELOAD)</small>	1.0	
37. PROPYLENE GLYCOL <small>(DO NOT PRELOAD)</small>	30.0	aq P-019B	-Tanacetum vulgare extract (T-033) <small>(DO NOT PRELOAD)</small>	1.0	
38. IODOPROPYNYL BUTYLCARBAMATE	0.2	pet I-008C	-Arnica montana extract (A-024) <small>(DO NOT PRELOAD)</small>	0.5	
39. Polymyxin B sulfate	5.0	pet P-026	-Parthenolide (P-029)	0.1	
			66. Ethyleneurea, melamine formaldehyde mix ² <small>(DO NOT PRELOAD)</small>	5.0	pet Mx-16
			-Dimethylol dihydroxy ethylene urea (D-012) <small>(DO NOT PRELOAD)</small>	4.0	
			-Melamine formaldehyde (M-001) <small>(DO NOT PRELOAD)</small>	1.0	
			67. SORBITAN SESQUIOLEATE	20.0	pet S-005

Compound	Conc. Veh. %(w/w)	Art. No.
68. 1,3-Diphenylguanidine	1.0 pet	D-022
69. HYDROXYISOHEXYL 3-CYCLOHEXENE CARBOXALDEHYDE EC.1	5.0 pet	L-003
70. ETHYLHEXYLGLYCERIN	5.0 pet	E-027
71. Triamcinolone acetonide	1.0 pet	T-030
72. Clobetasol-17-propionate	1.0 pet	C-028
73. Amidoamine <small>DO NOT PRELOAD</small>	0.1 aq	A-029
74. ETHYL CYANOACRYLATE <small>DO NOT PRELOAD</small>	10.0 pet	E-023
75. PHENOXYETHANOL <small>DO NOT PRELOAD</small>	1.0 pet	P-025
76. DISPERSE ORANGE 3	1.0 pet	D-032
77. BENZOIC ACID	5.0 pet	B-005
78. BHT	2.0 pet	D-006
79. ETHYLHEXYL METHOXYCINNAMATE	10.0 pet	E-019C
80. BENZYL ALCOHOL <small>DO NOT PRELOAD</small>	10.0 sof	B-008B
81. CETEARYL ALCOHOL	20.0 pet	C-033
82. Carmine	2.5 pet	C-059
83. BENZYL SALICYLATE	10.0 pet	B-010B
84. Disperse Yellow 3	1.0 pet	D-036
85. Jasmine absolute <small>DO NOT PRELOAD</small>	2.0 pet	J-002
86. Peppermint oil <small>DO NOT PRELOAD</small>	2.0 pet	P-036
87. Pramoxine hydrochloride	2.0 pet	P-039
88. SHELLAC <small>DO NOT PRELOAD</small>	20.0 alc	S-015
89. LAURYL POLYGLUCOSE <small>DO NOT PRELOAD</small>	3.0 pet	L-004
90. p-CHLORO-m-CRESOL (PCMC)	1.0 pet	C-008

Revised January 2022

Compostion of International Screening Series

Bakery Series

B-1000

1. VANILLIN	10.0 pet	V-001
2. EUGENOL <small>DO NOT PRELOAD</small>	2.0 pet	E-016
3. ISOEUGENOL <small>DO NOT PRELOAD</small>	2.0 pet	I-002
4. SODIUM BENZOATE	5.0 pet	S-001
5. BHT	2.0 pet	D-006
6. MENTHOL <small>DO NOT PRELOAD</small>	2.0 pet	M-002
7. CINNAMYL ALCOHOL <small>DO NOT PRELOAD</small>	2.0 pet	C-013
8. CINNAMAL <small>DO NOT PRELOAD</small>	1.0 pet	C-014
9. 2-tert-Butyl-4-methoxyphenol (BHA)	2.0 pet	B-022
10. TRANS-ANETHOLE <small>DO NOT PRELOAD</small>	5.0 pet	A-015
11. SORBIC ACID	2.0 pet	S-003
12. BENZOIC ACID	5.0 pet	B-005
13. PROPIONIC ACID <small>DO NOT PRELOAD</small>	3.0 pet	P-018
14. Octyl gallate	0.25 pet	O-002
15. Hydroperoxides of Limonene <small>DO NOT PRELOAD</small>	0.3 pet	H-032A
16. AMMONIUM PERSULFATE	2.5 pet	A-011
17. Benzoylperoxide	1.0 pet	B-007
18. PROPYL GALLATE	1.0 pet	P-021
19. DODECYL GALLATE	0.25 pet	D-042
20. Gallate mix	1.0 pet	Mx-28B
-DODECYL GALLATE (D-042)	0.25	
-PROPYL GALLATE (P-021)	0.5	
-Octyl gallate (O-002)	0.25	

Revised January 2018

Corticosteroid Series

CS-1000

1. Budesonide ¹	0.01 pet	B-033B
2. Betamethasone-17-valerate	1.0 pet	B-031
3. Triamcinolone acetonide	1.0 pet	T-030
4. Tixocortol-21-pivalate ¹	0.1 pet	T-031B
5. Alclomethasone-17,21-dipropionate	1.0 pet	A-023

Compound	Conc. Veh. %(w/w)	Art. No.
6. Clobetasol-17-propionate	1.0 pet	C-028
7. Dexamethasone-21-phosphate disodium salt	1.0 pet	D-046
8. Hydrocortisone-17-butyrate <small>DO NOT PRELOAD</small>	1.0 alc	H-021A
9. Desoximetasone	1.0 pet	D-057
10. Betamethasone 17,21-dipropionate	1.0 pet	B-042
11. Methylprednisolone aceponate	1.0 pet	M-036
12. Corticosteroid mix	2.1% pet	Mx-23
-Budesonide (B-033)	0.1	
-Hydrocortisone-17-butyrate (H-021)	1.0	
-Tixocortol-21-pivalate (T-031)	1.0	
13. Hydrocortisone-21-acetate	1.0 pet	H-034

Revised January 2018

Cosmetic Series**C-1000**

1. ISOPROPYL MYRISTATE	20.0 pet	I-003
2. Amerchol L-101	50.0 pet	A-004
3. TRIETHANOLAMINE	2.0 pet	T-016
4. POLYSORBATE 80	5.0 pet	P-013
5. SORBITAN OLEATE	5.0 pet	S-004
6. 2-tert-Butyl-4-methoxyphenol (BHA)	2.0 pet	B-022
7. BHT	2.0 pet	D-006
8. Octyl gallate	0.25 pet	O-002
9. TRICLOSAN	2.0 pet	T-014
10. SORBIC ACID	2.0 pet	S-003
11. p-CHLORO-m-CRESOL (PCMC)	1.0 pet	C-008
12. CHLOROXYLENOL (PCMX)	0.5 pet	C-010A
13. THIMEROSAL	0.1 pet	T-007
14. IMIDAZOLIDINYL UREA	2.0 pet	I-001A
15. METHENAMINE	2.0 pet	H-003
16. CHLORHEXIDINE DIGLUCONATE <small>DO NOT PRELOAD</small>	0.5 aq	C-005
17. Paraben mix ¹	16.0 pet	Mx-03C
-BUTYLPARABEN (B-020)	4.0	
-ETHYLPARABEN (E-010)	4.0	
-METHYLPARABEN (M-012)	4.0	
-PROPYLPARABEN (P-020)	4.0	
18. PHENYL MERCURIC ACETATE <small>DO NOT PRELOAD</small>	0.01 aq	P-008
19. CHLOROACETAMIDE	0.2 pet	C-006
20. Hexahydro-1,3,5-tris-(2-hydroxyethyl)triazine <small>DO NOT PRELOAD</small>	1.0 aq	H-002

Compound	Conc. Veh. %(w/w)	Art. No.
21. Clioquinol	5.0 pet	C-015
22. Ethylenediamine dihydrochloride	1.0 pet	E-005
23. HYDROABIETYL ALCOHOL	10.0 pet	A-002
24. PHENYL SALICYLATE	1.0 pet	P-011
25. BENZOPHENONE-3	10.0 pet	H-014C
26. SORBITAN SESQUIOLEATE	20.0 pet	S-005
27. PROPYLENE GLYCOL ³ <small>DO NOT PRELOAD</small>	5.0 pet	P-019A
28. STEARYL ALCOHOL	30.0 pet	S-006
29. CETYL ALCOHOL	5.0 pet	C-003
30. BENZYL SALICYLATE	10.0 pet	B-010B
31. 2-BROMO-2-NITROPROPANE-1,3-DIOL	0.25 pet	B-015A
32. Sodium-2-pyridinethiol-1-oxide <small>DO NOT PRELOAD</small>	0.1 aq	S-002
33. COCAMIDOPROPYL BETAINE <small>DO NOT PRELOAD</small>	1.0 aq	C-018
34. BENZYL ALCOHOL <small>DO NOT PRELOAD</small>	10.0 sof	B-008B
35. METHYLISOTHIAZOLINONE + METHYLCHLOROISOTHIAZOLINONE ¹ <small>DO NOT PRELOAD</small>	0.02 aq	C-009B
36. t-BUTYL HYDROQUINONE	1.0 pet	B-028
37. DROMETRIZOLE	1.0 pet	H-016
38. PROPYL GALLATE	1.0 pet	P-021
39. DODECYL GALLATE	0.25 pet	D-042
40. QUATERNIUM-15 ¹	1.0 pet	C-007A
41. PHENOXYETHANOL <small>DO NOT PRELOAD</small>	1.0 pet	P-025
42. DIAZOLIDINYL UREA	2.0 pet	D-044A
43. TOCOPHEROL <small>DO NOT PRELOAD</small>	100	T-036
44. DMDM HYDANTOIN <small>DO NOT PRELOAD</small>	2.0 aq	D-047A
45. METHYLDIBROMO GLUTARONITRILE ¹	0.5 pet	D-049E
46. Tea tree oil oxidized <small>DO NOT PRELOAD</small>	5.0 pet	T-035B
47. IODOPROPYNYL BUTYL CARBAMATE	0.2 pet	I-008C
48. 3-(Dimethylamino)-1-propylamine <small>DO NOT PRELOAD</small>	1.0 aq	D-053
49. LAURYL POLYGLUCOSE <small>DO NOT PRELOAD</small>	3.0 pet	L-004
50. Peppermint oil <small>DO NOT PRELOAD</small>	2.0 pet	P-036
51. SHELLAC <small>DO NOT PRELOAD</small>	20.0 alc	S-015
52. TOCOPHERYL ACETATE	10.0 pet	T-037B
53. Turpentine oil oxidized <small>DO NOT PRELOAD</small>	0.4 pet	T-024B
54. METHYLISOTHIAZOLINONE ¹ <small>DO NOT PRELOAD</small>	0.2 aq	M-035B
55. Musk mix	3.0 pet	Mx-10B
-MUSK KETONE (M-018)	1.0	
-Musk moskene (M-019)	1.0	
-Musk xylene (M-021)	1.0	
56. OLEAMIDOPROPYL DIMETHYLAMINE <small>DO NOT PRELOAD</small>	0.1 aq	O-005
57. DECYL GLUCOSIDE ⁴ <small>DO NOT PRELOAD</small>	5.0 pet	D-065

Compound	Conc. % (w/w)	Veh.	Art. No.
58. ETHYLHEXYLGLYCERIN	5.0	pet	E-027
59. SODIUM METABISULFITE	1.0	pet	S-011
60. Gallate mix	1.0	pet	Mx-28B
-DODECYL GALLATE (D-042)	0.25		
-PROPYL GALLATE (P-021)	0.5		
-Octyl gallate (O-002)	0.25		
61. CETEARYL GLUCOSIDE	5.0	pet	C-056
62. PANTHENOL	5.0	pet	P-042
63. POLYAMINOPROPYL BIGUANIDE <small>DO NOT PRELOAD</small>	2.5	aq	P-043

Revised January 2020

Cutaneous Adverse Drug Reaction serie

CAD-1000

1. Cefixime trihydrate	10.0	pet	C-054
2. Amoxicillin trihydrate	10.0	pet	A-030
3. Dicloxacillin sodium salt hydrate	10.0	pet	D-058
4. Cefotaxim sodium salt	10.0	pet	C-040
5. Doxycycline monohydrate	10.0	pet	D-059
6. Cefpodoxime proxetil	10.0	pet	C-055
7. Erythromycin base	10.0	pet	E-024
8. Spiramycin base	10.0	pet	S-012
9. Clarithromycin	10.0	pet	C-041
10. Potassium clavulanate	10.0	pet	P-040
11. Cotrimoxazole	10.0	pet	C-042
12. Norfloxacin	10.0	pet	N-007
13. Ciprofloxacin hydrochloride	10.0	pet	C-043
14. Carbamazepine	1.0	pet	C-044
15. Hydantoin	10.0	pet	H-027
16. Diltiazem hydrochloride	10.0	pet	D-060
17. Captopril	5.0	pet	C-045
18. Acetylsalicylic acid	10.0	pet	A-031
19. Diclofenac sodium salt	5.0	pet	D-061B
20. Ketoprofen	1.0	pet	K-002B
21. Piroxicam	1.0	pet	P-033
22. ACETAMINOPHEN	10.0	pet	A-032
23. Acyclovir	10.0	pet	A-033
24. Hydroxyzine hydrochloride	1.0	pet	H-028
25. Hydrochlorothiazide	10.0	pet	H-029
26. Clindamycin phosphate	10.0	pet	C-046

Compound	Conc. % (w/w)	Veh.	Art. No.
27. Cefradine	10.0	pet	C-047
28. Cefalexin	10.0	pet	C-048
29. Ibuprofen	10.0	pet	I-010A
30. Lamotrigine	10.0	pet	L-009
31. Cefuroxime sodium	10.0	pet	C-053

Revised November 2021

Dental Screening

DS-1000

1. Methyl methacrylate <small>DO NOT PRELOAD</small>	2.0	pet	M-013
2. Triethylene glycol dimethacrylate	2.0	pet	T-018
3. Urethane dimethacrylate <small>DO NOT PRELOAD</small>	2.0	pet	U-004
4. Ethylene glycol dimethacrylate <small>DO NOT PRELOAD</small>	2.0	pet	E-007
5. Bisphenol A glycerolate dimethacrylate (BIS-GMA)	2.0	pet	H-013
6. N,N-dimethyl-4-toluidine <small>DO NOT PRELOAD</small>	5.0	pet	D-016
7. BENZOPHENONE-3	10.0	pet	H-014C
8. 1,4-Butanediol dimethacrylate <small>DO NOT PRELOAD</small>	2.0	pet	B-017
9. Bisphenol A dimethacrylate (BIS-MA) <small>DO NOT PRELOAD</small>	2.0	pet	M-007
10. Potassium dichromate ¹	0.5	pet	P-014A
11. Mercury <small>DO NOT PRELOAD</small>	0.5	pet	M-005
12. Cobalt(II)chloride hexahydrate ¹	1.0	pet	C-017A
13. 2-Hydroxyethyl methacrylate ¹ <small>DO NOT PRELOAD</small>	2.0	pet	H-010
14. Gold(I)sodium thiosulfate dihydrate	2.0	pet	G-005B
15. Nickel(II)sulfate hexahydrate ¹	5.0	pet	N-002A
16. EUGENOL <small>DO NOT PRELOAD</small>	2.0	pet	E-016
17. COLOPHONIUM ¹	20.0	pet	C-020
18. N-Ethyl-p-toluenesulfonamide	0.1	pet	E-015
19. FORMALDEHYDE ¹ <small>DO NOT PRELOAD</small>	2.0	aq	F-002B
20. 4-Tolyldiethanolamine	2.0	pet	T-011
21. Copper(II)sulfate pentahydrate	2.0	pet	C-022
22. Methylhydroquinone	1.0	pet	M-025
23. Palladium(II)chloride	2.0	pet	P-001
24. Aluminium(III)chloride hexahydrate	2.0	pet	A-022
25. BORNANEDIONE	1.0	pet	C-026
26. DIMETHYLAMINOETHYL METHACRYLATE <small>DO NOT PRELOAD</small>	0.2	pet	D-045
27. 1,6-Hexanediol diacrylate	0.1	pet	H-004
28. DROMETRIZOLE	1.0	pet	H-016
29. Tetrahydrofurfuryl methacrylate <small>DO NOT PRELOAD</small>	2.0	pet	T-027
30. Tin	50.0	pet	T-008

Compound	Conc. % (w/w)	Veh.	Art. No.
31. Sodium tetrachloropalladate(II) hydrate	3.0	pet	S-017
32. CARVONE	5.0	pet	C-035
33. 2,2-bis(4-(2-Methacryl-oxyethoxy)phenyl)-propane	2.0	pet	M-006B
34. GLUTARAL ² <small>DO NOT PRELOAD</small>	0.2	pet	G-003A

Revised January 2020

Dental Materials - Patients DMP-1000

1. Methyl methacrylate <small>DO NOT PRELOAD</small>	2.0	pet	M-013
2. Triethylene glycol dimethacrylate	2.0	pet	T-018
3. Ethylene glycol dimethacrylate <small>DO NOT PRELOAD</small>	2.0	pet	E-007
4. Bisphenol A glycerolate dimethacrylate (BIS-GMA)	2.0	pet	H-013
5. 2,2-bis(4-(2-Methacryl-oxyethoxy)phenyl)-propane (BIS-EMA)	2.0	pet	M-006B
6. 2-Hydroxyethyl methacrylate ¹ <small>DO NOT PRELOAD</small>	2.0	pet	H-010
7. DIMETHYLAMINOETHYL METHACRYLATE <small>DO NOT PRELOAD</small>	0.2	pet	D-045
8. Tetrahydrofurfuryl methacrylate <small>DO NOT PRELOAD</small>	2.0	pet	T-027
9. 1,4-Butanediol dimethacrylate <small>DO NOT PRELOAD</small>	2.0	pet	B-017
10. 1,6-Hexanediol diacrylate	0.1	pet	H-004
11. Potassium dichromate ¹	0.5	pet	P-014A
12. Mercury <small>DO NOT PRELOAD</small>	0.5	pet	M-005
13. Cobalt(II)chloride hexahydrate	1.0	pet	C-017A
14. Gold(I)sodium thiosulfate dihydrate	2.0	pet	G-005B
15. Nickel(II)sulfate hexahydrate ¹	5.0	pet	N-002A
16. EUGENOL <small>DO NOT PRELOAD</small>	2.0	pet	E-016
17. COLOPHONIUM ¹	20.0	pet	C-020
18. N-Ethyl-p-toluenesulfonamide	0.1	pet	E-015
19. Palladium(II)chloride	2.0	pet	P-001
20. CARVONE <small>DO NOT PRELOAD</small>	5.0	pet	C-035
21. DROMETRIZOLE	1.0	pet	H-016
22. Peru balsam ^{1,2} <small>DO NOT PRELOAD</small>	25.0	pet	B-001
23. Epoxy resin, Bisphenol A ¹	1.0	pet	E-002
24. Sodium tetrachloropalladate(II) hydrate	3.0	pet	S-017

Revised January 2021

Compound Conc. % (w/w) Art. No.

Dental Materials - Staff DMS-1000

1. Methyl methacrylate <small>DO NOT PRELOAD</small>	2.0	pet	M-013
2. Triethylene glycol dimethacrylate	2.0	pet	T-018
3. Ethyleneglycol dimethacrylate <small>DO NOT PRELOAD</small>	2.0	pet	E-007
4. Bisphenol A glycerolate dimethacrylate (BIS-GMA)	2.0	pet	H-013
5. 2-Hydroxyethyl methacrylate ¹ <small>DO NOT PRELOAD</small>	2.0	pet	H-010
6. Tetrahydrofurfuryl methacrylate <small>DO NOT PRELOAD</small>	2.0	pet	T-027
7. 1,4-Butanediol dimethacrylate <small>DO NOT PRELOAD</small>	2.0	pet	B-017
8. Mercury <small>DO NOT PRELOAD</small>	0.5	pet	M-005
9. EUGENOL <small>DO NOT PRELOAD</small>	2.0	pet	E-016
10. GLUTARAL ² <small>DO NOT PRELOAD</small>	0.2	pet	G-003A

Introduced 2005

Epoxy Series E-1000

1. METHENAMINE	2.0	pet	H-003
2. 4,4'-Diaminodiphenylmethane (MDA)	0.5	pet	D-001
3. Triethylenetetramine (TETA) <small>DO NOT PRELOAD</small>	0.5	pet	T-019
4. 2-Phenyl glycidyl ether <small>DO NOT PRELOAD</small>	0.25	pet	P-023
5. Diethylenetriamine, (DETA) <small>DO NOT PRELOAD</small>	1.0	pet	D-010
6. Isophorone diamine (IPD) <small>DO NOT PRELOAD</small>	0.1	pet	I-006
7. m-Xylylenediamine <small>DO NOT PRELOAD</small>	0.1	pet	X-001
8. Ethylenediamine dihydrochloride	1.0	pet	E-005
9. 3-(Dimethylamino)-1-propylamine <small>DO NOT PRELOAD</small>	1.0	aq	D-053
10. Epoxy resin, Bisphenol F	0.25	pet	B-035
11. 2,4,6-Tris(dimethylaminomethyl)phenol <small>DO NOT PRELOAD</small>	0.5	pet	T-048

Revised January 2021

European Photopatch Baseline Series EP-1000

1. BENZOPHENONE-3	10.0	pet	H-014C
2. BENZOPHENONE-4	2.0	pet	H-023C
3. 4-METHYLBENZYLIDENE CAMPHOR	10.0	pet	M-024B
4. ETHYLHEXYL METHOXYCINNAMATE	10.0	pet	E-019C
5. OCTOCRYLENE	10.0	pet	O-009
6. ISOAMYL p-METHOXYCINNAMATE	10.0	pet	I-009

Compound	Conc. Veh. %(w/w)	Art. No.
7. PABA	10.0 pet	A-006C
8. BUTYL METHOXYDIBENZOYLMETHANE	10.0 pet	B-029C
9. BIS-ETHYLHEXYLOXYPHENOL METHOXYPHENOL TRIAZINE	10.0 pet	B-037
10. DROMETRIZOLE TRISILOXANE	10.0 pet	D-055
11. Ketoprofen	1.0 pet	K-002B
12. 2-(4-Diethylamino-2-hydroxy benzoyl)- benzoic acid hexylester	10.0 pet	D-062
13. ETHYLHEXYL TRIAZONE	10.0 pet	O-010
14. Methylene bis-benzotriazolyl tetramethyl- butylphenol	10.0 pet	M-037
15. Etofenamate	2.0 pet	E-025
16. DIETHYLHEXYL BUTAMIDO TRIAZONE	10.0 pet	D-063
17. Piroxicam	1.0 pet	P-033
18. Benzydamine hydrochloride	2.0 pet	B-041
19. DECYL GLUCOSIDE ⁵ <small>DO NOT PRELOAD</small>	5.0 pet	D-065

Revised October 2021

European Photopatch Extended Series

EPE-1000

1. TRICLOCARBAN	1.0 pet	T-013
2. BENZOPHENONE-10	10.0 pet	H-020B
3. PHENYLBENZIMIDAZOLE SULFONIC ACID	10.0 pet	P-024B
4. HOMOSALATE	10.0 pet	H-024B
5. ETHYLHEXYL SALICYLATE	10.0 pet	O-007B
6. Polysilicone-15	10.0 pet	P-035
7. Disodium phenyl dibenzimidazole tetrasulfonate	10.0 pet	D-064
8. TRICLOSAN	2.0 pet	T-014
9. Ibuprofen	5.0 pet	I-010B
10. Diclofenac sodium salt	5.0 pet	D-061B
11. Fenofibrate	10.0 pet	F-006
12. Olaquinox	1.0 pet	O-008

Revised January 2021

Compound	Conc. Veh. %(w/w)	Art. No.
Fragrance Series		F-1000

1. CINNAMAL ^{EC} <small>DO NOT PRELOAD</small>	1.0 pet	C-014
2. CINNAMYL ALCOHOL ^{EC} <small>DO NOT PRELOAD</small>	2.0 pet	C-013
3. AMYL CINNAMAL ^{EC}	2.0 pet	A-014
4. EUGENOL ^{EC} <small>DO NOT PRELOAD</small>	2.0 pet	E-016
5. ISOEUGENOL ^{EC} <small>DO NOT PRELOAD</small>	2.0 pet	I-002
6. GERANIOL ^{EC} <small>DO NOT PRELOAD</small>	2.0 pet	G-001
7. Oakmoss absolute ^{EC,2} <small>DO NOT PRELOAD</small>	2.0 pet	O-001
8. HYDROXYCITRONELLAL ^{EC}	2.0 pet	H-008
9. Narcissus poeticus absolute <small>DO NOT PRELOAD</small>	2.0 pet	N-006
10. Musk xylene	1.0 pet	M-021
11. METHYL ANTHRANILATE	5.0 pet	M-028
12. Musk moskene	1.0 pet	M-019
13. SORBITAN SESQUIOLEATE	20.0 pet	S-005
14. Jasmine synthetic <small>DO NOT PRELOAD</small>	2.0 pet	J-001
15. BENZYL SALICYLATE ^{EC}	10.0 pet	B-010B
16. BENZYL ALCOHOL ^{EC} <small>DO NOT PRELOAD</small>	10.0 sof	B-008B
17. VANILLIN	10.0 pet	V-001
18. Lavender absolute <small>DO NOT PRELOAD</small>	2.0 pet	L-001
19. Cananga oil <small>DO NOT PRELOAD</small>	2.0 pet	C-002
20. Rose absolute <small>DO NOT PRELOAD</small>	2.0 pet	R-003
21. Ylang ylang oil <small>DO NOT PRELOAD</small>	2.0 pet	Y-001
22. Geranium oil <small>DO NOT PRELOAD</small>	2.0 pet	G-002
23. Jasmine absolute <small>DO NOT PRELOAD</small>	2.0 pet	J-002
24. Sandalwood oil <small>DO NOT PRELOAD</small>	2.0 pet	S-009
25. HYDROXYISOHEXYL 3-CYCLOHEXENE CARBOXALDEHYDE ^{EC,1}	5.0 pet	L-003
26. CITRAL ^{EC}	2.0 pet	C-036
27. FARNESOL ^{EC}	5.0 pet	F-004
28. CITRONELLOL ^{EC} <small>DO NOT PRELOAD</small>	1.0 pet	C-037
29. Hexyl cinnamic aldehyde ^{EC}	10.0 pet	H-025
30. COUMARIN ^{EC}	5.0 pet	C-038
31. Fragrance mix II ¹ <small>DO NOT PRELOAD</small>	14.0 pet	Mx-25
-Hexyl cinnamic aldehyde (H-025) ^{EC}	5.0	
-COUMARIN (C-038) ^{EC}	2.5	
-FARNESOL (F-004) ^{EC}	2.5	
-HYDROXYISOHEXYL 3-CYCLOHEXENE CARBOXALDEHYDE (L-003) ^{EC}	2.5	
-CITRAL (C-036) ^{EC}	1.0	
-CITRONELLOL (C-037) ^{EC} <small>DO NOT PRELOAD</small>	0.5	

Compound	Conc. Veh. %(w/w)	Art. No.
32. Amyl cinnamyl alcohol ^{EC}	5.0 pet	A-036
33. Anise alcohol ^{EC}	10.0 sof	A-037
34. BENZYL BENZOATE ^{EC}	10.0 pet	B-038
35. BENZYL CINNAMATE ^{EC}	10.0 pet	B-039
36. BUTYLPHENYL METHYLPROPIONAL ^{EC}	10.0 pet	B-040
37. Treemoss absolute ^{EC} <small>DO NOT PRELOAD</small>	1.0 pet	E-026
38. α-Isomethyl ionone ^{EC} <small>DO NOT PRELOAD</small>	10.0 pet	I-017
39. d-Limonene ^{EC} <small>DO NOT PRELOAD</small>	10.0 pet	L-006C
40. LINALOOL ^{EC} <small>DO NOT PRELOAD</small>	10.0 pet	L-005B
41. Methyl-2-octynoate ^{EC} <small>DO NOT PRELOAD</small>	0.2 pet	M-034
42. Majanthole	5.0 pet	M-033
43. Hydroperoxides of Linalool <small>DO NOT PRELOAD</small>	1.0 pet	H-031A
44. Hydroperoxides of Limonene <small>DO NOT PRELOAD</small>	0.3 pet	H-032A
45. Fragrance mix I ^{1,2} <small>DO NOT PRELOAD</small>	8.0 pet	Mx-07
-AMYL CINNAMAL (A-014)	1.0	
-CINNAMYL ALCOHOL (C-013) <small>DO NOT PRELOAD</small>	1.0	
-CINNAMAL (C-014) <small>DO NOT PRELOAD</small>	1.0	
-EUGENOL (E-016) <small>DO NOT PRELOAD</small>	1.0	
-GERANIOL (G-001) <small>DO NOT PRELOAD</small>	1.0	
-HYDROXYCITRONELLAL (H-008)	1.0	
-ISOEUGENOL (I-002) <small>DO NOT PRELOAD</small>	1.0	
-Oakmoss absolute (O-001) <small>DO NOT PRELOAD</small>	1.0	
46. Hydroperoxides of Linalool <small>DO NOT PRELOAD</small>	0.5 pet	H-031B
47. Hydroperoxides of Limonene <small>DO NOT PRELOAD</small>	0.2 pet	H-032B
48. Styrax <small>DO NOT PRELOAD</small>	2.0 pet	S-008

Revised January 2017

Hairdressing Series

H-1000

1. p-PHENYLENEDIAMINE (PPD) ¹	1.0 pet	P-006
2. TOLUENE-2,5-DIAMINE SULFATE	1.0 pet	D-002
3. 2-NITRO-p-PHENYLENEDIAMINE	1.0 pet	N-004
4. AMMONIUM THIOGLYCOLATE <small>DO NOT PRELOAD</small>	2.5 aq	A-012
5. AMMONIUM PERSULFATE	2.5 pet	A-011
6. FORMALDEHYDE ¹ <small>DO NOT PRELOAD</small>	2.0 aq	F-002B
7. Nickel(II)sulfate hexahydrate ¹	5.0 pet	N-002A
8. Cobalt(II)chloride hexahydrate ¹	1.0 pet	C-017A
9. RESORCINOL	1.0 pet	R-001
10. m-AMINOPHENOL	1.0 pet	A-008
11. p-AMINOPHENOL	1.0 pet	A-009

Compound	Conc. Veh. %(w/w)	Art. No.
12. Deleted 2020		
13. HYDROQUINONE	1.0 pet	H-007
14. Peru balsam ^{1,2} <small>DO NOT PRELOAD</small>	25.0 pet	B-001
15. CHLOROACETAMIDE	0.2 pet	C-006
16. GLYCERYL THIOGLYCOLATE <small>DO NOT PRELOAD</small>	1.0 pet	G-004
17. COCAMIDOPROPYL BETAINE <small>DO NOT PRELOAD</small>	1.0 aq	C-018
18. METHYLISOTHIAZOLINONE + METHYLCHLORO-ISOTHIAZOLINONE ¹ <small>DO NOT PRELOAD</small>	0.02 aq	C-009B
19. 2-BROMO-2-NITROPROPANE-1,3-DIOL	0.25 pet	B-015A
20. Captan	0.5 pet	C-025
21. p-CHLORO-m-CRESOL (PCMC)	1.0 pet	C-008
22. CHLOROXYLENOL (PCMX)	0.5 pet	C-010A
23. IMIDAZOLIDINYL UREA	2.0 pet	I-001A
24. QUATERNIUM-15 ¹	1.0 pet	C-007A
25. ZINC PYRITHIONE	1.0 pet	Z-006
26. DIAZOLIDINYL UREA	2.0 pet	D-044A
27. LAURYL POLYGLUCOSE <small>DO NOT PRELOAD</small>	3.0 pet	L-004
28. OLEAMIDOPROPYL DIMETHYLAMINE <small>DO NOT PRELOAD</small>	0.1 aq	O-005
29. DECYL GLUCOSIDE ⁴ <small>DO NOT PRELOAD</small>	5.0 pet	D-065
30. TOLUENE-2,5-DIAMINE	1.0 pet	T-049
31. 4-AMINO-2-HYDROXYTOLUENE	1.0 pet	A-039
32. CYSTEAMINE HCL	0.5 pet	C-052
33. 2-METHYLRESORCINOL	1.0 pet	M-039
34. HYDROXYETHYL-p-PHENYLENE- DIAMINE SULFATE	2.0 pet	H-033
35. p-METHYLAMINOPHENOL	1.0 pet	M-040
36. CETRIMONIUM BROMIDE	0.5 pet	C-050
37. SODIUM METABISULFITE	1.0 pet	S-011
38. PANTHENOL	5.0 pet	P-042

Revised December 2019

Implant Series

IMP-1000

1. Vancomycin hydrochloride <small>DO NOT PRELOAD</small>	10.0 aq	V-004
2. Tobramycin	20.0 pet	T-050
3. Benzoylperoxide	1.0 pet	B-007
4. HYDROQUINONE	1.0 pet	H-007
5. N,N-dimethyl-4-toluidine <small>DO NOT PRELOAD</small>	5.0 pet	D-016
6. ETHYL CYANOACRYLATE <small>DO NOT PRELOAD</small>	10.0 pet	E-023
7. Aluminium(III)chloride hexahydrate	2.0 pet	A-022

Compound	Conc. Veh. %(w/w)	Art. No.
8. Cobalt(II)chloride hexahydrate ¹	1.0 pet	C-017A
9. Beryllium(II)sulfate tetrahydrate	1.0 pet	B-044
10. Gold(I)sodium thiosulfate dihydrate	2.0 pet	G-005B
11. Copper(II)sulfate pentahydrate	2.0 pet	C-022
12. Tin	50.0 pet	T-008
13. Iridium(III)chloride trihydrate	1.0 pet	I-012
14. Titanium(III)nitride	5.0 pet	T-039
15. Mercury	0.5 pet	M-005
16. ZINC CHLORIDE	1.0 pet	Z-007B
17. Titanium(IV)oxalate hydrate	5.0 pet	T-041
18. Sodium tetrachloropalladate(II) hydrate	3.0 pet	S-017
19. Molybdenum	5.0 pet	M-030
20. Vanadium(III)chloride	1.0 pet	V-003
21. MANGANESE CHLORIDE	2.0 pet	M-031
22. Zirconium(IV)chloride	1.0 pet	Z-008
23. Tungsten	5.0 pet	T-043
24. FERRIC CHLORIDE	2.0 pet	I-016
25. Ammonium tetrachloroplatinate(II) <small>DO NOT PRELOAD</small>	0.25 aq	A-013
26. Cadmium chloride <small>DO NOT PRELOAD</small>	1.0 aq	C-001
27. Indium(III)chloride <small>DO NOT PRELOAD</small>	10.0 aq	I-011
28. Nickel(II)sulfate hexahydrate ¹	5.0 pet	N-002A
29. Rhodium(III)chloride hydrate	2.0 pet	R-013
30. Gallium(III)oxide	1.0 pet	G-007
31. Ruthenium	0.1 pet	R-012
32. SILVER NITRATE <small>DO NOT PRELOAD</small>	1.0 aq	S-007
33. ALUMINUM HYDROXIDE	10.0 pet	A-038
34. Niobium(V)chloride	0.2 pet	N-008
35. Tantalum	1.0 pet	T-047
36. Potassium dichromate	0.5 pet	P-014A
37. Gentamicin sulfate	20.0 pet	G-006
38. Neomycin sulfate	20.0 pet	N-001
39. Bacitracin	20.0 pet	B-032B
40. 2-Hydroxyethyl methacrylate ¹ <small>DO NOT PRELOAD</small>	2.0 pet	H-010
41. Methyl methacrylate <small>DO NOT PRELOAD</small>	2.0 pet	M-013
42. CHLORHEXIDINE DIGLUCONATE <small>DO NOT PRELOAD</small>	0.5 aq	C-005
43. Ethyl acrylate <small>DO NOT PRELOAD</small>	0.1 pet	E-004
44. CALCIUM TITANATE	10.0 pet	C-049

Revised January 2022

Compound	Conc. Veh. %(w/w)	Art. No.
Isocyanate Series		I-1000
1. Toluene-2,4-diisocyanate (TDI) <small>DO NOT PRELOAD</small>	2.0 pet	T-009
2. Diphenylmethane-4,4'-diisocyanate (MDI) <small>DO NOT PRELOAD</small>	0.5 pet	D-023B
3. 4,4'-Diaminodiphenylmethane (MDA)	0.5 pet	D-001
4. ISOPHORONE DIISOCYANATE (IPDI) <small>DO NOT PRELOAD</small>	1.0 pet	I-007
5. Isophorone diamine (IPD) <small>DO NOT PRELOAD</small>	0.1 pet	I-006
6. Hexamethylene diisocyanate (HDI) <small>DO NOT PRELOAD</small>	0.1 pet	H-022
7. Polymeric diphenylmethane diisocyanate (PMDI) <small>DO NOT PRELOAD</small>	2.0 pet	P-038

Revised March 2013

Compound	Conc. Veh. %(w/w)	Art. No.
Leg Ulcer Series		LU-1000
1. Amerchol L-101	50.0 pet	A-004
2. Fusidic acid sodium salt	2.0 pet	F-003
3. CHLORHEXIDINE DIGLUCONATE <small>DO NOT PRELOAD</small>	0.5 aq	C-005
4. BENZALKONIUM CHLORIDE <small>DO NOT PRELOAD</small>	0.1 aq	B-027
5. Nitrofurazone	1.0 pet	N-005
6. Bacitracin	5.0 pet	B-032A
7. CETEARYL ALCOHOL	20.0 pet	C-033
8. BHT	2.0 pet	D-006
9. Chloramphenicol	5.0 pet	C-032
10. Benzoylperoxide	1.0 pet	B-007
11. PROPYLENE GLYCOL <small>DO NOT PRELOAD</small>	5.0 pet	P-019A
12. Propolis ¹	10.0 pet	P-022
13. THIMEROSAL	0.1 pet	T-007
14. SORBIC ACID	2.0 pet	S-003
15. Eosin	5.0 pet	E-022
16. p-CHLORO-m-CRESOL (PCMC)	1.0 pet	C-008
17. Budesonide ¹	0.01 pet	B-033B
18. TRIETHANOLAMINE	2.0 pet	T-016
19. Framycetin sulphate	20.0 pet	F-005
20. SORBITAN SESQUIOLEATE	20.0 pet	S-005
21. Tixocortol-21-pivalate ¹	0.1 pet	T-031B
22. SORBITAN OLEATE	5.0 pet	S-004
23. PHENYL MERCURIC ACETATE <small>DO NOT PRELOAD</small>	0.01 aq	P-008
24. CHLOROACETAMIDE	0.2 pet	C-006
25. DIAZOLIDINYL UREA	2.0 pet	D-044A
26. IMIDAZOLIDINYL UREA	2.0 pet	I-001A

Compound	Conc. Veh. %(w/w)	Art. No.
27. Wood tar mix <small>DO NOT PRELOAD</small>	12.0 pet	Mx-14
-Beech tar (B-002) <small>DO NOT PRELOAD</small>	3.0	
-Birch tar (B-011) <small>DO NOT PRELOAD</small>	3.0	
-Juniperus oxycedrus extract (J-003) <small>DO NOT PRELOAD</small>	3.0	
-Pine tar (P-012) <small>DO NOT PRELOAD</small>	3.0	

Revised January 2007

Medicament Series ME-1000

1. Chloramphenicol	5.0 pet	C-032
2. Kanamycin sulfate	10.0 pet	K-001
3. Quinine sulfate	1.0 pet	Q-001
4. Sulfanilamide	5.0 pet	S-010
5. Gentamicin sulfate	20.0 pet	G-006
6. Nitrofurazone	1.0 pet	N-005
7. Bacitracin	5.0 pet	B-032A
8. Framycetin sulphate	20.0 pet	F-005
9. Caine mix III ¹	10.0 pet	Mx-19
-Benzocaine (B-004)	5.0	
-Dibucaine hydrochloride (D-005)	2.5	
-Tetracaine hydrochloride (T-025)	2.5	
10. Miconazole <small>DO NOT PRELOAD</small>	1.0 alc	M-027
11. Econazole nitrate <small>DO NOT PRELOAD</small>	1.0 alc	E-021
12. Caine mix IV	10.0 pet	Mx-20
-Lidocaine (L-002)	5.0	
-Amylocaine hydrochloride (A-020)	2.5	
-Prilocaine hydrochloride (P-027)	2.5	
13. Fusidic acid sodium salt	2.0 pet	F-003
14. Tioconazole	1.0 pet	T-034
15. Tobramycin	20.0 pet	T-050
16. Vancomycin hydrochloride <small>DO NOT PRELOAD</small>	10.0 aq	V-004
17. Bufexamac	5.0 pet	B-043
18. Pramoxine hydrochloride	2.0 pet	P-039
19. Phenylbutazone	10.0 pet	P-041
20. Diphenhydramine hydrochloride	1.0 pet	D-021
21. Polymyxin B sulfate	5.0 pet	P-026

Revised January 2018

Compound Conc. Veh. Art. No.

Metal Series MET-1000

1. Aluminium(III)chloride hexahydrate	2.0 pet	A-022
2. Cobalt(II)chloride hexahydrate ¹	1.0 pet	C-017A
3. Beryllium(II)sulfate tetrahydrate	1.0 pet	B-044
4. Gold(I)sodium thiosulfate dihydrate	2.0 pet	G-005B
5. Copper(II)sulfate pentahydrate	2.0 pet	C-022
6. Tin	50.0 pet	T-008
7. Iridium(III)chloride trihydrate	1.0 pet	I-012
8. Titanium(III)nitride	5.0 pet	T-039
9. Mercury	0.5 pet	M-005
10. ZINC CHLORIDE	1.0 pet	Z-007B
11. Titanium(IV)oxalate hydrate	5.0 pet	T-041
12. Sodium tetrachloropalladate(II) hydrate	3.0 pet	S-017
13. Molybdenum	5.0 pet	M-030
14. Vanadium(III)chloride	1.0 pet	V-003
15. MANGANESE CHLORIDE	2.0 pet	M-031
16. Zirconium(IV)chloride	1.0 pet	Z-008
17. Tungsten	5.0 pet	T-043
18. FERRIC CHLORIDE	2.0 pet	I-016
19. Ammonium tetrachloroplatinate(II) <small>DO NOT PRELOAD</small>	0.25 aq	A-013
20. Cadmium chloride <small>DO NOT PRELOAD</small>	1.0 aq	C-001
21. Indium(III)chloride <small>DO NOT PRELOAD</small>	10.0 aq	I-011
22. Nickel(II)sulfate hexahydrate ¹	5.0 pet	N-002A
23. Rhodium(III)chloride hydrate	2.0 pet	R-013
24. Gallium(III)oxide	1.0 pet	G-007
25. Ruthenium	0.1 pet	R-012
26. SILVER NITRATE <small>DO NOT PRELOAD</small>	1.0 aq	S-007
27. ALUMINUM HYDROXIDE	10.0 pet	A-038
28. Niobium(V)chloride	0.2 pet	N-008
29. Tantalum	1.0 pet	T-047
30. Potassium dichromate	0.5 pet	P-014A

Revised January 2022

Compound	Conc. % (w/w)	Veh.	Art. No.
Metal Series Extended			
MEIE-1000			
1. Zinc	2.5	pet	Z-001
2. Potassium dicyanoaurate(I)	0.1	aq	P-015
3. Mercury(II)chloride	0.1	pet	M-004
4. Mercury(II)amidochloride	1.0	pet	M-022
5. Gold(I)sodium thiosulfate dihydrate	0.5	pet	G-005A
6. Copper(I)oxide	5.0	pet	C-021
7. Iridium	1.0	pet	I-014
8. Indium	1.0	pet	I-015
9. CALCIUM TITANATE	10.0	pet	C-049
10. Vanadium	5.0	pet	V-002
11. Tin(II)oxalate	1.0	pet	S-014
12. PHENYL MERCURIC ACETATE	0.01	aq	P-008
13. Ammonium molybdate (VI) tetrahydrate	1.0	aq	A-035
14. Ammonium hexachloroiridate(IV)	0.1	aq	A-034
15. Indium(III)sulfate	10.0	aq	I-013
16. STANNOUS CHLORIDE	1.0	pet	S-013
17. Lead(II)chloride	0.2	aq	L-008
18. Ammonium hexachloroplatinate(IV)	0.1	aq	A-010
19. Palladium(II)chloride	2.0	pet	P-001
20. TITANIUM DIOXIDE	10.0	pet	T-040
21. Molybdenum(V)chloride	0.5	pet	M-038
22. Titanium	10.0	pet	T-042
23. Sodium tungstate dihydrate	2.0	aq	S-019
24. Vanadium(V)oxide	10.0	pet	V-005
25. ZIRCONIUM DIOXIDE	0.1	pet	Z-009

Revised January 2022

26. (Meth) Acrylate Series

Adhesives, Dental, Printing & Other

MA-1000

1. Methyl methacrylate	2.0	pet	M-013
2. BUTYL METHACRYLATE	2.0	pet	B-021
3. 2-Hydroxyethyl methacrylate ¹	2.0	pet	H-010
4. Hydroxypropyl methacrylate	2.0	pet	H-018
5. Ethylene glycol dimethacrylate	2.0	pet	E-007
6. Triethylene glycol dimethacrylate	2.0	pet	T-018
7. 1,4-Butanediol dimethacrylate	2.0	pet	B-017
8. Urethane dimethacrylate	2.0	pet	U-004

Compound	Conc. % (w/w)	Veh.	Art. No.
9. Bisphenol A dimethacrylate (BIS-MA)	2.0	pet	M-007
10. Bisphenol A glycerolate dimethacrylate (BIS-GMA)	2.0	pet	H-013
11. 1,6-Hexanediol diacrylate	0.1	pet	H-004
12. Tetrahydrofurfuryl methacrylate	2.0	pet	T-027
13. Tetraethylene glycol dimethacrylate	2.0	pet	T-029
14. DIMETHYLAMINOETHYL METHACRYLATE	0.2	pet	D-045
15. ETHYL CYANOACRYLATE	10.0	pet	E-023
16. ISOBORNYL ACRYLATE	0.1	pet	I-019
17. Ethyl acrylate	0.1	pet	E-004
18. 2-Hydroxyethyl acrylate	0.1	pet	H-009
19. ETHYL METHACRYLATE	2.0	pet	E-012
20. 2,2-bis(4-(2-Methacryloxyethoxy)phenyl)propane (BIS-EMA)	2.0	pet	M-006B
21. 1,4-Butanediol diacrylate	0.1	pet	B-016
22. Di(ethylene glycol) diacrylate	0.1	pet	D-009
23. Tri(propylene glycol) diacrylate	0.1	pet	T-023
24. Trimethylolpropane triacrylate	0.1	pet	T-021
25. Triethylene glycol diacrylate	0.1	pet	T-017
26. N,N-Methylene-bisacrylamide	1.0	pet	M-023
27. Butyl acrylate	0.1	pet	B-018

Revised January 2022

(Meth) Acrylate Series

Nails-Artificial

MN-1000

1. ETHYL CYANOACRYLATE	10.0	pet	E-023
2. ETHYL METHACRYLATE	2.0	pet	E-012
3. Methyl methacrylate	2.0	pet	M-013
4. 2-Hydroxyethyl methacrylate ¹	2.0	pet	H-010
5. Hydroxypropyl methacrylate	2.0	pet	H-018
6. Ethylene glycol dimethacrylate	2.0	pet	E-007
7. Bisphenol A glycerolate dimethacrylate (BIS-GMA)	2.0	pet	H-013
8. 1,6-Hexanediol diacrylate	0.1	pet	H-004
9. Triethylene glycol diacrylate	0.1	pet	T-017
10. Tetrahydrofurfuryl methacrylate	2.0	pet	T-027
11. Ethyl acrylate	0.1	pet	E-004
12. 2-Hydroxyethyl acrylate	0.1	pet	H-009

Revised August 1992

Compound	Conc. Veh. %(w/w)	Art. No.
(Meth) Acrylate Series		
Printing		MP-1000

Deleted January 2022

Oil & Cooling Fluid Series O-1000

1. ABIETIC ACID	10.0	pet	A-001
2. p-CHLORO-m-CRESOL (PCMC)	1.0	pet	C-008
3. CHLOROXYLENOL (PCMX)	0.5	pet	C-010A
4. DICHLOROPHENE	1.0	pet	D-008
5. o-PHENYLPHENOL	1.0	pet	P-010
6. PROPYLENE GLYCOL <small>DO NOT PRELOAD</small>	5.0	pet	P-019A
7. TRIETHANOLAMINE	2.0	pet	T-016
8. 4-tert-Butylbenzoic acid	1.0	pet	B-019
9. BENZISOTHIAZOLINONE	0.1	pet	B-003B
10. Hexahydro-1,3,5-tris-(2-hydroxyethyl)triazine <small>DO NOT PRELOAD</small>	1.0	aq	H-002
11. Bioban P 1487 <small>DO NOT PRELOAD</small>	0.5	pet	E-014
12. CHLOROACETAMIDE	0.2	pet	C-006
13. N-Methylolchloroacetamide	0.1	pet	M-014
14. BENZOTRIAZOLE	1.0	pet	B-006
15. Ethylenediamine dihydrochloride	1.0	pet	E-005
16. 2-Mercaptobenzothiazole (MBT) ¹	2.0	pet	M-003A
17. Zinc ethylenebis-(dithiocarbamate) (Zineb)	1.0	pet	Z-005
18. TRICLOSAN	2.0	pet	T-014
19. 7-ETHYLBICYCLOOXAZOLIDINE <small>DO NOT PRELOAD</small>	1.0	pet	A-017
20. Bioban CS 1135 <small>DO NOT PRELOAD</small>	1.0	pet	D-015
21. TRIS(HYDROXYMETHYL)NITROMETHANE	1.0	pet	H-015
22. THIMEROSAL	0.1	pet	T-007
23. Hydrazine sulfate	1.0	pet	H-005
24. TRICLOCARBAN	1.0	pet	T-013
25. FORMALDEHYDE ¹ <small>DO NOT PRELOAD</small>	2.0	aq	F-002B
26. Amerchol L-101	50.0	pet	A-004
27. Hydroperoxides of Limonene <small>DO NOT PRELOAD</small>	0.3	pet	H-032A
28. Sodium-2-pyridinethiol-1-oxide <small>DO NOT PRELOAD</small>	0.1	aq	S-002
29. 2-BROMO-2-NITROPROPANE-1,3-DIOL	0.25	pet	B-015A
30. COCAMIDE DEA	0.5	pet	C-019
31. METHYLISOTHIAZOLINONE + METHYLCHLORO-ISOTHIAZOLINONE ¹ <small>DO NOT PRELOAD</small>	0.02	aq	C-009B

Compound	Conc. Veh. %(w/w)	Art. No.	
32. PHENOXYETHANOL <small>DO NOT PRELOAD</small>	1.0	pet	P-025
33. 2-n-Octyl-4-isothiazolin-3-one <small>DO NOT PRELOAD</small>	0.1	pet	O-004
34. METHYLDIBROMO GLUTARONITRILE ¹	0.5	pet	D-049E
35. IODOPROPYNYL BUTYL CARBAMATE	0.2	pet	I-008C

Revised January 2014

Plant Series PL-1000

1. Anthemis nobilis extract <small>DO NOT PRELOAD</small>	1.0	pet	C-029
2. Diallyl disulfide <small>DO NOT PRELOAD</small>	1.0	pet	D-048
3. Arnica montana extract <small>DO NOT PRELOAD</small>	0.5	pet	A-024
4. Taraxacum officinale extract <small>DO NOT PRELOAD</small>	2.5	pet	T-032
5. Achillea millefolium extract <small>DO NOT PRELOAD</small>	1.0	pet	A-025
6. Propolis ¹	10.0	pet	P-022
7. Chrysanthemum Cinerariaefolium extract <small>DO NOT PRELOAD</small>	1.0	pet	C-031
8. Sesquiterpene lactone mix ¹	0.1	pet	Mx-18
-Alantolactone (A-003)	0.033		
-Costunolide (C-039)	0.033		
-Dehydrocostus lactone (D-056)	0.033		
9. α-Methylene-γ-butyrolactone <small>DO NOT PRELOAD</small>	0.01	pet	M-026
10. Tanacetum vulgare extract <small>DO NOT PRELOAD</small>	1.0	pet	T-033
11. Alantolactone	0.033	pet	A-003B
12. Lichen acid mix	0.3	pet	Mx-15
-Atranorin (A-016)	0.1		
-Evernic acid (E-017)	0.1		
-(+)-Usnic acid (U-005)	0.1		
13. Parthenolide	0.1	pet	P-029
14. Chamomilla recutita extract <small>DO NOT PRELOAD</small>	1.0	pet	C-051
15. (+)-Usnic acid	0.1	pet	U-005
16. Atranorin	0.1	pet	A-016
17. Evernic acid	0.1	pet	E-017
18. 2-Methoxy-6-n-pentyl-4-benzoquinone	0.01	pet	M-008

Revised November 2018

Compound	Conc. % (w/w)	Veh.	Art. No.
Plastics & Glues Series			
PG-1000			
1. HYDROQUINONE	1.0	pet	H-007
2. Dibutyl phthalate	5.0	pet	D-007
3. PHENYL SALICYLATE	1.0	pet	P-011
4. Dioctyl phthalate (DEHP, DOP)	2.0	pet	D-018
5. BHT	2.0	pet	D-006
6. DROMETRIZOLE	1.0	pet	H-016
7. Benzoylperoxide	1.0	pet	B-007
8. 4-tert-Butylcatechol (PTBC)	0.25	pet	B-030B
9. Triglycidyl isocyanurate (TGIC)	0.5	pet	T-028
10. Bisphenol A	1.0	pet	B-013
11. Tricresyl phosphate	5.0	pet	T-015
12. Phenol formaldehyde resin (PFR2) <small>DO NOT PRELOAD</small>	1.0	pet	P-005
13. p-tert-Butylphenol formaldehyde resin ¹	1.0	pet	B-024
14. Triphenyl phosphate	5.0	pet	T-022
15. Toluenesulfonamide formaldehyde resin	10.0	pet	T-010
16. Resorcinol monobenzoate	1.0	pet	R-002
17. 2-Phenylindole	2.0	pet	P-007
18. 2-tert-Butyl-4-methoxyphenol (BHA)	2.0	pet	B-022
19. HYDROABIETYL ALCOHOL	10.0	pet	A-002
20. 4-tert-Butylphenol	1.0	pet	B-023
21. 2-Monomethylol phenol	1.0	pet	M-015
22. N,N'-Diphenylthiourea (DPTU)	1.0	pet	D-025
23. 2-n-Octyl-4-isothiazolin-3-one <small>DO NOT PRELOAD</small>	0.1	pet	O-004

Revised January 2020

Compound	Conc. % (w/w)	Veh.	Art. No.
Rubber Additives Series			
R-1000			
1. Tetramethylthiuram disulfide (TMTD)	1.0	pet	T-005
2. Tetramethylthiuram monosulfide (TMTM)	1.0	pet	T-006
3. Tetraethylthiuram disulfide (TETD)	1.0	pet	T-002
4. Dipentamethylenethiuram disulfide	1.0	pet	D-019
5. N-Cyclohexyl-N-phenyl-4-phenylenediamine	1.0	pet	C-024
6. N,N'-Diphenyl-p-phenylenediamine (DPPD)	1.0	pet	D-024
7. N-Isopropyl-N-phenyl-4-phenylenediamine (IPPD) ¹	0.1	pet	I-004
8. 2-Mercaptobenzothiazole (MBT) ¹	2.0	pet	M-003A
9. N-Cyclohexyl-2-benzothiazolylsulfenamide	1.0	pet	C-023
10. Dibenzothiazyl disulfide (MBTS)	1.0	pet	D-003

Compound	Conc. % (w/w)	Veh.	Art. No.
11. 2-(4-Morpholinylmercapto)benzothiazol (MOR)	1.0	pet	M-016
12. 1,3-Diphenylguanidine	1.0	pet	D-022
13. Zinc diethyldithiocarbama (ZDC)	1.0	pet	Z-003
14. ZINC DIBUTYLDITHIOCARBAMATE (ZBC)	1.0	pet	Z-002
15. N,N-Di-2-naphtyl-4-phenylenediamine (DBNPD)	1.0	pet	D-017
16. N-Phenyl-2-naphtylamine (PBN)	1.0	pet	P-009
17. METHENAMINE	2.0	pet	H-003
18. 4,4'-Diaminodiphenylmethane (MDA)	0.5	pet	D-001
19. N,N'-Diphenylthiourea (DPTU)	1.0	pet	D-025
20. Zinc dimethyldithiocarbamate (Ziram)	1.0	pet	Z-004
21. 2,2,4-Trimethyl-1,2-dihydroquinoline	1.0	pet	T-020
22. N,N'-Diethylthiourea	1.0	pet	D-039
23. N,N'-Dibutylthiourea	1.0	pet	D-038
24. Dodecyl mercaptan <small>DO NOT PRELOAD</small>	0.1	pet	D-043
25. N-(Cyclohexylthio) phthalimide	1.0	pet	C-034
26. Thiourea	0.1	pet	T-026
27. 4,4'-Dithiodimorpholine	1.0	pet	D-054

Revised November 2018

Compound	Conc. % (w/w)	Veh.	Art. No.
Shoe Series			
SH-1000			
1. N-Isopropyl-N-phenyl-4-phenylenediamine (IPPD) ¹	0.1	pet	I-004
2. GLUTARAL ² <small>DO NOT PRELOAD</small>	0.2	pet	G-003A
3. DISPERSE ORANGE 3	1.0	pet	D-032
4. Acid yellow 36	1.0	pet	A-019
5. Hydroquinone monobenzylether	1.0	pet	H-019
6. Thiuram mix ¹	1.0	pet	Mx-01
-Dipentamethylenethiuram disulfide (D-019)	0.25		
-Tetraethylthiuram disulfide (TETD) (T-002)	0.25		
-Tetramethylthiuram disulfide (TMTD) (T-005)	0.25		
-Tetramethylthiuram monosulfide (TMTM) (T-006)	0.25		
7. Potassium dichromate ¹	0.5	pet	P-014A
8. 4-tert-Butylphenolformaldehyde resin (PTBP) ¹	1.0	pet	B-024
9. p-PHENYLENEDIAMINE (PPD) ¹	1.0	pet	P-006
10. Nickel(II)sulfate hexahydrate ¹	5.0	pet	N-002A
11. COLOPHONIUM ¹	20.0	pet	C-020
12. FORMALDEHYDE ¹ <small>DO NOT PRELOAD</small>	2.0	aq	F-002B
13. N,N'-Diphenylthiourea (DPTU)	1.0	pet	D-025
14. 2-Mercaptobenzothiazole (MBT) ¹	2.0	pet	M-003A ₉

Compound	Conc. Veh. %(w/w)	Art. No.
15. N,N'-Diethylthiourea	1.0 pet	D-039
16. 1,3-Diphenylguanidine	1.0 pet	D-022
17. N,N'-Dibutylthiourea	1.0 pet	D-038
18. Epoxy resin, Bisphenol A ¹	1.0 pet	E-002
19. Dodecyl mercaptan <small>DO NOT PRELOAD</small>	0.1 pet	D-043
20. METHYLISOTHIAZOLINONE + METHYLCHLORO-ISOTHIAZOLINONE ¹ <small>DO NOT PRELOAD</small>	0.02 aq	C-009B
21. 4-Aminoazobenzene	0.25 pet	A-005
22. 2-n-Octyl-4-isothiazolin-3-one <small>DO NOT PRELOAD</small>	0.1 pet	O-004
23. 4,4'-Dithiodimorpholine	1.0 pet	D-054
24. Dimethyl fumarate <small>DO NOT PRELOAD</small>	0.01 pet	D-066B

Revised November 2018

Sunscreen Series SU-1000

1. BUTYL METHOXYDIBENZOYL-METHANE	10.0 pet	B-029C
2. PABA	10.0 pet	A-006C
3. HOMOSALATE	5.0 pet	H-024A
4. 4-METHYLBENZYLIDENE CAMPHOR	10.0 pet	M-024B
5. ETHYLHEXYL DIMETHYL PABA	10.0 pet	E-018D
6. BENZOPHENONE-3	10.0 pet	H-014C
7. ETHYLHEXYL METHOXYCINNAMATE	10.0 pet	E-019C
8. BENZOPHENONE-10	10.0 pet	H-020B
9. PHENYLBENZIMIDAZOLE SULFONIC ACID	10.0 pet	P-024B
10. BENZOPHENONE-4	2.0 pet	H-023C
11. DROMETRIZOLE TRISILOXANE	10.0 pet	D-055
12. OCTOCRYLENE	10.0 pet	O-009
13. ETHYLHEXYL SALICYLATE	5.0 pet	O-007A
14. ETHYLHEXYL TRIAZONE	10.0 pet	O-010
15. ISOAMYL p-METHOXYCINNAMATE	10.0 pet	I-009
16. BIS-ETHYLHEXYLOXYPHENOL METHOXYPHENOL TRIAZINE	10.0 pet	B-037
17. Methylene bis-benzotriazolyl tetramethylbutylphenol	10.0 pet	M-037
18. 2-(4-Diethylamino-2-hydroxybenzoyl)-benzoic acid hexylester	10.0 pet	D-062
19. DIETHYLHEXYL BUTAMIDO TRIAZONE	10.0 pet	D-063
20. Disodium phenyl dibenzimidazole	10.0 pet	D-064

Compound	Conc. Veh. %(w/w)	Art. No.
tetrasulfonate		
21. DECYL GLUCOSIDE ⁴ <small>DO NOT PRELOAD</small>	5.0 pet	D-065

Revised January 2014

Textile Colours & Finish

TF-1000

1. Disperse Yellow 3	1.0 pet	D-036
2. DISPERSE ORANGE 3	1.0 pet	D-032
3. Disperse Red 1	1.0 pet	D-034
4. DISPERSE RED 17	1.0 pet	D-035
5. Deleted 2020		
6. DISPERSE BLUE 3	1.0 pet	D-026
7. Disperse Blue 35	1.0 pet	D-027
8. Dimethylol dihydroxy ethylene urea <small>DO NOT PRELOAD</small>	4.5 aq	D-012
9. Dimethyl dihydroxy ethylene urea <small>DO NOT PRELOAD</small>	4.5 aq	D-052
10. Dimethylol dihydroxy ethylene urea, modified <small>DO NOT PRELOAD</small>	5.0 aq	D-050
11. Disperse Blue 106	1.0 pet	D-040
12. Ethyleneurea, melamine formaldehyde mix ² <small>DO NOT PRELOAD</small>	5.0 pet	Mx-16
-Dimethylol dihydroxy ethylene urea (D-012) <small>DO NOT PRELOAD</small>	4.0	
-Melamine formaldehyde (M-001) <small>DO NOT PRELOAD</small>	1.0	
13. Urea formaldehyde resin	10.0 pet	U-001
14. Melamine formaldehyde (Kaurit M70) ³ <small>DO NOT PRELOAD</small>	7.0 pet	M-001
15. Disperse Blue 85	1.0 pet	D-028
16. Disperse Orange 1	1.0 pet	D-031
17. Acid Yellow 61	5.0 pet	A-026
18. Disperse Brown 1	1.0 pet	D-030
19. Disperse Yellow 9	1.0 pet	D-037
20. Disperse Blue 124	1.0 pet	D-041
21. Basic Red 46	1.0 pet	B-026
22. Reactive Black 5	1.0 pet	R-004B
23. Reactive Blue 21	1.0 pet	R-005B
24. Deleted 2016		
25. Reactive Orange 107	1.0 pet	R-007B
26. Reactive Red 123	1.0 pet	R-008B
27. Deleted 2018		
28. Reactive Red 228	1.0 pet	R-010B
29. Reactive Violet 5	1.0 pet	R-011B
30. Acid Red 118	5.0 pet	A-027
31. Direct Orange 34	5.0 pet	D-051

Compound	Conc. Veh. %(w/w)	Art. No.
32. Acid Red 359	5.0 pet	A-028
33. Disperse Blue mix 106/124	1.0 pet	Mx-26
-Disperse Blue 106 (D-040)	0.5	
-Disperse Blue 124 (D-041)	0.5	
34. Textile dye mix ²	6.6 pet	Mx-30
-Diperse Blue 35 (D-027)	1.0	
-Diperse Orange 1 (D-031)	1.0	
-DISPERSE ORANGE 3 (D-032)	1.0	
-Disperse Red 1 (D-034)	1.0	
-DISPERSE RED 17 (D-035)	1.0	
-Disperse Yellow 3 (D-036)	1.0	
-Disperse Blue 106 (D-040)	0.3	
-Disperse Blue 124 (D-041)	0.3	

Revised January 2020

Art. No.	Serial no.	Conc %(w/w) & Vehicle	Name
----------	------------	--------------------------	------

List of Topical Haptens

DO NOT PRELOAD Volatile hapten and not recommended to preload.

¹ Also present in European Baseline Series

² Emulsifier: SORBITAN SESQUIOLEATE 5%

³ Emulsifier: SORBITAN SESQUIOLEATE 1%

⁴ Emulsifier: SORBITAN SESQUIOLEATE 2%

⁵ Contains DECYL GLUCOSIDE

⁶ Present in national series. Visit www.chemotechnique.se for further information.

^{EC} Directive 2003/15/EC relating to cosmetic products

Art. No.	Serial no.	Conc %(w/w) & Vehicle	Name
----------	------------	--------------------------	------

A-001	O-1	10.0 pet	ABIETIC ACID
A-002	C-23, PG-19	10.0 pet	HYDROABIETYL ALCOHOL
A-003B	PL-11	0.033 pet	Alantolactone
A-004	ICB-7, C-2, O-26, LU-1, NA-7, NAE-7, NAC-7, AC-2	50.0 pet	Amerchol L-101
A-005	SH-21	0.25 pet	4-Aminoazobenzene
A-006A	<i>Deleted 2019</i>		(PABA)
A-006B	<i>Deleted 2019</i>		(PABA)
A-006C	EP-7, EPE-7, SU-2	10.0 pet	PABA
A-007	<i>Deleted 2018</i>		(N,N-DIETHYL-p-PHENYLENEDI AMINE SULFATE (TSS))
A-008	H-10	1.0 pet	m-AMINOPHENOL
A-009	H-11	1.0 pet	p-AMINOPHENOL
A-010	MET-41	0.1 aq	Ammonium hexachloroplatinate(IV) <small>DO NOT PRELOAD</small>
A-011	B-16, H-5, P-8	2.5 pet	AMMONIUM PERSULFATE
A-012	H-4	2.5 aq	AMMONIUM THIOGLYCOLATE <small>DO NOT PRELOAD</small>
A-013	MET-42	0.25 aq	Ammonium tetrachloroplatinate(II) <small>DO NOT PRELOAD</small>
A-014	F-3	2.0 pet	AMYL CINNAMAL
A-015	B-10	5.0 pet	TRANS-ANETHOLE <small>DO NOT PRELOAD</small>
A-016	PL-16	0.1 pet	Atranorin
A-017	O-19	1.0 pet	7-ETHYLBICYCLOOXAZOLIDINE <small>DO NOT PRELOAD</small>
A-018	<i>Deleted 2021</i>		(Azodiisobutyrodinitrile)
A-019	SH-4	1.0 pet	Acid Yellow 36

Art. No.	Serial no.	Conc %(w/w) & Vehicle	Name
A-020	<i>Deleted 2021</i>		(Amylocaine hydrochloride)
A-021	<i>Deleted 2017</i>		(Aluminium)
A-022	DS-24, MET-4	2.0 pet	Aluminium(III)chloride hexahydrate
A-023	CS-5	1.0 pet	Alclometasone-17,21-dipropionate
A-024	PL-3	0.5 pet	Arnica montana extract <small>DO NOT PRELOAD</small>
A-025	PL-5	1.0 pet	Achillea millefolium extract <small>DO NOT PRELOAD</small>
A-026	TF-17	5.0 pet	Acid Yellow 61
A-027	TF-30	5.0 pet	Acid Red 118
A-028	TF-32	5.0 pet	Acid Red 359
A-029	ICB-75, NAE-55, NAC-75, AC-73	0.1 aq	Amidoamine <small>DO NOT PRELOAD</small>
A-030	CAD-2	10.0 pet	Amoxicillin trihydrate
A-031	CAD-18	10.0 pet	Acetylsalicylic acid
A-032	CAD-22	10.0 pet	ACETAMINOPHEN
A-033	CAD-23	10.0 pet	Acyclovir
A-034	MET-34	0.1 aq	Ammonium hexachloroiridate(IV) <small>DO NOT PRELOAD</small>
A-035	MET-38	1.0 aq	Ammonium molybdate (VI) tetrahydrate <small>DO NOT PRELOAD</small>
A-036	F-32	5.0 pet	Amyl cinnamyl alcohol
A-037	F-33	10.0 sof	Anise alcohol
A-038	MET-48	10.0 pet	ALUMINUM HYDROXIDE
A-039	H-31	1.0 pet	4-AMINO-2-HYDROXYTOLUENE
B-001	S-15, ICB-19, H-14, IS-7, DMP-22, LA-15, NA-19, NAE-19, NAC-19, ECB-15, AC-10	25.0 pet	Peru balsam ² <small>DO NOT PRELOAD</small>
B-002	Only available as part of Mx-14		(Beech tar)
B-003B	ECB-40, O-9	0.1 pet	BENZISOTHIAZOLINONE
B-004	ICB-1, NA-1 NAE-1, NAC-1, AC-26	5.0 pet	Benzocaine
B-005	B-12, AC-77	5.0 pet	BENZOIC ACID
B-006	O-14,P-10	1.0 pet	BENZOTRIAZOLE
B-007	ICB-70, B-17, PG-7, LU-10, NAC-70	1.0 pet	Benzoylperoxide
B-008B	ICB-58, C-34, F-16, P-12, NAE-59, NAC-58, AC-80	10.0 sof	BENZYL ALCOHOL <small>DO NOT PRELOAD</small>
B-009	<i>Deleted 2015</i>		(BENZYLPARABEN)
B-010A	<i>Deleted 2011</i>		(BENZYL SALICYLATE)
B-010B	ICB-52, C-30 NAC-52, F-15, AC-83	10.0 pet	BENZYL SALICYLATE

Art. No.	Serial no.	Conc %(w/w) & Vehicle	Name
B-011	Only available as part of Mx-14 (Birch tar)		
B-013	PG-10	1.0 pet	Bisphenol A
B-014	⁶	1.0 pet	Bithionol
B-015A	C-31, H-19, O-29	0.25 pet	2-BROMO-2-NITROPROPANE-1,3-DIOL
B-015B	ICB-30, NA-30 NAE-30, NAC-30, ECB-32, AC-23	0.5 pet	2-BROMO-2-NITROPROPANE-1,3-DIOL
B-016	MP-13	0.1 pet	1,4-Butanediol diacrylate
B-017	DS-8, MA-7, DMP-9, DMS-7	2.0 pet	1,4-Butanediol dimethacrylate <small>DO NOT PRELOAD</small>
B-018	MN-1	0.1 pet	Butyl acrylate <small>DO NOT PRELOAD</small>
B-019	O-8	1.0 pet	4-tert-Butylbenzoic acid (BUTYLPARABEN)
B-020	<i>Deleted 2021</i>		
B-021	MA-2, MN-3, MP-7	2.0 pet	BUTYL METHACRYLATE <small>DO NOT PRELOAD</small>
B-022	ICB-37, B-9, C-6, PG-18, NAC-37	2.0 pet	2-tert-Butyl-4-methoxyphenol (BHA)
B-023	PG-20	1.0 pet	4-tert-Butylphenol
B-024	S-16, ICB-15, PG-13, SH-8, NAE-15, IS-11, LA-16, NA-15, NAC-15, ECB-16, AC-13	1.0 pet	4-tert-Butylphenolformaldehyde resin (PTBP)
B-025	<i>Deleted 2018</i>		(Tolu balsam absolute <small>DO NOT PRELOAD</small>)
B-026	TF-21	1.0 pet	Basic Red 46
B-027	LU-4, AC-60	0.1 aq	BENZALKONIUM CHLORIDE <small>DO NOT PRELOAD</small>
B-027B	<i>Deleted 2020</i>		(BENZALKONIUM CHLORIDE)
B-028	C-36	1.0 pet	t-BUTYL HYDROQUINONE
B-029B	<i>Deleted 2019</i>		(BUTYL METHOXYDIBENZOYLMETHANE)
B-029C	SU-1, EP-8, EPE-8	10.0 pet	BUTYL METHOXYDIBENZOYLMETHANE
B-030B	PG-8	0.25 pet	4-tert-Butylcatechol
B-031	CS-2	1.0 pet	Betamethasone-17-valerate
B-032A	ME-7, LU-6	5.0 pet	Bacitracin
B-032B	ICB-23, NA-23 NAE-23, NAC-23, AC-33	20.0 pet	Bacitracin
B-033A	ICB-45, NA-45, NAE-45, NAC-45, AC-30	0.1 pet	Budesonide
B-033B	S-24, CS-1, LU-17, IS-15, LA-24, ECB-24	0.01 pet	Budesonide
B-035	E-10	0.25 pet	Epoxy resin, Bisphenol F
B-036	<i>Deleted 2021</i>		(1,4-Butanediol diglycidyl ether)
B-037	SU-16, EP-9,	10.0 pet	BIS-ETHYLHEXYLOXYPHENOL

Art. No.	Serial no.	Conc % (w/w) & Vehicle	Name
B-038	EPE-9		METHOXYPHENOL TRIAZINE
B-039	F-34	10.0 pet	BENZYL BENZOATE
B-040	F-35	10.0 pet	BENZYL CINNAMATE
B-041	F-36	10.0 pet	BUTYLPHENYL METHYLPROPIONAL
B-042	EP-18, EPE-18	2.0 pet	Benzylamine hydrochloride
B-043	CS-10	1.0 pet	Betamethasone 17,21-dipropionate
B-044	ME-17	5.0 pet	Bufexamac
C-001	MET-54	1.0 pet	Beryllium(II)sulfate tetrahydrate
C-002	MET-33	1.0 aq	Cadmium chloride <small>DO NOT PRELOAD</small>
C-003	F-19	2.0 pet	Cananga oil <small>DO NOT PRELOAD</small>
C-004	C-29	5.0 pet	CETYL ALCOHOL
C-005	V-3	0.5 aq	CHLORHEXIDINE DIACETATE <small>DO NOT PRELOAD</small>
C-006	C-16, LU-3, AC-52	0.5 aq	CHLORHEXIDINE DIGLUCONATE <small>DO NOT PRELOAD</small>
C-007A	H-15, C-19, O-12, LU-24	0.2 pet	CHLOROACETAMIDE
C-007B	S-21, H-24, C-40	1.0 pet	QUATERNIUM-15
C-008	LA-21, ECB-21		
C-009A	ICB-14, IS-16	2.0 pet	QUATERNIUM-15
C-009B	NA-14, NAE-14, NAC-14, AC-18		
C-009C	C-11, H-21, O-2, LU-16, AC-90	1.0 pet	p-CHLORO-m-CRESOL
C-009D	LA-23 ⁶ , AC-17	0.01 aq	METHYLISOTHIAZOLINONE + METHYLCHLOROISOTHIAZOLINONE <small>DO NOT PRELOAD</small>
C-009E	S-23, ICB-78, C-35, O-31, SH-20, H-18, NA-25, NAE-25, NAC-78, ECB-23	0.02 aq	METHYLISOTHIAZOLINONE + METHYLCHLOROISOTHIAZOLINONE <small>DO NOT PRELOAD</small>
C-010A	⁶	0.01 pet	METHYLISOTHIAZOLINONE + METHYLCHLOROISOTHIAZOLINONE <small>DO NOT PRELOAD</small>
C-010B	<i>Deleted 2021</i>		
C-011	IS-17	0.215 aq	METHYLISOTHIAZOLINONE + METHYLCHLOROISOTHIAZOLINONE <small>DO NOT PRELOAD</small>
C-012	C-12, H-22, O-3	0.5 pet	CHLOROXYLENOL (PCMX)
C-013	ICB-35, NAE-35, NAC-35, AC-54	1.0 pet	CHLOROXYLENOL (PCMX)
C-014	<i>Deleted 2021</i>		(Chlorpromazine hydrochloride)
C-015	<i>Deleted 2021</i>	t	(Chlorquinaldol)
C-016	B-7, F-2	2.0 pet	CINNAMYL ALCOHOL <small>DO NOT PRELOAD</small>
C-017A	ICB-6, B-8, F-1	1.0 pet	CINNAMAL <small>DO NOT PRELOAD</small>
C-018	NA-6, NAE-6, NAC-6, AC-46		
C-019	C-21, LA-8	5.0 pet	Clioquinol
C-020	V-4	5.0 pet	Coal tar <small>DO NOT PRELOAD</small>

Art. No.	Serial no.	Conc % (w/w) & Vehicle	Name
C-017A	S-5, ICB-43, DS-12, H-8, IS-22, DMP-13, LA-5, NA-43, NAE-43, NAC-43, ECB-5, AC-12, MET-6	1.0 pet	Cobalt(II)chloride hexahydrate
C-017B	<i>Deleted 2020</i>		(Cobalt(II)chloride hexahydrate)
C-018	ICB-76, C-33, H-17	1.0 aq	COCAMIDOPROPYL BETAINE <small>DO NOT PRELOAD</small>
C-019	LA-30, NA-49, NAE-49, NAC-76, AC-40		
C-020	ICB-46, O-30	0.5 pet	COCAMIDE DEA
C-021	NAE-63, NAC-46, AC-58		
C-022	S-9, ICB-3, DS-17, SH-11, IS-6, DMP-17, NA-3, NAE-3, LA-9, NAC-3, ECB-9, AC-7	20.0 pet	COLOPHONIUM
C-023	MET-11	5.0 pet	Copper(I)oxide
C-024	DS-21, MET-9	2.0 pet	Copper(II)sulfate pentahydrate
C-025	R-9	1.0 pet	N-Cyclohexyl-2-benzothiazolylsulfenamide
C-026	R-5	1.0 pet	N-Cyclohexyl-N-phenyl-4-phenylenediamine
C-027	H-20	0.5 pet	Captan
C-028	DS-25	1.0 pet	BORNANEDIONE
C-029	<i>Deleted 2019</i>		(Cyclohexanone resin)
C-030	ICB-11, CS-6	1.0 pet	Clobetasol-17-propionate
C-031	NAE-54, NAC-11, AC-72		
C-032	PL-1	1.0 pet	Anthemis nobilis extract <small>DO NOT PRELOAD</small>
C-033	PL-7	1.0 pet	Chrysanthemum Cinerariaefolium extract <small>DO NOT PRELOAD</small>
C-034	ME-1, LU-9	5.0 pet	Chloramphenicol
C-035	LU-7, AC-81	20.0 pet	CETEARYL ALCOHOL
C-036	R-25	1.0 pet	N-(Cyclohexylthio) phthalimide
C-037	DS-32, DMP-20	5.0 pet	CARVONE <small>DO NOT PRELOAD</small>
C-038	F-26	2.0 pet	CITRAL
C-039	F-28	1.0 pet	CITRONELLOL <small>DO NOT PRELOAD</small>
C-040	F-30	5.0 pet	COUMARIN
C-041	Only available as a part of Mx-18		
C-042	CAD-4	10.0 pet	Cefotaxim sodium salt
C-043	CAD-9	10.0 pet	Clarithromycin
C-044	CAD-11	10.0 pet	Cotrimoxazole
C-045	CAD-13	10.0 pet	Ciprofloxacin hydrochloride
C-046	CAD-14	1.0 pet	Carbamazepine
	CAD-17	5.0 pet	Captopril
	CAD-26	10.0 pet	Clindamycin phosphate

Art. No.	Serial no.	Conc %(w/w) & Vehicle	Name
C-047	CAD-27	10.0 pet	Cefradine
C-048	CAD-28	10.0 pet	Cefalexin
C-049	MET-20	10.0 pet	CALCIUM TITANATE
C-050	H-36	0.5 pet	CETRIMONIUM BROMIDE
C-051	PL-14	1.0 pet	Chamomilla recutita extract <small>[DO NOT PRELOAD]</small>
C-052	H-32	0.5 pet	CYSTEAMINE HCL
C-053	CAD-31	10.0 pet	Cefuroxime sodium
C-054	CAD-32	10.0 pet	Cefixime trihydrate
C-055	CAD-34	10.0 pet	Cefpodoxime proxetil
C-056	C-61	5.0 pet	CETEARYL GLUCOSIDE
D-001	E-2,I-3,R-18	0.5 pet	4,4'-Diaminodiphenylmethane (MDA)
D-002	H-2	1.0 pet	TOLUENE-2,5-DIAMINE SULFATE
D-003	R-10	1.0 pet	Dibenzothiazyl disulfide (MBTS)
D-005A	V-16	5.0 pet	Dibucaine hydrochloride
D-005B	ICB-69, NAE-52, NAC-69	2.5 pet	Dibucaine hydrochloride
D-006	B-5, C-7, PG-5 LU-8, AC-78	2.0 pet	BHT
D-007	PG-2	5.0 pet	Dibutyl phthalate
D-008	O-4	1.0 pet	DICHLOROPHENE
D-009	MP-15	0.1 pet	Di(ethylene glycol) diacrylate
D-010	E-5	1.0 pet	Diethylenetriamine, (DETA) <small>[DO NOT PRELOAD]</small>
D-011	<i>Deleted 2018</i>		(N,N-DIETHYLTOLUENE-2,5-DIAMINE HCL)
D-012	TF-8	4.5 aq	Dimethylol dihydroxy ethylene urea <small>[DO NOT PRELOAD]</small>
D-014	<i>Deleted 1999</i>		(Dimethylol propyleneurea)
D-015	O-20	1.0 pet	Bioban CS 1135 <small>[DO NOT PRELOAD]</small>
D-016	DS-6	5.0 pet	N,N-Dimethyl-4-toluidine <small>[DO NOT PRELOAD]</small>
D-017	R-15	1.0 pet	N,N-Di-2-naphthyl-4-phenylenediamine (DBNPD)
D-018	PG-4	2.0 pet	Diocetyl phthalate (DEHP, DOP)
D-019	R-4	1.0 pet	Dipentamethylenethiuram disulfide
D-020	<i>Deleted 2014</i>		(DIPENTENE (oxidized))
D-021	ME-20	1.0 pet	Diphenhydramine hydrochloride
D-022	ICB-17, R-12, SH-16, NA-17, NAE-17, NAC-17, AC-68	1.0 pet	1,3-Diphenylguanidine
D-023	<i>Deleted 2012</i>		(Diphenylmethane-4,4'-diisocyanate (MDI))
D-023B	I-2	0.5 pet	Diphenylmethane-4,4'-diisocyanate (MDI) <small>[DO NOT PRELOAD]</small>
D-024	R-6	1.0 pet	N,N'-Diphenyl-p-phenylenediamine (DPPD)

Art. No.	Serial no.	Conc %(w/w) & Vehicle	Name
D-025	PG-22, R-19, SH-13	1.0 pet	N,N'-Diphenylthiourea (DPTU)
D-026	TF-6	1.0 pet	DISPERSE BLUE 3
D-027	TF-7	1.0 pet	Disperse Blue 35
D-028	TF-15	1.0 pet	Disperse Blue 85
D-029	<i>Deleted 2019</i>		(Disperse Blue 153)
D-030	TF-18	1.0 pet	Disperse Brown 1
D-031	TF-16	1.0 pet	Disperse Orange 1
D-032	ICB-25, TF-2, SH-3, NAC-25, AC-76	1.0 pet	DISPERSE ORANGE 3
D-033	<i>Deleted 1999</i>		(Disperse Orange 13)
D-034	TF-3	1.0 pet	Disperse Red 1
D-035	TF-4	1.0 pet	DISPERSE RED 17
D-036	ICB-51, TF-1, NAC-51, AC-84	1.0 pet	Disperse Yellow 3
D-037	TF-19	1.0 pet	Disperse Yellow 9
D-038	SH-17, R-23	1.0 pet	N,N'-Dibutylthiourea
D-039	SH-15, R-22	1.0 pet	N,N'-Diethylthiourea
D-040	TF-11	1.0 pet	Disperse Blue 106
D-041	TF-20	1.0 pet	Disperse Blue 124
D-042	B-19, C-39	0.25 pet	DODECYL GALLATE
D-043	R-24, SH-19	0.1 pet	Dodecyl mercaptan <small>[DO NOT PRELOAD]</small>
D-044A	C-42, H-26, IS-24, LU-25, LA-31, ECB-33	2.0 pet	DIAZOLIDINYL UREA
D-044B	<i>Deleted 2021</i>		(DIAZOLIDINYL UREA <small>[DO NOT PRELOAD]</small>)
D-044C	ICB-21, NA-21, NAE-21, NAC-21, AC-25	1.0 pet	DIAZOLIDINYL UREA
D-045	DS-26, MA-14, DMP-7	0.2 pet	DIMETHYLAMINOETHYL METHACRYLATE <small>[DO NOT PRELOAD]</small>
D-046	CS-7	1.0 pet	Dexamethasone-21-phosphate disodium salt
D-047A	C-44	2.0 aq	DMDM HYDANTOIN <small>[DO NOT PRELOAD]</small>
D-047B	ICB-56, NA-22, NAE-22, NAC-56, AC-5	1.0 pet	DMDM HYDANTOIN ³ <small>[DO NOT PRELOAD]</small>
D-048	PL-2	1.0 pet	Diallyl disulfide <small>[DO NOT PRELOAD]</small>
D-049A	IS-20	0.3 pet	METHYLDIBROMO GLUTARONITRILE
D-049C	<i>Deleted 2014</i>	0.1 pet	(METHYLDIBROMO GLUTARONITRILE)
D-049E	S-26, ICB-27, O-34, C-45, LA-26, NA-27, NAE-27, NAC-27, ECB-26	0.5 pet	METHYLDIBROMO GLUTARONITRILE
D-050	TF-10	5.0 aq	Dimethylol dihydroxy ethylene urea, modified <small>[DO NOT PRELOAD]</small>

Art. No.	Serial no.	Conc %(w/w) & Vehicle	Name
D-051	TF-31	5.0 pet	Direct Orange 34
D-052	TF-9	4.5 aq	Dimethyl dihydroxy ethylene urea <small>DO NOT PRELOAD</small>
D-053	C-48, E-9, AC-42	1.0 aq	3-(Dimethylamino)-1-propylamine <small>DO NOT PRELOAD</small>
D-054	SH-23, R-27	1.0 pet	4,4'-Dithiodimorpholine
D-055	SU-11, EP-10, EPE-10	10.0 pet	DROMETRIZOLE TRISILOXANE
D-056	Only available as a part of Mx-18		
D-057	ICB-61, CS-9 NAE-57, NAC-61	1.0 pet	Desoximetasone
D-058	CAD-3	10.0 pet	Dicloxacillin sodium salt hydrate
D-059	CAD-5	10.0 pet	Doxycycline monohydrate
D-060	CAD-16	10.0 pet	Diltiazem hydrochloride
D-061A	<i>Deleted 2021</i> (Diclofenac sodium salt)		
D-061B	EPE-30	5.0 pet	Diclofenac sodium salt
D-062	SU-18, EP-12, EPE-12	10.0 pet	2-(4-Diethylamino-2-hydroxybenzoyl) benzoic acid hexylester
D-063	SU-19, EP-16, EPE-16	10.0 pet	DIETHYLHEXYL BUTAMIDO TRIAZONE
D-064	SU-20, EPE-26	10.0 pet	Disodium phenyl dibenzimidazole tetrasulfonate
D-065	ICB-53, C-57, H-29, EP-20, SU-21, EPE-34, NA-47, NAE-53, NAC-53, ECB-42, AC-45	5.0 pet	DECYL GLUCOSIDE ⁴ <small>DO NOT PRELOAD</small>
D-066A	<i>Deleted 2018</i> (Dimethyl fumarate <small>DO NOT PRELOAD</small>)		
D-066B	SH-24	0.01 pet	Dimethyl fumarate <small>DO NOT PRELOAD</small>
D-067	<i>Deleted 2021</i> (Dexketoprofen)		
E-001	<i>Deleted 2019</i> (Epoxy acrylate)		
E-002	S-14, ICB-13, IS-10, SH-18, DMP-23, LA-14, NA-13, NAE-13, NAC-13, ECB-14, AC-14	1.0 pet	Epoxy resin, Bisphenol A
E-003	<i>Deleted 2011</i> (Ethoxyquin)		
E-004	ICB-39, MN-11, MP-1, NA-39, NAE-39, NAC-39, AC-50	0.1 pet	Ethyl acrylate <small>DO NOT PRELOAD</small>
E-005	ICB-12, C-22, O-15, E-8, P-9, NA-12, NAE-12, NAC-12, AC-11	1.0 pet	Ethylenediamine dihydrochloride
E-006	V-2	1.0 pet	Ethylenediaminetetraacetic acid disodium salt dihydrate
E-007	DS-4, MA-5, MN-6, MP-10, DMP-3, DMS-3	2.0 pet	Ethylene glycol dimethacrylate <small>DO NOT PRELOAD</small>

Art. No.	Serial no.	Conc %(w/w) & Vehicle	Name
E-008	<i>Deleted 2018</i>		(Ethylene urea)
E-009	<i>Deleted 2021</i>		(2-Ethylhexyl acrylate)
E-010	V-8	3.0 pet	ETHYLPARABEN
E-011	<i>Deleted 2018</i>		(N-Ethyl-N-(2-hydroxyethyl)-2-methyl- 1,4-phenylenediamine sulfate salt)
E-012	MN-2, MP-6	2.0 pet	ETHYL METHACRYLATE <small>DO NOT PRELOAD</small>
E-013	<i>Deleted 2018</i>		(N-Ethyl-N-(2-methane- sulfonamidoethyl)-2-methyl-1,4- PPD-sesquisulfate, hydrate (CD-3))
E-014	O-11	0.5 pet	Bioban P 1487 <small>DO NOT PRELOAD</small>
E-015	DS-18, DMP-18	0.1 pet	N-Ethyl-p-toluenesulfonamide
E-016	B-2, DS-16, F-4, DMP-16, DMS-9	2.0 pet	EUGENOL <small>DO NOT PRELOAD</small>
E-017	PL-17	0.1 pet	Evermic acid
E-018B	<i>Deleted 2019</i>		(ETHYLHEXYL DIMETHYL PABA)
E-018C	<i>Deleted 2019</i>		(ETHYLHEXYL DIMETHYL PABA)
E-018D	SU-5	10.0 pet	ETHYLHEXYL DIMETHYL PABA
E-019B	<i>Deleted 2019</i>		(ETHYLHEXYL METHOXYCINNAMATE)
E-019C	SU-7, EP-4, EPE-4	10.0 pet	ETHYLHEXYL METHOXYCINNAMATE AC-79
E-020	<i>Deleted 2019</i>		(Epoxy resin, cycloaliphatic)
E-021	ME-11	1.0 alc	Econazole nitrate <small>DO NOT PRELOAD</small>
E-022	LU-15	5.0 pet	Eosin
E-023	MA-15, AC-74	10.0 pet	ETHYL CYANOACRYLATE <small>DO NOT PRELOAD</small>
E-024	CAD-7	10.0 pet	Erythromycin base
E-025	EP-15, EPE-15	2.0 pet	Etofenamate
E-026	F-37	1.0 pet	Treemoss absolute <small>DO NOT PRELOAD</small>
E-027	C-58, AC-70	5.0 pet	ETHYLHEXYLGLYCERIN
F-001	6	1.0 pet	2,2'-THIOBIS(4-CHLOROPHENOL)
F-002A	6	1.0 aq	FORMALDEHYDE <small>DO NOT PRELOAD</small>
F-002B	S-18, ICB-77, DS-19, H-6, IS-5, O-25, AC-21 SH-12, NA-11, NAE-11, NAC-77, ECB-18	2.0 aq	FORMALDEHYDE <small>DO NOT PRELOAD</small>
F-002C	LA-18 ⁶	1.0 pet	FORMALDEHYDE ³ <small>DO NOT PRELOAD</small>
F-003	ICB-68, LU-2, ME-13, NAE-62 NAC-68	2.0 pet	Fusidic acid sodium salt
F-004	F-27	5.0 pet	FARNESOL
F-005	LU-19, ME-8	20.0 pet	Framycetin sulphate
F-006	EPE-31	10.0 pet	Fenofibrate

Art. No.	Serial no.	Conc % (w/w) & Vehicle	Name
G-001	F-6	2.0 pet	GERANIOL <small>DO NOT PRELOAD</small>
G-002	F-22	2.0 pet	Geranium oil <small>DO NOT PRELOAD</small>
G-003A	DS-34, SH-2, P-11, DMS-10	0.2 pet	GLUTARAL ² <small>DO NOT PRELOAD</small>
G-003B	ICB-29, NA-29, NAE-29, NAC-29	0.5 pet	GLUTARAL ² <small>DO NOT PRELOAD</small>
G-004	ICB-40, H-16, NAC-40	1.0 pet	GLYCERYL THIOGLYCOLATE <small>DO NOT PRELOAD</small>
G-005A	ICB-38, MET-10, NAC-38	0.5 pet	Gold(I)sodium thiosulfate dihydrate
G-005B	DS-14, DMP-14, MET-8, AC-28	2.0 pet	Gold(I)sodium thiosulfate dihydrate
G-006	ME-5	20.0 pet	Gentamicin sulfate
G-007	MET-44	1.0 pet	Gallium(III)oxide
H-001	⁶	1.0 pet	Hexachlorophene
H-002	C-20, O-10	1.0 aq	Hexahydro-1,3,5-tris-(2-hydroxyethyl) triazine <small>DO NOT PRELOAD</small>
H-003	C-15, E-1, R-17	2.0 pet	METHENAMINE
H-004	DS-27, MA-11, MN-8, MP-14, DMP-10	0.1 pet	1,6-Hexanediol diacrylate
H-005	O-23	1.0 pet	Hydrazine sulfate
H-006	<i>Deleted 2019</i>		(HYDROGEN PEROXIDE)
H-007	H-13, PG-1, P-5	1.0 pet	HYDROQUINONE
H-008	F-8	2.0 pet	HYDROXYCITRONELLAL
H-009	MN-12, MP-3	0.1 pet	2-Hydroxyethyl acrylate <small>DO NOT PRELOAD</small>
H-010	DMS-5, DMP-6, DS-13, ECB-8, ICB-55, MA-3, MN-4, MP-8, AC-43, NA-34, NAE-56, NAC-55, S-8	2.0 pet	2-Hydroxyethyl methacrylate <small>DO NOT PRELOAD</small>
H-011	<i>Deleted 2018</i>		(HYDROXYLAMINE HCL <small>DO NOT PRELOAD</small>)
H-012	<i>Deleted 2018</i>		(HYDROXYLAMINE SULFATE <small>DO NOT PRELOAD</small>)
H-013	DS-5, MA-10, DMP-4, DMS-4	2.0 pet	Bisphenol A glycerolate dimethacrylate (BIS-GMA)
H-014C	ICB-34, C-25, DS-7, SU-6, AC-55, EP-1, EPE-1, NAE-34, NAC-34	10.0 pet	BENZOPHENONE-3
H-015	O-21	1.0 pet	TRIS(HYDROXYMETHYL)NITRO-METHANE
H-016	C-37, DS-28, PG-6, DMP-21	1.0 pet	DROMETRIZOLE

Art. No.	Serial no.	Conc % (w/w) & Vehicle	Name
H-017	<i>Deleted 2021</i>		(Hydroxypropyl acrylate)
H-018	MA-4, MN-5, MP-9	2.0 pet	Hydroxypropyl methacrylate <small>DO NOT PRELOAD</small>
H-019	SH-5	1.0 pet	Hydroquinone monobenzylether
H-020B	EPE-21, SU-8	10.0 pet	BENZOPHENONE-10
H-021A	CS-8	1.0 alc	Hydrocortisone-17-butyrate <small>DO NOT PRELOAD</small>
H-021B	LA-39, AC-31	1.0 pet	Hydrocortisone-17-butyrate
H-022	I-6	0.1 pet	Hexamethylene diisocyanate (HDI) <small>DO NOT PRELOAD</small>
H-023B	<i>Deleted 2019</i>		(BENZOPHENONE-4)
H-023C	EP-2, EPE-2, SU-10, AC-61	2.0 pet	BENZOPHENONE-4
H-024A	SU-3	5.0 pet	HOMOSALATE
H-024B	EPE-23	10.0 pet	HOMOSALATE
H-025	F-29	10.0 pet	Hexyl cinnamic aldehyde
H-026	<i>Deleted 2021</i>		(1,6-Hexanediol diglycidylether)
H-027	CAD-15	10.0 pet	Hydantoin
H-028	CAD-24	1.0 pet	Hydroxyzine hydrochloride
H-029	CAD-25	10.0 pet	Hydrochlorotiazide
H-031A	ICB-74, F-43, NA-40, NAE-40, NAC-74, ECB-36	1.0 pet	Hydroperoxides of Linalool <small>DO NOT PRELOAD</small>
H-031B	F-46, ECB-37, AC-190.5	0.5 pet	Hydroperoxides of Linalool <small>DO NOT PRELOAD</small>
H-032A	ICB-60, B-15, F-44, O-27, NA-36, NAE-36, NAC-60, ECB-38	0.3 pet	Hydroperoxides of Limonene <small>DO NOT PRELOAD</small>
H-032B	F-47, ECB-39, AC-59	0.2 pet	Hydroperoxides of Limonene <small>DO NOT PRELOAD</small>
H-033	H-34	2.0 pet	HYDROXYETHYL-p-PHENYLENE-DIAMINE SULFATE
H-034	CS-13	1.0 pet	Hydrocortisone-21-acetate
I-001A	ICB-5, C-14, H-23, LU-26, LA-40, NA-5, NAE-5, NAC-5, ECB-34, AC-29	2.0 pet	IMIDAZOLIDINYL UREA
I-001B	<i>Deleted 2019</i>		(IMIDAZOLIDINYL UREA)
I-002	B-3, F-5	2.0 pet	ISOEUGENOL <small>DO NOT PRELOAD</small>
I-003	ICB-59, C-1, NAC-59	20.0 pet	ISOPROPYL MYRISTATE
I-004	S-11, IS-28, SH-1, R-7, LA-11, ECB-11	0.1 pet	N-Isopropyl-N-phenyl-4-phenylenediamine (IPPD)

Art. No.	Serial no.	Conc %(w/w)	Name & Vehicle
I-005	Deleted 1999		(4-Isopropyl-dibenzoylmethane)
I-006	E-6, I-5	0.1 pet	Isophorone diamine (IPD) <small>DO NOT PRELOAD</small>
I-007	I-4	1.0 pet	ISOPHORONE DIISOCYANATE (IPDI) <small>DO NOT PRELOAD</small>
I-008C	ICB-63, C-47, O-35, NA-37, NAE-37, NAC-63, AC-38	0.2 pet	IODOPROPYNYL BUTYL CARBAMATE
I-009	ICB-71, SU-15, EP-6, EPE-6, NAC-71	10.0 pet	ISOAMYL p-METHOXYCINNAMATE
I-010A	CAD-29	10.0 pet	Ibuprofen
I-010B	EPE-29	5.0 pet	Ibuprofen
I-011	MET-35	10.0 aq	Indium(III)chloride <small>DO NOT PRELOAD</small>
I-012	MET-13	1.0 pet	Iridium(III)chloride trihydrate
I-013	MET-37	10.0 aq	Indium(III)sulfate <small>DO NOT PRELOAD</small>
I-014	MET-14	1.0 pet	Iridium
I-015	MET-15	1.0 pet	Indium
I-016	MET-29	2.0 pet	FERRIC CHLORIDE
I-017	F-38	10.0 pet	α -Isomethyl ionone <small>DO NOT PRELOAD</small>
I-018	Deleted 2018		(Imipenem monohydrate)
I-019	MA-16, MP-20	0.1 pet	ISOBORNYL ACRYLATE
J-001	F-14	2.0 pet	Jasmine synthetic <small>DO NOT PRELOAD</small>
J-002	F-23, AC-85	2.0 pet	Jasmine absolute <small>DO NOT PRELOAD</small>
J-003	Only available as a part of Mx-14 (Juniperus oxycedrus extract <small>DO NOT PRELOAD</small>)		
K-001	ME-2	10.0 pet	Kanamycin sulfate
K-002B	CAD-20, EP-11, EPE-11	1.0 pet	Ketoprofen
L-001	F-18, AC-47	2.0 pet	Lavender absolute <small>DO NOT PRELOAD</small>
L-002A	V-25	5.0 pet	Lidocaine
L-002B	ICB-67, NAE-51, NAC-67, AC-36	15.0 pet	Lidocaine
L-003	S-28, ICB-72, F-25, IS-27, LA-28, ECB-28, NAE-58, NAC-72, AC-69	5.0 pet	HYDROXYISOHEXYL 3-CYCLOHEX-ENE CARBOXALDEHYDE
L-004	C-49, H-27, ECB-43, AC-89	3.0 pet	LAURYL POLYGLUCOSE <small>DO NOT PRELOAD</small>
L-005B	F-40	10.0 pet	LINALOOL <small>DO NOT PRELOAD</small>
L-006C	F-39	10.0 pet	d-Limonene <small>DO NOT PRELOAD</small>
L-007	Deleted 2019		(Lead(II)acetate trihydrate)

Art. No.	Serial no.	Conc %(w/w)	Name & Vehicle
L-008	MET-40	0.2 aq	Lead(II)chloride <small>DO NOT PRELOAD</small>
L-009	CAD-30	10.0 pet	Lamotrigine
M-001	TF-14	7.0 pet	Melamine formaldehyde ³ <small>DO NOT PRELOAD</small>
M-002	B-6	2.0 pet	MENTHOL <small>DO NOT PRELOAD</small>
M-003A	S-17, O-16, R-8, SH-14, LA-17, ECB-17	2.0 pet	2-Mercaptobenzothiazole (MBT)
M-003B	ICB-2, NAE-2, NAC-2, AC-32	1.0 pet	2-Mercaptobenzothiazole (MBT)
M-004	MET-3	0.1 pet	Mercury(II)chloride
M-005	DS-11, DMP-12, DMS-8, MET-2	0.5 pet	Mercury <small>DO NOT PRELOAD</small>
M-006B	DS-33, DMP-5, MP-12	2.0 pet	2,2-bis(4-(2-Methacryl-oxoethoxy)phenyl)-propane (BIS-EMA)
M-007	DS-9, MA-9	2.0 pet	Bisphenol A dimethacrylate (BIS-MA) <small>DO NOT PRELOAD</small>
M-008	LA-22, PL-18	0.01 pet	2-Methoxy-6-n-pentyl-4-benzoquinone
M-009	Deleted 2018		(p-METHYLAMINOPHENOL SULFATE)
M-010A	Deleted 2018		(6-METHYL COUMARIN)
M-010B	⁶	1.0 alc	6-METHYL COUMARIN <small>DO NOT PRELOAD</small>
M-012	Deleted 2021		(METHYL PARABEN)
M-013	ICB-42, DS-1, MA-1, MP-5, DMP-1, DMS-1, NA-42, NAE-42, NAC-42, AC-46	2.0 pet	Methyl methacrylate <small>DO NOT PRELOAD</small>
M-014	O-13	0.1 pet	N-Methylolchloroacetamide
M-015	PG-21	1.0 pet	2-Monomethylol phenol
M-016	R-11	1.0 pet	2-(4-Morpholinylmercapto)benzothiazol (MOR)
M-018	Deleted 2021		(MUSK KETONE)
M-019	F-12	1.0 pet	Musk moskene
M-020	Deleted 1999		(Musk tibetine)
M-021	F-10	1.0 pet	Musk xylene
M-022	MET-5	1.0 pet	Mercury(II)amidochloride
M-023	MP-24	1.0 pet	N,N-Methylene-bisacrylamide
M-024B	SU-4, EP-3, EPE-3	10.0 pet	4-METHYLBENZYLIDENE CAMPHOR
M-025	DS-22	1.0 pet	Methylhydroquinone
M-026	PL-9	0.01 pet	α -Methylene- γ -butyrolactone <small>DO NOT PRELOAD</small>
M-027	ME-10	1.0 alc	Miconazole <small>DO NOT PRELOAD</small>
M-028	F-11	5.0 pet	METHYL ANTHRANILATE
M-029	Deleted 2019		(Minocycline hydrochloride)

Art. No.	Serial no.	Conc %(w/w) & Vehicle	Name
M-030	MET-23	5.0 pet	Molybdenum
M-031	MET-25	2.0 pet	MANGANESE CHLORIDE
M-032	<i>Deleted 2018</i>		(Methylene bis-benzotriazolyl tetramethylbutylphenol <small>DO NOT PRELOAD</small>)
M-033	F-42	5.0 pet	Majanthole
M-034	F-41	0.2 pet	Methyl-2-octynoate <small>DO NOT PRELOAD</small>
M-035A	<i>Deleted 2021</i>		(METHYLISOTHIAZOLINONE)
M-035B	S-29, ICB-54, C-54, LA-37, NA-50, NAE-50, NAC-54, ECB-29, AC-9	0.2 aq	METHYLISOTHIAZOLINONE <small>DO NOT PRELOAD</small>
M-035C	<i>Deleted 2021</i>		(METHYLISOTHIAZOLINONE)
M-035D	V-39	0.2 pet	METHYLISOTHIAZOLINONE ³ <small>DO NOT PRELOAD</small>
M-036	CS-11	1.0 pet	Methylprednisolone aceponate
M-037	EP-14, EPE-14 SU-17	10.0 pet	Methylene bis-benzotriazolyl tetramethyl-butylphenol
M-038	MET-49	0.5 pet	Molybdenum(V)chloride
M-039	H-33	1.0 pet	2-METHYLRESORCINOL
M-040	H-35	1.0 pet	p-METHYLAMINOPHENOL
Mx-01	S-3, ICB-10, IS-3, SH-6, LA-3, NA-10, NAE-10, NAC-10 ECB-3, AC-24	1.0 pet 0.25 0.25 0.25 0.25	Thiuram mix -Dipentamethylenethiuram disulfide (D-019) -Tetraethylthiuram disulfide (TETD) (T-002) -Tetramethylthiuram disulfide (TMTD) (T-005) -Tetramethylthiuram monosulfide (TMTM) (T-006)
Mx-02	V-27	6.0 pet 3.0 3.0	Quinoline mix -Chlorquinaldol (C-012) -Clioquinol (C-015)
Mx-03A	ICB-26, NA-26 NAE-26, NAC-26 AC-8	12.0 pet 3.0 3.0 3.0 3.0	Paraben mix -BUTYLPARABEN (B-020) -ETHYLPARABEN (E-010) -METHYLPARABEN (M-012) -PROPYLPARABEN (P-020)
Mx-03C	S-10, C-17, IS-29, LA-10 ECB-10	16.0 pet 4.0 4.0 4.0 4.0	Paraben mix -BUTYLPARABEN (B-020) -ETHYLPARABEN (E-010) -METHYLPARABEN (M-012) -PROPYLPARABEN (P-020)
Mx-04	V-26, AC-16	0.6 pet 0.25	Black rubber mix -N-Cyclohexyl-N-phenyl-4-phenylene-diamine (C-024)

Art. No.	Serial no.	Conc %(w/w) & Vehicle	Name
		0.25	-N,N'-Diphenyl-p-phenylenediamine (D-024)
		0.1	-N-Isopropyl-N-phenyl-4-phenylene-diamine (IPPD) (I-004)
Mx-05A	S-13, LA-13, ECB-13	2.0 pet 0.5	Mercapto mix -N-Cyclohexyl-2-benzothiazyl-sulfenamide (C-023)
		0.5	-Dibenzothiazyl disulfide (MBTS) (D-003)
		0.5	- 2-Mercaptobenzothiazole (MBT) (M-003)
		0.5	-2-(4-Morpholinylmercapto)benzothiazol (MOR) (M-016)
Mx-05B	ICB-16, NAE-16 NAC-16, AC-22	1.0 pet 0.25	Mercapto mix -N-Cyclohexyl-2-benzothiazyl-sulfenamide (C-023)
		0.25	-Dibenzothiazyl disulfide (MBTS) (D-003)
		0.25	- 2-Mercaptobenzothiazole (MBT) (M-003)
		0.25	-2-(4-Morpholinylmercapto)benzothiazol (MOR) (M-016)
Mx-05C	IS-9	3.5 pet 0.5	Mercapto mix -N-Cyclohexyl-2-benzothiazyl-sulfenamide (C-023)
		0.5	-Dibenzothiazyl disulfide (MBTS) (D-003)
		2.0	- 2-Mercaptobenzothiazole (MBT) (M-003)
		0.5	-2-(4-Morpholinylmercapto)benzothiazol (MOR) (M-016)
Mx-06	ICB-8, IS-21 LA-38, NA-8 NAE-8, NAC-8 AC-15	3.0 pet 1.0 1.0 1.0	Carba mix -1,3-Diphenylguanidine 1.0 D-022 -ZINC DIBUTYLDITHIOCARBAMATE (ZBC) Z-002 -Zinc diethyldithiocarbamate (ZDC) (Z-003)
Mx-07	S-19, ICB-28, IS-12, LA-19 NA-28, NAE-28, NAC-28, ECB-19 AC-6	8.0 pet 1.0 1.0 1.0 1.0 1.0 1.0 1.0	Fragrance mix I ² <small>DO NOT PRELOAD</small> -AMYL CINNAMAL (A-014) -CINNAMYL ALCOHOL (C-013) -CINNAMAL (C-014) -EUGENOL (E-016) -GERANIOL (G-001) -HYDROXYCITRONELLAL (H-008) -ISOEUGENOL (I-002) -Oakmoss absolute (O-001)
Mx-08	<i>Deleted 2021</i>		(Perfume mix ¹)
Mx-09	<i>Deleted 2014</i>		(Wood mix)
Mx-10B	C-55	3.0 pet 1.0 1.0	Musk mix -MUSK KETONE (M-018) -MUSK moskene (M-019)

Art. No.	Serial no.	Conc %(w/w) & Vehicle	Name
		1.0	-MUSK xylene (M-021)
Mx-11	<i>Deleted 2018</i>		(Naphthyl mix)
Mx-12	<i>Deleted 2018</i>		(Caine mix I)
Mx-13	V-19	10.0 pet	Caine mix II
		2.5	-Dibucaine hydrochloride (D-005)
		5.0	-Lidocaine (L-002)
		2.5	-Tetracaine hydrochloride (T-025)
Mx-14	LU-27	12.0 pet	Wood tar mix <small>DO NOT PRELOAD</small>
		3.0	-Beech tar (B-002)
		3.0	-Birch tar (B-011)
		3.0	-Juniperus oxycedrus extract (J-003)
		3.0	-Pine tar (P-012)
Mx-15	PL-12	0.3 pet	Lichen acid mix
		0.1	-Atranorin (A-016)
		0.1	-Evermic acid (E-017)
		0.1	-(+)-Usnic acid (U-005)
Mx-16	ICB-36, TF-12 NAC-36 AC-66	5.0 pet	Ethyleneurea, melamine formaldehyde mix ² <small>DO NOT PRELOAD</small>
		4.0	-Dimethylol dihydroxy ethylene urea (D-012)
		1.0	-Melamine formaldehyde (M-001)
Mx-17D	<i>Deleted 2011</i>		(Euxyl K 400)
Mx-18	S-20, ICB-31, IS-30, ECB-20, LA-20, NA-31 NAE-31, PL-8 NAC-31, AC-57	0.1 pet	Sesquiterpene lactone mix
		0.033	-Alantolactone (A-003)
		0.033	-Costunolide (C-039)
		0.033	-Dehydrocostus lactone (D-056)
Mx-19	ECB-6, LA-6 ME-9, S-6	10.0 pet	Caine mix III
		5.0	-Benzocaine (B-004)
		2.5	-Dibucaine hydrochloride (D-005)
		2.5	-Tetracaine hydrochloride (T-025)
Mx-20	ME-12	10.0 pet	Caine mix IV
		5.0	-Lidocaine (L-002)
		2.5	-Amylocaine hydrochloride (A-020)
		2.5	-Prilocaine hydrochloride (P-027)
Mx-21C	<i>Deleted 2019</i>		(Dermatophagoides mix (Pteronyssinus/ Pharinae 50/50)
Mx-22A	<i>Deleted 2011</i>		(Compositae mix I)
Mx-23	CS-12	2.1 pet	Corticosteroid mix
		1.0	-Hydrocortisone-17-butyrate (H-021)
		1.0	-Tixocortol-21-pivalate (T-031)
		0.1	-Budesonide (B-033)
Mx-24	ICB-24, LA-36 NA-24, NAE-24 NAC-24, AC-41	1.0 pet	Mixed dialkyl thiourea
		0.5	-N,N'-Dibutylthiourea (D-038)
		0.5	-N,N'-Diethylthiourea (D-039)

Art. No.	Serial no.	Conc %(w/w) & Vehicle	Name
Mx-25	S-27, ICB-50, F-31, IS-25, LA-27, NA-32 NAE-32, NAC-50 ECB-27, AC-34	14.0 pet 5.0 2.5 2.5 2.5	Fragrance mix II <small>DO NOT PRELOAD</small> -Hexyl cinnamic aldehyde (H-025) -COUMARIN (C-038) -FARNESOL (F-004) -HYDROXYISOHEXYL 3-CYCLO- HEXENE CARBOXALDEHYDE (L-003)
		1.0	-CITRAL (C-036)
		0.5	-CITRONELLOL (C-037)
Mx-26	ICB-65, TF-33 LA-35, NA-38, NAE-38, NAC-65 AC-35	1.0 pet 0.5 0.5	Disperse Blue mix 106/124 -Disperse Blue 106 (D-040) -Disperse Blue 124 (D-041)
Mx-27	⁶	1.5 pet	Thiourea mix
		0.5	-N,N'-Dibutylthiourea (D-038)
		0.5	-N,N'-Diethylthiourea (D-039)
		0.5	-N,N'-Diphenylthiourea (D-025)
Mx-28	<i>Deleted 2019</i>		(Gallate mix)
Mx-28B	B-20, C-60	1.0 pet	Gallate mix
		0.25	-DODECYL GALLATE (D-042)
		0.5	-PROPYL GALLATE (P-021)
		0.25	-Octyl GALLATE (O-002)
Mx-29A	ICB-66, IS-23 NA-46, NAE-46, NAC-46, AC-65	5.0 pet 1.2 1.2	Compositae mix II <small>DO NOT PRELOAD</small> -Anthemis nobilis extract (C-029) -Chamomilla recutita extract (C-051)
		1.0	-Achillea millefolium extract (A-025)
		1.0	-Tanacetum vulgare extract (T-033)
		0.5	-Arnica montana extract (A-024)
		0.1	-Parthenolide (P-029)
Mx-29B	ECB-35 ⁶	2.5 pet	Compositae mix II <small>DO NOT PRELOAD</small>
		0.6	-Anthemis nobilis extract (C-029)
		0.6	-Chamomilla recutita extract (C-051)
		0.5	-Achillea millefolium extract (A-025)
		0.5	-Tanacetum vulgare extract (T-033)
		0.25	-Arnica montana extract (A-024)
		0.05	-Parthenolide (P-029)
Mx-30	S-30, ICB-48, TF-34, NA-2 NAE-47, NAC-48 ECB-30, IS-14	6.6 pet 1.0 1.0 1.0 1.0 1.0	Textile dye mix -Diperse Blue 35 (D-027) -Diperse Orange 1 (D-031) -DISPERSE ORANGE 3 (D-032) -Disperse Red 1 (D-034) -DISPERSE RED 17 (D-035) -Disperse Yellow 3 (D-036) -Disperse Blue 106 (D-040) -Disperse Blue 124 (D-041)

Art. No.	Serial no.	Conc %(w/w) & Vehicle	Name
Mx-31	6	7.0 pet	Caine mix V
		5.0	-Benzocaine (B-004)
		1.0	-Dibucaine hydrochloride (D-005)
		1.0	-Tetracaine hydrochloride (T-025)
N-001	S-4, ICB-9, IS-2 LA-4, NA-9, NAE-9, NAC-9, ECB-4, AC-3	20.0 pet	Neomycin sulfate
N-002A	S-7, H-7, SH-10, DS-15, DMP-15 LA-7, ECB-7, MET-36	5.0 pet	Nickel(II)sulfate hexahydrate
N-002B	ICB-20, IS-13 NA-20, NAE-20, NAC-20, AC-1	2.5 pet	Nickel(II)sulfate hexahydrate
N-003	<i>Deleted 2015</i>		(SOLVENT BLACK 5)
N-004	H-3	1.0 pet	2-NITRO-p-PHENYLENEDIAMINE
N-005	ME-6, LU-5	1.0 pet	Nitrofurazone
N-006	F-9	2.0 pet	Narcissus poeticus absolute <small>DO NOT PRELOAD</small>
N-007	CAD-12	10.0 pet	Norfloxacin
N-008	MET-50	0.2 pet	Niobium(V)chloride
O-001	F-7	2.0 pet	Oakmoss absolute ² <small>DO NOT PRELOAD</small>
O-002	B-14, C-8	0.25 pet	Octyl gallate
O-003	<i>Deleted 2021</i>		(Oligotriacrylate (OTA 480))
O-004	O-33, SH-22, PG-23, ICB-64 NAC-64, ECB-41	0.1 pet	2-n-Octyl-4-isothiazolin-3-one <small>DO NOT PRELOAD</small>
O-005	ICB-80, C-56, H-28, NA-48, NAE-48, NAC-80, AC-44	0.1 aq	OLEAMIDOPROPYL DIMETHYLAMINE <small>DO NOT PRELOAD</small>
O-006	<i>Deleted 2017</i>		(OLEA EUROPAEA OIL)
O-007A	ICB-73, SU-13 NAC-73	5.0 pet	ETHYLHEXYL SALICYLATE
O-007B	EPE-24	10.0 pet	ETHYLHEXYL SALICYLATE
O-008	EPE-33	1.0 pet	Olaquinox
O-009	SU-12, EP-5, EPE-5	10.0 pet	OCTOCRYLENE
O-010	SU-14, EP-13, EPE-13	10.0 pet	ETHYLHEXYL TRIAZONE
P-001	DS-23, DMP-19, MET-7	2.0 pet	Palladium(II)chloride
P-002	<i>Deleted 2021</i>		(Pentaerythritol triacrylate)

Art. No.	Serial no.	Conc %(w/w) & Vehicle	Name
P-003	V-5	100	PETROLATUM
P-004	<i>Deleted 2018</i>		(1-Phenyl-3-pyrazolidinone)
P-005	PG-12, IS-26	1.0 pet	Phenol formaldehyde resin (PFR2) <small>DO NOT PRELOAD</small>
P-006	S-2, H-1, ICB-4, SH-9, IS-4, LA-2 NA-4, NAE-4, NAC-4, ECB-2, AC-20	1.0 pet	p-PHENYLENEDIAMINE (PPD)
P-007	PG-17	2.0 pet	2-Phenylindole
P-008	C-18, LU-23, MET-30	0.01 aq	PHENYL MERCURIC ACETATE <small>DO NOT PRELOAD</small>
P-009	R-16	1.0 pet	N-Phenyl-2-naphtylamine (PBN)
P-010	O-5	1.0 pet	o-PHENYLPHENOL
P-011	C-24, PG-3	1.0 pet	PHENYL SALICYLATE
P-012			Only available as part of Mx-14 (Pine tar)
P-013	ICB-62, C-4, NAC-62	5.0 pet	POLYSORBATE 80
P-014A	S-1, DS-10, SH-7, P-14, IS-1, DMP-1, LA-1, ECB-1, MET-55	0.5 pet	Potassium dichromate
P-014B	ICB-18, NA-18, NAE-18, NAC-18, AC-4	0.25 pet	Potassium dichromate
P-015	MET-31	0.1 aq	Potassium dicyanoaurate(I) <small>DO NOT PRELOAD</small>
P-016	V-15	1.0 pet	Procaine hydrochloride
P-017A	<i>Deleted 2019</i>		(Promethazine hydrochloride)
P-017B	<i>Deleted 2021</i>		(Promethazine hydrochloride)
P-018	B-13	3.0 pet	PROPIONIC ACID <small>DO NOT PRELOAD</small>
P-019A	C-27, O-6, LU-11	5.0 pet	PROPYLENE GLYCOL ³ <small>DO NOT PRELOAD</small>
P-019B	ICB-79, NA-33, NAE-33, NAC-79, AC-37	30.0 aq	PROPYLENE GLYCOL <small>DO NOT PRELOAD</small>
P-019C	<i>Deleted 2017</i>		(PROPYLENE GLYCOL)
P-020	<i>Deleted 2021</i>		(PROPYLPARABEN)
P-021	B-18, C-38, LA-32	1.0 pet	PROPYL GALLATE
P-022	ECB-22, ICB-33, NA-35, NAE-61, NAC-33, LU-12, PL-6, AC-53	10.0 pet	Propolis
P-023	E-4	0.25 pet	2-Phenyl glycidyl ether <small>DO NOT PRELOAD</small>
P-024B	SU-9, EPE-22	10.0 pet	PHENYLBENZIMIDAZOLE SULFONIC ACID
P-025	C-41, O-32, AC-75	1.0 pet	PHENOXYETHANOL <small>DO NOT PRELOAD</small>
P-026	ME-21, AC-39	5.0 pet	Polymyxin B sulfate

Art. No.	Serial no.	Conc %(w/w) & Vehicle	Name
P-027A	V-1	5.0 pet	Prilocaine hydrochloride
P-028	<i>Deleted 2018</i>		(p-PHENYLENEDIAMINE HCL)
P-029	PL-13	0.1 pet	Parthenolide
P-030	<i>Deleted 2014</i>		(Phosphorus sesquisulfide)
P-031	<i>Deleted 2018</i>		(Penicillin G, potassium salt)
P-032	<i>Deleted 2021</i>		(Pristinamycin)
P-033	CAD-21, EP-17, EPE-17	1.0 pet	Piroxicam
P-034	⁶	100	Polyethylene glycol 400 (PEG 400)
P-035	EPE-25	10.0 pet	Polysilicone-15
P-036	C-50, AC-86	2.0 pet	Peppermint oil <small>DO NOT PRELOAD</small>
P-038	I-7	2.0 pet	Polymeric diphenylmethane diisocyanate (PMDI) <small>DO NOT PRELOAD</small>
P-039	ME-18, AC-87	2.0 pet	Pramoxine hydrochloride
P-040	CAD-35	10.0 pet	Potassium clavulanate
P-041	ME-19	10.0 pet	Phenylbutazone
P-042	C-62, H-38	5.0 pet	PANTHENOL
P-043	C-63	2.5 aq	POLYAMINOPROPYL BIGUANID <small>DO NOT PRELOAD</small>
Q-001	ME-3	1.0 pet	Quinine sulfate
R-001	H-9	1.0 pet	RESORCINOL
R-002	PG-16	1.0 pet	Resorcinol monobenzoate
R-003	F-20	2.0 pet	Rose absolute <small>DO NOT PRELOAD</small>
R-004B	TF-22	1.0 pet	Reactive Black 5
R-005B	TF-23	1.0 pet	Reactive Blue 21
R-006B	<i>Deleted 2016</i>		(Reactive Blue 238)
R-007B	TF-25	1.0 pet	Reactive Orange 107
R-008B	TF-26	1.0 pet	Reactive Red 123
R-009B	<i>Deleted 2018</i>		(Reactive Red 238)
R-010B	TF-28	1.0 pet	Reactive Red 228
R-011B	TF-29	1.0 pet	Reactive Violet 5
R-012	MET-45	0.1 pet	Ruthenium
R-013	MET-53	2.0 pet	Rhodium(III)chloride hydrate
S-001	B-4, AC-62	5.0 pet	SODIUM BENZOATE
S-002	C-32, O-28	0.1 aq	Sodium-2-pyridinethiol-1-oxide <small>DO NOT PRELOAD</small>
S-003	B-11, C-10, LU-14 AC-63	2.0 pet	SORBIC ACID
S-004	C-5, LU-22	5.0 pet	SORBITAN OLEATE
S-005	C-26, LU-20 AC-67	20.0 pet	SORBITAN SESQUIOLEATE

Art. No.	Serial no.	Conc %(w/w) & Vehicle	Name
S-006	C-28	30.0 pet	STEARYL ALCOHOL
S-007	MET-32	1.0 aq	SILVER NITRATE <small>DO NOT PRELOAD</small>
S-008	F-48	2.0 pet	Styrax <small>DO NOT PRELOAD</small>
S-009	F-24	2.0 pet	Sandalwood oil <small>DO NOT PRELOAD</small>
S-010	ME-4	5.0 pet	Sulfanilamide
S-011	C-59, H-37 ECB-31	1.0 pet	SODIUM METABISULFITE
S-012	CAD-8	10.0 pet	Spiramycin base
S-013	MET-39	1.0 pet	STANNOUS CHLORIDE
S-014	MET-26	1.0 pet	Tin(II)oxalate
S-015	C-51, AC-88	20.0 alc	SHELLAC <small>DO NOT PRELOAD</small>
S-016	V-30	100	Softisan 649
S-017	DMP-24, DS-31, MET-43, LA-33	3.0 pet	Sodium tetrachloropalladate(II) hydrate
S-018	V-36	0.25 aq	SODIUM LAURYL SULFATE <small>DO NOT PRELOAD</small>
S-019	MET-46	2.0 aq	Sodium tungstate dihydrate <small>DO NOT PRELOAD</small>
T-001	<i>Deleted 2018</i>		(3,3',4',5-Tetrachlorosalicylanilide (TCS))
T-002	R-3	1.0 pet	Tetraethylthiuram disulfide (TETD)
T-003	<i>Deleted 1999</i>		(Tetramethylol acetylenediurea)
T-004	<i>Deleted 2014</i>		(3,3',5,5'-Tetramethylbenzidine)
T-005	R-1	1.0 pet	Tetramethylthiuram disulfide (TMTD)
T-006	R-2	1.0 pet	Tetramethylthiuram monosulfide (TMTM)
T-007	ICB-32, C-13, O-22, LU-13, LA-34, NAC-32	0.1 pet	THIMEROSAL
T-008	DS-30, MET-12	50.0 pet	Tin
T-009	I-1	2.0 pet	Toluene-2,4-diisocyanate (TDI) <small>DO NOT PRELOAD</small>
T-010	ICB-41, PG-15, LA-29, NA-41, NAE-41, NAC-41, AC-56	10.0 pet	Toluenesulfonamide formaldehyde resin
T-011	DS-20	2.0 pet	4-Tolyldiethanolamine
T-012	<i>Deleted 2021</i>		(3,4,5-Tribromosalicylanilide (TBS))
T-013	O-24, EPE-20	1.0 pet	TRICLOCARBAN
T-014	C-9, O-18, EPE-28	2.0 pet	TRICLOSAN
T-015	PG-11, P-16	5.0 pet	Tricresyl phosphate
T-016	ICB-47, C-3, O-7, LU-18,	2.0 pet	TRIETHANOLAMINE

Art. No.	Serial no.	Conc %(w/w) & Vehicle	Name
	NAC-47		
T-017	MN-13, MP-23	0.1 pet	Triethylene glycol diacrylate <small>DO NOT PRELOAD</small>
T-018	DS-2, MA-6, MN-7, MP-11, DMP-2, DMS-2	2.0 pet	Triethylene glycol dimethacrylate
T-019	E-3	0.5 pet	Triethylenetetramine (TETA) <small>DO NOT PRELOAD</small>
T-020	R-21	1.0 pet	2,2,4-Trimethyl-1,2-dihydroquinoline
T-021	MN-9, MP-17	0.1 pet	Trimethylolpropane triacrylate <small>DO NOT PRELOAD</small>
T-022	PG-14	5.0 pet	Triphenyl phosphite
T-023	MP-16	0.1 pet	Tri(propylene glycol) diacrylate <small>DO NOT PRELOAD</small>
T-024A	<i>Deleted 2011</i>		(Turpentine peroxides)
T-024B	C-53	0.4 pet	Turpentine oil oxidized <small>DO NOT PRELOAD</small>
T-025A	V-22	5.0 pet	Tetracaine hydrochloride
T-026	R-26	0.1 pet	Thiourea
T-027	DS-29, MA-12, MN-10, DMP-8, DMS-6	2.0 pet	Tetrahydrofurfuryl methacrylate <small>DO NOT PRELOAD</small>
T-028	PG-25	0.5 pet	Triglycidyl isocyanurate, (TGIC)
T-029	MA-13	2.0 pet	Tetraethylene glycol dimethacrylate
T-030	CS-3, AC-71	1.0 pet	Triamcinolone acetonide
T-031A	ICB-44, NA-44 NAE-44, NAC-44, AC-27	1.0 pet	Tixocortol-21-pivalate
T-031B	S-25, IS-19, CS-4, LU-21, LA-25, ECB-25	0.1 pet	Tixocortol-21-pivalate
T-032	PL-4	2.5 pet	Taraxacum officinale extract <small>DO NOT PRELOAD</small>
T-033	PL-10	1.0 pet	Tanacetum vulgare extract <small>DO NOT PRELOAD</small>
T-034	ME-14	1.0 pet	Tioconazole
T-035B	ICB-49, C-46 NAE-64, NAC-49, AC-51	5.0 pet	Tea tree oil oxidized <small>DO NOT PRELOAD</small>
T-036	ICB-22, C-43 NAE-60, NAC-22, AC-49	100	TOCOPHEROL <small>DO NOT PRELOAD</small>
T-037B	C-52	10.0 pet	TOCOPHERYL ACETATE
T-038	<i>Deleted 2021</i>		(Trimethylolpropane triglycidyl ether)
T-039	MET-16	5.0 pet	Titanium(III)nitride
T-040	MET-17	10.0 pet	TITANIUM DIOXIDE
T-041	MET-19	5.0 pet	Titanium(IV)oxalate hydrate
T-042	MET-21	10.0 pet	Titanium
T-043	MET-28	5.0 pet	Tungsten
T-044	<i>Deleted</i>		

Art. No.	Serial no.	Conc %(w/w) & Vehicle	Name
T-045	<i>Deleted</i>		(Terephthalylidene dicamphor sulphonc acid (Mexoryl SX))
T-046	<i>Deleted</i>		(Turpentine peroxides)
T-047	MET-51	1.0 pet	Tantalum
T-048	E-15	0.5 pet	2,4,6-Tris(dimethylaminomethyl)phenol <small>DO NOT PRELOAD</small>
T-049	H-30	1.0 pet	TOLUENE-2,5-DIAMINE ³
T-050	ME-15	20.0 pet	Tobramycin
U-001	TF-13	10.0 pet	Urea formaldehyde resin
U-002	<i>Deleted 2019</i>		(Urethane diacrylate, aliphatic)
U-003	<i>Deleted 2019</i>		(Urethane diacrylate, aromatic)
U-004	DS-3, MA-8	2.0 pet	Urethane dimethacrylate <small>DO NOT PRELOAD</small>
U-005	PL-15	0.1 pet	(+)-Usnic acid
V-001	B-1, F-17	10.0 pet	VANILLIN
V-002	MET-22	5.0 pet	Vanadium
V-003	MET-24	1.0 pet	Vanadium(III)chloride
V-004	ME-16	10.0 aq	Vancomycin hydrochloride <small>DO NOT PRELOAD</small>
V-005	MET-47	10.0 pet	Vanadium(V)oxide
W-001	S-12, IS-8, LA-12, ECB-12	30.0 pet	LANOLIN ALCOHOL
X-001	E-13	0.1 pet	m-Xylylenediamine <small>DO NOT PRELOAD</small>
Y-001	ICB-57, F-21 NA-16, NAE-65, NAC-57, AC-64	2.0 pet	Ylang ylang oil <small>DO NOT PRELOAD</small>
Z-001	MET-1	2.5 pet	Zinc
Z-002	R-14	1.0 pet	ZINC DIBUTYLDITHIOCARBAMATE (ZBC)
Z-003	R-13	1.0 pet	Zinc diethyldithiocarbamate (ZDC)
Z-004	R-20	1.0 pet	Zinc dimethyldithiocarbamate (Ziram)
Z-005	O-17	1.0 pet	Zinc ethylenebis-(dithiocarbamate) (Zineb)
Z-006	H-25	1.0 pet	ZINC PYRITHIONE
Z-007A	<i>Deleted 2011</i>		(ZINC CHLORIDE)
Z-007B	MET-18	1.0 pet	ZINC CHLORIDE
Z-008	MET-27	1.0 pet	Zirconium(IV)chloride
Z-009	MET-52	0.1 pet	ZIRCONIUM DIOXIDE

Abbreviations in Hapten Information

- CAS:** Chemical Abstract Service (CAS) registry numbers.
Cross: Antigens mentioned are primary sensitizers to which the compound might crossreact. For further information visit www.contactderm.org.
FW: Formula weight.
ICU: Immunologic Contact Urticaria.
INCI: International Nomenclature of Cosmetic Ingredients, names displayed in Capitals in accordance to EUR-Lex 2006/257/EG. All the haptens with INCI names are written in capital letters throughout the catalogue.
NSAID: Non-steroidal anti-inflammatory drug
NICU: Nonimmunologic contact urticaria.
PA: Compound that may cause photoallergic reactions.
PL: Compound that may cause persistent light reactions.
PT: Compound that may cause phototoxic reactions.
UCU: Uncertain mechanism type contact urticaria.

DO NOT RELOAD Volatile hapten, not recommended for preloading

- ¹ Also present in European Baseline Series
² Emulsifier: SORBITAN SESQUIOLEATE 5%
³ Emulsifier: SORBITAN SESQUIOLEATE 1%
⁴ Emulsifier: SORBITAN SESQUIOLEATE 2%
⁵ Contains DECYL GLUCOSIDE
⁶ Present in national series. Visit www.chemotechnique.se for further information.
^{EC} Directive 2003/15/EC relating to cosmetic products

Hapten Information

Art. No.	Formula	FW	Series
----------	---------	----	--------

A

ABIETIC ACID

A-001	$C_{20}H_{30}O_2$	302.44	O
-------	-------------------	--------	---

Component in tall oil used as deodorizing agent in cooling fluids. Major component of rosin used in adhesive tapes, glues, inks, sealants, cosmetics, dental impression materials. **Cross: COLOPHONIUM, dihydroabietyl alcohol.** CAS 514-10-3.

ACETAMINOPHEN

A-032	$C_8H_9NO_2$	151.16	CAD
-------	--------------	--------	-----

Paracetamol or acetaminophen, is the active metabolite of phenacetin, a so-called coal tar analgesic. It is an effective substitute for acetylsalicylic acid, due to its analgesic (to relieve minor aches and pains) and antipyretic (to reduce fever) properties. However, unlike aspirin, it is not a very effective anti-inflammatory agent though it lacks many of the side effects of aspirin, and is available over-the-counter. Paracetamol is also useful in the management of more severe pain, where it allows lower dosages of additional non-steroidal anti-inflammatory drugs (NSAIDs) or opioid analgesics to be used, thereby minimizing overall side effects. It is a major ingredient in numerous cold and flu medications. **CAS** 103-90-2.

Acetylsalicylic acid

A-031	$C_9H_8O_4$	180.16	CAD
-------	-------------	--------	-----

Aspirin[®], or acetylsalicylic acid, (acetosal) is a salicylate drug often used as an analgesic, antipyretic, and as an anti-inflammatory. It also has an antiplatelet ("blood-thinning") effect and is used long-term in low doses to prevent heart attacks and blood clot formation in people at high risk for developing blood clots. **CAS** 50-78-2.

Art. No.	Formula	FW	Series
----------	---------	----	--------

Achillea millefolium extract

A-025			PL
-------	--	--	----

Perennial compositae weed with white flowers. Grows in most of Europe and in N. America, New Zealand and southern Australia. The raw material for this product is made from an ethanol extraction of the plant/flowers of Achillea Millefolium. Contains the sesquiterpene lactone -peroxyachifolide. Also known as Yarrow. Also available as part of Mx-29A and Mx-29B. **May cause airborne contact dermatitis.**

Acid Yellow 36

A-019	$C_{18}H_{14}N_3NaO_3S$	375.38	SH
-------	-------------------------	--------	----

Dye used in leather. As indicator (pH) in laboratories. **CAS** 587-98-4.

Acid Yellow 61

A-026			TF
-------	--	--	----

Azo dye belonging to the acid dye class for coloring wool and polyamide textiles. **CAS** 12217-38-8

Acid Red 118

A-027			TF
-------	--	--	----

Azo dye belonging to the acid dye class for coloring wool and polyamide textiles.

Acid Red 359

A-028			TF
-------	--	--	----

Azo dye (chrome) belonging to the premetallic dye class for coloring wool and polyamide textiles. **CAS** 61814-65-1.

Acyclovir

A-033	$C_8H_{11}N_5O_3$	225.21	CAD
-------	-------------------	--------	-----

Aciclovir, chemical name acycloguanosine, is a guanine analogue antiviral drug, marketed under trade names such as Zovirax and Zovir. One of the most commonly-used antiviral drugs, it is primarily used for the treatment of herpes simplex virus infections, as well as in the treatment of herpes zoster (shingles). **CAS** 59277-89-3.

Art. No.	Formula	FW	Series
----------	---------	----	--------

Alantolactone

A-003	$C_{15}H_{20}O_2$	232.31	S, ICB, IS, PL
-------	-------------------	--------	----------------

Sesquiterpene lactone present in, e.g., species of Chrysanthemum plants (Helenin). Also available as part of Mx-18. **CAS** 546-43-0.

Alclometasone-17, 21-dipropionate

A-023	$C_{28}H_{37}ClO_7$	520.71	CS
-------	---------------------	--------	----

Topical non-fluorinated corticosteroid with low systemic effects. **CAS** 66734-13-2.

Aluminium

Deleted 2017

Please refer to Aluminium(III)chloride hexahydrate (A-022) or ALUMINUM HYDROXIDE (A-038).

Aluminium(III)chloride hexahydrate

A-022	$AlCl_3 \cdot 6H_2O$	241.43	DS, MET
-------	----------------------	--------	---------

This hapten is a marker for contact allergy to **aluminum**. Used in preserving wood, disinfecting stables, etc., in deodorants and antiperspirant preparations. Used in refining crude oil, dyeing fabrics. Found in dental ceramics and topical astringents. **CAS** 7784-13-6

ALUMINUM HYDROXIDE

A-038	$Al(OH)_3$	78.0	MET
-------	------------	------	-----

This hapten is a marker for contact allergy to **aluminum**. Most of this chemical is converted to aluminium oxide (alumina) that is used in the manufacture of aluminium metal. The chemical is also used as a fire retardant filler, producing water vapor and smoke suppressant for polymer applications. The gel form of the chemical is applied to make aluminium salts as flocculants in water purification.

The substance is also used as an antacid, to treat/control, or manage high levels of phosphate in the body. In addition it is also used with a low phosphate diet to prevent the formation of phosphate urinary stones. It can also be found in personal care products. Aluminum can in different forms be found in dental implants. **CAS** 21645-51-2

Art. No.	Formula	FW	Series
Amerchol L-101			
A-004			ICB, C, O, LU, AC,NA,NAE,NAC

Trade name of product containing lanolin alcohols obtained from hydrolysis of lanolin. Emulsifier and emollient in cosmetic and pharmaceutical bases, topical drugs, furniture polish, leather, metal corrosion prevention, paper, inks, textiles, furs, cutting oils, waxes. **UCU.**

Amidoamine

A-029			ICB, NA, NAE, NAC, AC
-------	--	--	--------------------------

Amidoamines are a class of chemical compounds used as intermediates in the synthesis of surfactants, such as cocamidopropylbetaine (CAPB), some of which are used in personal care products including soaps, shampoos, and cosmetics. Amidoamines are amides formed from fatty acids and diamines. Studies have concluded that most apparent allergic reactions to products containing CAPB are more likely due to amidoamine.

4-Aminoazobenzene

A-005	$C_{12}H_{11}N_3$	197.24	SH
-------	-------------------	--------	----

Intermediate in the production of diazo dyes. Pigment in, e.g., plastic materials. Also known as Solvent yellow 1. **Cross: para group of compounds. CAS 60-09-3.**

4-AMINO-2-HYDROXYTOLUENE

A-039	$H_2NC_6H_3(CH_3)OH$	123.15	H
-------	----------------------	--------	---

This substance is typically used in the formulation of hair dyes and colors. **CAS 2835-95-2**

m-AMINOPHENOL

A-008	C_6H_7NO	109.13	H
-------	------------	--------	---

Used as a coupler for hair dyes. Found as dye intermediate. Used in the manufacturing of 4-amino salicylic acid. **Cross: para group of compounds. CAS 591-27-5.**

Art. No.	Formula	FW	Series
p-AMINOPHENOL			
A-009	C_6H_7NO	109.13	H

Primary intermediate for hair dyes. Photographic developer. Dye for furs and feathers. **Cross: para group of compounds. CAS 123-30-8.**

Ammonium hexachloroiridate(IV)

A-034	$H_8Cl_6IrN_2$	441.01	MET
-------	----------------	--------	-----

This hapten is a marker for contact allergy to **iridium**. Ammonium hexachloroiridate (IV) is used in the production of photographic emulsions and in catalytic composites in the process of converting hydrocarbons. **CAS 16940-92-4.**

Ammonium hexachloroplatinate(IV)

A-010	$Cl_6H_8N_2Pt$	443.88	MET
-------	----------------	--------	-----

This hapten is a marker for contact allergy to **platinum**. Precious metal salt which is used in platinum plating. **ICU. CAS 16919-58-7.**

Ammonium molybdate (VI) tetrahydrate

A-035	$H_{24}Mo_7N_6O_{24} \cdot 4H_2O$	1235.86	MET
-------	-----------------------------------	---------	-----

This hapten is a marker for contact allergy to **molybdenum**. Ammonium Molybdate is an odourless crystalline compound ranging in colour from white to yellow-green. It is also called molybdic acid hexammonium salt tetrahydrate, ammonium molybdate tetrahydrate, and ammonium heptamolybdate tetrahydrate. Used as an analytical reagent to find the presence of phosphates, silicates, arsenates and lead in pigments. Used in the production of molybdenum metal and ceramics, in the fixing of metals and in electroplating, in fertilizers for crops and as a negative stain in biological electron microscopy. **CAS 12054-85-2.**

AMMONIUM PERSULFATE

A-011	$H_8N_2O_8S_2$	228.20	B, H
-------	----------------	--------	------

Found in hair bleaches as oxidizer and bleacher. Used in decolorizing and deodorizing oils, electroplating, making starch soluble, yeast treatment. Used as reducer and retarder in photography. **May cause airborne contact dermatitis. UCU. CAS 7727-54-0.**

Art. No.	Formula	FW	Series
AMMONIUM THIOGLYCOLATE			
A-012	C ₂ H ₇ NO ₂ S	109.15	H

Acts as reducing agent in permanent waving formulations for hair treatment. **CAS** 5421-46-5.

Ammonium tetrachloroplatinate(II)

A-013	Cl ₄ H ₈ N ₂ Pt	372.98	MET
-------	--	--------	-----

This hapten is a marker for contact allergy to **platinum**. Precious metal salt which is used in photography. **ICU. CAS** 13820-41-2.

Amoxicillin trihydrate

A-030	C ₁₆ H ₁₉ N ₃ O ₅ S	365.40	CAD
-------	---	--------	-----

Amoxicillin or amoxycillin is a moderate-spectrum β-lactam antibiotic used to treat bacterial infections caused by susceptible microorganisms. It is usually the drug of choice within the class because it is better absorbed, following oral administration, than other beta-lactam antibiotics. Amoxicillin is susceptible to degradation by β-lactamase-producing bacteria, and so may be given with clavulanic acid to decrease its susceptibility. Is currently marketed by GlaxoSmithKline (the inheritor company) under the original trade name Amoxil. **CAS** 61336-70-7.

AMYL CINNAMAL

A-014	C ₁₄ H ₁₈ O	202.30	F
-------	-----------------------------------	--------	---

Raw material in the production of perfumes. Also known as Amylcinnamaldehyde. Also available as part of Mx-07. **Cross: amylcinnamic alcohol. CAS** 122-40-7.

Amyl cinnamyl alcohol

A-036	C ₁₄ H ₂₀ O	204.31	F
-------	-----------------------------------	--------	---

Amyl cinnamyl alcohol is one of many ingredients in fragrances. It is found in soaps, detergent, beauty care products and household products. **CAS** 101-85-9.

Art. No.	Formula	FW	Series
Amylocaine hydrochloride			
Deleted 2021	C ₁₄ H ₂₂ ClNO ₂	271.80	

Used as a topical and local anesthetic agent. Also available as part of Mx-20. **Cross: Tetracaine. CAS** 532-59-2.

TRANS-ANETHOLE

A-015	C ₁₀ H ₁₂ O	148.21	B
-------	-----------------------------------	--------	---

Used as flavoring agent in food, dentifrices, pharmaceuticals etc. In perfumery for soap, etc. In photography and in embedding materials in microscopy. **CAS** 4180-23-8.

Anise alcohol

A-037	C ₈ H ₁₀ O ₂	138.16	F
-------	---	--------	---

Anise alcohol (2-Methoxybenzyl alcohol) is one of many ingredients in fragrances. It is found in soaps, detergents, beauty care products and household products. **CAS** 105-13-5.

Anthemis nobilis extract

C-029			PL
-------	--	--	----

Compositae plant growing in most of Europe, in N.Africa, S.America, Australia and New Zealand. A yellow dye is extracted from the dried flowers and is sometimes used in shampoos, hair rinses and ointments. Anaphylactic reaction following ingestion of camomile tea has been reported. The raw material for this product is made from an ethanol extraction of the plant/flowers of Anthemis nobilis. May be referred to as Chamomilla Romana. Also available as part of Mx-29A and Mx-29B.

Arnica montana extract

A-024			PL
-------	--	--	----

Compositae plant that grows on prairies and in mountainous lands in Europe, and Asia. Tincture of arnica is used in trauma treatment. The raw material for this product is made from an ethanol extraction of the plant/flowers of Arnica Montana. Major haptens appear to be helenalin and its esters. Also available as part of Mx-29A and Mx-29B. **Cross: a number of other Asteraceae plants.**

Art. No.	Formula	FW	Series
Atranorin			
A-016	C ₁₉ H ₁₈ O ₈	374.33	PL

One of the most common substances found in lichens. Component in extracts of oak moss used as fragrance. Also available as part of Mx- 15. **Cross: oakmoss. PA. CAS** 479-20-9

Azodiisobutyrodinitrile

Deleted 2021	C ₈ H ₁₂ N ₄	164.21	
--------------	---	--------	--

Foaming agent and inhibitor in plastic and elastomer materials. **CAS** 78-67-1.

B

Bacitracin

B-032	C ₆₆ H ₁₀₃ N ₁₇ O ₁₆ S	1421.79	ME, LU, NA, NAE, NAC, AC
-------	--	---------	-----------------------------

Antibiotic agent effective against gram-positive organisms and spirochetes. In products for topical treatment, ear medications, and ophthalmic drugs. Common hapten in leg ulcer treatment. **Cross: polymyxin B sulfate, neomycin sulfate. ICU. CAS** 1405-87-4.

Balsam Peru

Change of name as of January 2016; please refer to Peru balsam (Art. No. B-001).

Basic Red 46

B-026			TF
-------	--	--	----

Monoazo dye used for acrylic and polyester textiles (sweaters, etc.).

Beech tar

Used in tar paper, insulation tapes and topical medicaments. Also known as FAGUS SYLVATICA. Available as part of Mx-14.

Art. No.	Formula	FW	Series
BENZALKONIUM CHLORIDE			
B-027	C ₁₇ H ₃ OCIN	283.88	ICB, LU, AC

Topical quaternary ammonium antiseptic agent found in ophthalmic (eye) preparations, skin disinfectants, cosmetics, deodorants, mouthwashes, dentifries, sterilization solutions, lozenges, and solutions for contact lenses. **Cross: cetrimoniumbromide, benzethoniumchloride. May cause airborne contact dermatitis. CAS** 63449-41-2

BENZISOTHIAZOLINONE

B-003	C ₇ H ₅ NOS	151.19	ECB, O
-------	-----------------------------------	--------	--------

Preservative used in cooling fluids, paints, adhesives paper and in the textile industry . Also known as BIT. **CAS** 2634-33-5.

Benzocaine

B-004	C ₉ H ₁₁ NO ₂	165.19	S, ICB, ME, NA, NAE, NAC, AC
-------	--	--------	---------------------------------

Local and topical anesthetic used in products such as burn and sunburn remedies, hemorrhoidal creams, suppositories, creams for treatment of poison ivy, oral and gingival products, sore throat sprays/lozenges, astringents, appetite suppressants. Also known as Ethyl 4-aminobenzoate. Also available as part of Mx-19 and Mx-31. **Cross: para group of compounds, butethamine, procainamide, hydrochlorothiazide, PABA and esters, azo/aniline dyes, PPD, sulfonamides, sulfonyleureas, 4-aminosalicylic acid, parabens. PA. UCU. CAS** 94-09-7.

BENZOIC ACID

B-005	C ₇ H ₆ O ₂	122.12	B, AC
-------	--	--------	-------

Used in preserving foods, fats, fruit juices, etc (it and its salt is represented by E-numbers E210, E211, E212, and E213). Also used as an antifungal agent in pharmaceutical preparations and cosmetics. **Cross: Peru balsam. ICU. CAS** 65-85-0

Art. No.	Formula	FW	Series
BENZOPHENONE-3 H-014	$C_{14}H_{12}O_3$	228.24	ICB, C, DS, EP, EPE, SU, NAE, NAC, AC

Common UV-adsorber in dental composite materials and other plastic materials. Used as a UV-adsorber in topical sunscreens, moisturizers, shampoos, hair care products, lipsticks, lip balms, nail polish, etc. Also known as 2-Hydroxy-4-methoxybenzophenone, Eusolex 4360, Escalol 567, Oxybenzone. **Cross: dioxybenzone. PA. CAS** 131-57-7.

Art. No.	Formula	FW	Series
BENZOPHENONE-4 H-023	$C_{14}H_{12}O_6S$	308.31	SU, EP, EPE, AC

Sunscreen for use in various sunscreen products as well as in textiles, plastics, paints and cosmetics. Also known as 2-Hydroxy-4-methoxy-benzophenone-5-sulfonic acid, Sulisobenzene and Uvinul MS-40. **CAS** 4065-45-6.

Art. No.	Formula	FW	Series
BENZOPHENONE-10 H-020	$C_{15}H_{14}O_3$	242.26	SU, EPE

UV absorbing agent in sunscreen cosmetics of the type creams, lotions, lipsticks, sun oils, etc. Also known as 2-Hydroxy-4-methoxy-4'-methylbenzophenone, Mexenone. **Cross (photo): BENZOPHENONE-3. PA. CAS** 1641-17-4

Art. No.	Formula	FW	Series
BENZOTRIAZOLE B-006	$C_6H_5N_3$	119.13	O, P

Anticorrosive agent in cooling fluids fuels, photographic development, antifreeze, dry cleaning, etc. Also known as 1H-Benzotriazole. **CAS** 95-14-7.

Art. No.	Formula	FW	Series
Benzoylperoxide B-007	$C_{14}H_{10}O_4$	242.23	ICB, B, PG, LU NAC

Used as initiator in the polymerization of plastics, as oxidizer in bleaching oils, flour etc. Is a keratolytic agent in acne medications. **May cause discoloration of the hair and postinflammatory pigmentation and hypopigmentation. May cause airborne contact dermatitis. UCU. CAS** 94-36-0.

Art. No.	Formula	FW	Series
Benzylamine hydrochloride B-041	$C_{19}H_{23}N_3O \cdot HCl$	345.87	EP, EPE

Benzylamine hydrochloride is a NSAID, with local anesthetic and analgesic properties for pain relief and anti-inflammatory treatment of inflammatory conditions of the mouth and throat. **CAS** 132-69-4

Art. No.	Formula	FW	Series
BENZYL ALCOHOL B-008	C_7H_8O	108.13	ICB, C, F, P; NAE, NAC, AC

Solvent in photography, perfumery and for dyestuffs, inks, pharmaceutical products, etc. Used as preservative in injectable drugs, ophthalmic solutions, and oral liquids. **Cross: Peru balsam, benzoin tincture. May cause pigmentation of the face. ICU. CAS** 100-51-6.

Art. No.	Formula	FW	Series
BENZYL BENZOATE B-038	$C_{14}H_{12}O_2$	212.24	F

Benzyl benzoate is the ester of BENZYL ALCOHOL and BENZOIC ACID. This easily prepared compound has a variety of uses. Benzyl benzoate, as a topical solution, may be used as an antiparasitic insecticide to kill lice and the mites responsible for the skin condition scabies. It has other uses such as a fixative in fragrances to improve the stability and other characteristics of the main ingredients; a food additive in artificial flavors; a plasticizer in cellulose and other polymers; a solvent for various chemical reactions; a treatment for sweet itch in horses. **CAS** 120-51-4.

Art. No.	Formula	FW	Series
BENZYL CINNAMATE B-039	$C_{16}H_{14}O_2$	238.29	F

Used as flavoring agent (sweet, floral, fruity) and as a perfumery fixer. **CAS** 103-41-3

Art. No.	Formula	FW	Series
BENZYL SALICYLATE B-010	$C_{14}H_{12}O_3$	228.26	ICB, C, F, NAC

Used as organic solvent for perfumes, also found in tanning creams and lotions. **May cause pigmentation of the face. CAS** 118-58-1.

Art. No.	Formula	FW	Series
Beryllium(II)sulfate tetrahydrate			
B-044	BeSO ₄ · 4H ₂ O	177.14	MET

This hapten is a marker for contact allergy to **beryllium**. Beryllium improves many physical properties when added as an alloying element to aluminum, copper, iron and nickel. It can be found in tools and in the aerospace industry where it is used for aircraft components, missiles, spacecraft and satellites. It is a common window material for X-ray equipment and components of particle physics experiments. It is also used in thermal management applications. **CAS** 7787-56-6.

Betamethasone-17,21-dipropionate

B-042	C ₂₈ H ₃₇ FO ₇	504.59	CS
-------	---	--------	----

Betamethasone dipropionate is a glucocorticoid steroid with anti-inflammatory and immunosuppressive abilities. It is applied as a topical cream, ointment, lotion, aerosol sprays or gel to treat itching and other minor skin conditions such as eczema. **CAS** 5593-20-4.

Betamethasone-17-valerate

B-031	C ₂₇ H ₃₇ FO ₆	476.26	CS
-------	---	--------	----

Topical and systemic corticosteroid of group C type with a C-16 methyl substitution. **CAS** 2152-44-5

BHT

D-006	C ₁₅ H ₂₄ O	220.36	B, C, PG, LU, AC
-------	-----------------------------------	--------	------------------

Used as an antioxidant in foods (beverages, gum, ice cream, fruits, cereals), cosmetics, topical medications, animal feeds, petroleum products, jet fuels, rubber, plastics, paints, glues. Also known as Butyl hydroxy toluene and 2,6-Di-tert-butyl-4-cresol. **Cross: Lidocaine. UCU. CAS** 128-37-0

Bioban CS 1135

D-015			O
-------	--	--	---

Trade name of a product that consists of two components: 4,4-Dimethyl-oxazolidine and 3,4,4-Trimethyl-oxazolidine. See the respective component for further information. **CAS** 75673-43-7

Art. No.	Formula	FW	Series
Bioban P 1487			
E-014			O

Trade name of a product that consists of two components: 4-(2-Nitrobutyl) morpholine and 4,4-(2-Ethyl-2-nitro-trimethylene) dimorpholine. See the respective name for further information.

Birch tar

Birch tar derived from the dry distillation of the bark of the birch tree. It is compounded of guaiacol, phenols, cresol, xylenol and creosol. Used as a component in pharmaceutical preparations. Available as part of Mx-14.

BIS-ETHYLHEXYLOXYPHENOL METHOXYPHENOL TRIAZINE

B-037	C ₃₈ H ₄₉ N ₃ O ₅	627.81	SU, EP, EPE
-------	---	--------	-------------

Used in sunscreens to absorb UV rays and is highly photostable. It is a broad spectrum UV absorber, absorbing UVB as well as UVA rays. Also known as Tinosorb S and Bis-Ethylhexyloxyphenol Methoxyphenyl Triazine. **CAS** 187393-00-6

Bisphenol A dimethacrylate

M-007	C ₂₃ H ₂₄ O ₄	364.44	DS, MA
-------	--	--------	--------

Methacrylic monomer based on bisphenol A. Used in dental restorative composite and adhesive materials. Also known as 2,2-bis(4-Methacryloxy)phenylpropane and BIS-MA. **CAS** 3253-39-2.

Bisphenol A glycerolate dimethacrylate

H-013	C ₂₉ H ₃₆ O ₈	512.61	DS, MA, DMP, DMS
-------	--	--------	------------------

Common methacrylic monomer in dental composite restorative materials and dental sealants. This monomer is also extensively used in industrial applications. Also known as 2,2-bis(4-(2-Hydroxy-3-methacryloxypropoxy)phenyl)propane and BIS-GMA. **CAS** 1565-94-2.

Art. No.	Formula	FW	Series
----------	---------	----	--------

Bisphenol A

B-013	$C_{15}H_{16}O_2$	228.29	PG
-------	-------------------	--------	----

Comes from raw material in the production of epoxy and acrylic resins. Is a component in semisynthetic waxes. Also known as 4,4-Isopropylidene diphenol. **Cross:** diethylstilbestrol, hydroquinonemonobenzyl ether. **CAS** 80-05-7.

Bithionol

B-014	$C_{12}H_6Cl_4O_2S$	356.07	6
-------	---------------------	--------	---

Used as antibacterial agent in soaps, cosmetics, agricultural fungicides, veterinaryantiseptic and antihelminthic products, industrial cleansers, etc. 2,2-Thiobis (4,6-dichlorophenol). **PA. PL. CAS** 97-18-7

BORNANEDIONE

C-026	$C_{10}H_{14}O_2$	166.22	DS
-------	-------------------	--------	----

An initiator for visible light cured dental acrylic composite materials. Also known as Camphoroquinone and Camphorquinone. **CAS** 10373-78-1

2-BROMO-2-NITROPROPANE-1,3-DIOL

B-015	$C_3H_6BrNO_4$	199.99	ICB, C, H, O, NA, AC, NAE, NAC, ECB
-------	----------------	--------	-------------------------------------

Used a preservative in cooling fluids, hand & face creams, shampoos, hair dressings, mascaras, cleansing lotions, milk sampling, paints, textiles, humidifiers, pharmaceutical products, washing detergents (Bronopol). **CAS** 52-51-7.

Budesonide

B-033	$C_{25}H_{34}O_6$	430.55	NAE, NAC, S, ICB, CS, LA, AC IS, LU, NA, ECB
-------	-------------------	--------	--

A nonhalogenated corticosteroid for use in topical preparations and for the treatment of rhinitis and asthma. Belongs to the group B (triamcinolone acetonide) type of corticosteroids. Good marker of corticosteroid allergy. Also available as part of Mx-23. **Cross:** Flucinolone acetonide, Hydrocortisone, Hydrocortisone-17-butyrate, Prednisolone Acetate, Tixocortol-21-Pivalate, Triamcinolone acetonide. **CAS** 51333-22-3

120

Art. No.	Formula	FW	Series
----------	---------	----	--------

Bufexamac

B-043	$C_{12}H_{17}NO_3$	223.27	ME
-------	--------------------	--------	----

Drug used as an anti-inflammatory agent on the skin, as well as rectally. Ointments and lotions containing bufexamac are used for the treatment of subacute and chronic eczema of the skin, including atopic eczema, as well as sunburn and other minor burns, and itching. Suppositories containing bufexamac in combination with local anaesthetics are used against haemorrhoids. **CAS** 2438-72-4.

1,4-Butanediol diacrylate

B-016	$C_{10}H_{14}O_4$	198.24	MP
-------	-------------------	--------	----

A cross-linking monomer for use in inks, adhesives, textile product modifiers, photo resists, etc. Also known as BUDA. **CAS** 1070-70-8.

1,4-Butanediol diglycidyl ether

Deleted 2021	$C_{10}H_{18}O_4$	202.25	
--------------	-------------------	--------	--

A difunctional glycidylether of butyl alcohol; containing 2 epoxide groups (three-membered ring cyclic ethers that are also known as oxiranes or alkylene oxides). It is used as a general purpose diluent to reduce the viscosity of epoxy resins. Also used as rubber adhesive. Also known as Araldite RD-2; 1,4-Bis(2,3-epoxypropoxy) butane. **CAS** 2425-79-8.

1,4-Butanediol dimethacrylate

B-017	$C_{12}H_{18}O_4$	226.28	MA, DS, DMP, DMS
-------	-------------------	--------	------------------

A cross-linking methacrylic monomer for use in dental composite materials, sealants, prostheses, etc. Also known as BUDMA. **CAS** 2082-81-7.

Butyl acrylate

B-018	$C_7H_{12}O_2$	128.17	MN
-------	----------------	--------	----

A cross-linking acrylic monomer for use in textile and leather finishes, paint formulations, etc. Also known as BA. **CAS** 141-32-2.

Art. No.	Formula	FW	Series
4-tert-Butylbenzoic acid			
B-019	C ₁₁ H ₁₄ O ₂	178.24	O

Used as corrosion inhibitor in cooling fluids. **CAS** 98-73-7.

4-tert-Butylcatechol

B-030	C ₁₀ H ₁₄ O ₂	166.22	PG
-------	--	--------	----

An antioxidant found in polyester resins and as polymerization inhibitor in PVC. Also described as hapten in photocopying paper and as antioxidant in oil. Also known as PTBC. **May cause depigmentation.** **CAS** 98-29-3.

t-BUTYL HYDROQUINONE

B-028	C ₁₀ H ₁₄ O ₂	166.22	C
-------	--	--------	---

Used as an antioxidant in cosmetic products like lipsticks. **CAS** 1948-33-0.

BUTYL METHACRYLATE

B-021	C ₈ H ₁₄ O ₂	142.20	MA, MN, MP
-------	---	--------	------------

A cross-linking methacrylic monomer for use in dental composite materials, artificial nails, etc. Also known as BMA. **CAS** 97-88-1.

BUTYL METHOXYDIBENZOYLMETHANE

B-029	C ₂₀ H ₂₂ O ₃	310.20	SU, EP, EPE
-------	--	--------	-------------

A UV-A-ray adsorbing agent in sunscreen cosmetics of the type creams, lotions, lipsticks, sun oils, etc. (Parsol 1789). Also known as tert-Butyl-4'-methoxydibenzoylmethane. **CAS** 70356-09-1.

2-tert-Butyl-4-methoxyphenol

B-022	C ₁₁ H ₁₆ O ₂	180.25	ICB, B, C, PG, NAC
-------	--	--------	--------------------

Used as an antioxidant in foods (beverages, gum, ice cream, fruits, cereals), cosmetics, topical medications, animal feeds, petroleum products, jet fuels, rubber, plastics, paints, glues. Also known as BHA. **May cause depigmentation. May cause airborne contact dermatitis. UCU. CAS** 121-00-6.

Art. No.	Formula	FW	Series
BUTYL PARABEN			
Deleted 2021	C ₁₁ H ₁₄ O ₃	194.23	

Used as preservative in foods (salad dressings, mayonnaise, spiced sauces, mustard, frozen dairy products, baked products), cosmetics and pharmaceutical preparations. Also known as Butyl-4-hydroxybenzoate. Also available as part of Mx-03A, Mx-03C. **CAS** 94-26-8.

4-tert-Butylphenol

B-023	C ₁₀ H ₁₄ O	150.21	PG
-------	-----------------------------------	--------	----

An intermediate in the production of lacquer and varnish resins. Antioxidant in plastics, adhesives, etc. **May cause depigmentation.** **CAS** 98-54-4.

4-tert-Butylphenolformaldehyde resin

B-024			ICB, PG, S, SH, IS NA, NAE, NAC, ECB, LA, AC
-------	--	--	--

Resin used in adhesives for shoes and watch straps. Also found in do-it-yourself glues, plywood, insulation, automobiles, motor oils, inks, papers, film developers, disinfectants, deodorants. Also known as PTBP. **May cause depigmentation.**

BUTYLPHENYL METHYLPROPIONAL

B-040	C ₁₄ H ₂₀ O	204.30	F
-------	-----------------------------------	--------	---

Common fragrance found in soaps, detergents, beauty care products and household products. It is also used as an intermediate for the synthesis of agrochemicals. Also known as Lilial and Lilialdehyde. **CAS** 80-54-6.

Art. No.	Formula	FW	Series
----------	---------	----	--------

C

Cadmium chloride

C-001	CdCl ₂	183.32	MET
-------	-------------------	--------	-----

This hapten is a marker for contact allergy to **cadmium**. Used in photography, the production of cadmium yellow. Works as fungicide and anticorrosive agent. Also used in pigments for glass, tattoos, and paints. **CAS** 10108-64-2.

CALCIUM TITANATE

C-049	CaO ₃ Ti	135.96	MET
-------	---------------------	--------	-----

This hapten is a marker for contact allergy to **titanium**. Used in a method of manufacturing a ceramic capacitor suitable for high energy density and high temperature application. Uses are for example, as an antenna material, a capacitor material, a layered circuit substrate material, a connector material, and the like which are required to be dielectric. **CAS** 12049-50-2.

Camphoroquinone

Change of name as of January 2015; please refer to BORNANEDIONE (Art. No. C-026).

CANANGA ODORATA OIL

Change of name as of January 2016; please refer to Ylang ylang oil (Art. No. Y-001).

Cananga oil

C-002			F
-------	--	--	---

This substance is used as a fragrance in household products and cosmetic products like washing detergents, skin lotion and perfumes. The oil is steam distilled from the flowers of *Cananga odorata macrophylla*. The oil has a warm, sweet floral scent with a hint of tree and leather. Contains among other substances beta-Caryophyllene, Geranyl acetate, Benzyl benzoate, Linalool, Methyl benzoate, Benzyl salicylate, Farnesol, Geraniol, Eugenol and Citral.

Art. No.	Formula	FW	Series
----------	---------	----	--------

Cross: benzyl salicylate. May cause pigmentation of the face.
CAS 68606-83-7.

Captan

C-025	C ₉ H ₈ Cl ₃ NO ₂ S	300.57	H
-------	---	--------	---

Used as a fungicide on vegetables, fruits, and different types of plants. Used as bacteriostat in soaps, shampoos, hair tonics, animal flea removers and tick sprays. Also known as N-trichloromethylthio-4-cyclohexene-1,2-dicarboximide, Vancide, Dangard and Merpan. **May cause airborne contact dermatitis.** **CAS** 133-06-2

Captopril

C-045	C ₉ H ₁₅ NO ₃ S	217.28	CAD
-------	--	--------	-----

Captopril is an angiotensin-converting enzyme inhibitor (ACE inhibitor) used for the treatment of hypertension and some types of congestive heart failure. Captopril's main uses are based on its vasodilatation and inhibition of some renal function activities. **CAS** 62571-86-2.

Carbamazepine

C-044	C ₁₅ H ₁₂ N ₂ O	236.27	CAD
-------	--	--------	-----

Carbamazepine is an anticonvulsant and mood stabilizing drug, used primarily in the treatment of epilepsy and bipolar disorder. It is also used to treat ADD, ADHD, schizophrenia and trigeminal neuralgia. Also known as CBZ and 5H-dibenz[b,f]azepine-5-carboxamide. **CAS** 298-46-4.

CARVONE

C-035	C ₁₀ H ₁₄ O	150.22	DS, DMP
-------	-----------------------------------	--------	---------

Found in several essential oils and is used for flavouring liqueurs, soaps, dental materials and perfumes. Also known as 2-Cyclohexen-1-one, 2-methyl-5-(1-methylethenyl)-, (5R)-(9Cl) and (R)- Carvone. **CAS** 6485-40-1

Art. No.	Formula	FW	Series
Cefalexin			
C-048	$C_{16}H_{17}N_3O_4S$	347.39	CAD

First-generation cephalosporin antibiotic and it is an orally-administered agent with a similar antimicrobial spectrum to the intravenous agents cefalotin and cefazolin. It is used to treat urinary tract infections, respiratory tract infections (including sinusitis, otitis media, pharyngitis, tonsillitis and pneumonia), skin and soft tissue infections. Although it is not generally considered first-line therapy for any indication, it is a useful alternative to penicillins in patients with penicillin hypersensitivity. There is, however, cross-reactivity in 10% of patients with hypersensitivity to penicillins and carbapenems. **CAS** 23325-78-2.

Cefixime trihydrate

C-054	$C_{16}H_{15}N_5O_7S_2$	507.50	CAD
-------	-------------------------	--------	-----

This substance is a second-generation cephalosporin antibiotic. It is a broad spectrum cephalosporin antibiotic and is commonly used to treat bacterial infections of the ear, urinary tract and upper respiratory tract. **CAS** 125110-14-7.

Cefotaxim sodium salt

C-040	$C_{16}H_{16}N_5NaO_7S_2$	477.04	CAD
-------	---------------------------	--------	-----

A cephalosporin that belongs to a group of broad-spectrum antibiotic derived from species of fungi of the genus Cephalosporium and are related to the penicillins in both structure and mode of action but relatively penicillinase-resistant antibiotics. Third-generation cephalosporins are more active against gram-negative organisms but less active against gram-positive organisms than second-generation agents; examples are cefoperazone, cefotaxime, ceftriaxone, ceftazidime, ceftizoxime, and moxalactam. **CAS** 64485-93-4

Cefpodoxime proxetil

C-055	$C_{21}H_{27}N_5O_9S_2$	557.60	CAD
-------	-------------------------	--------	-----

This substance is an oral, third-generation cephalosporin antibiotic. It is active against most Gram-positive and Gram-negative organisms. It is commonly used to treat acute otitis media, pharyngitis, sinusitis, and gonorrhoea. Veterinary uses is also found. **CAS** 87239-81-4.

Art. No.	Formula	FW	Series
Cefradine			
C-047	$C_{16}H_{19}N_3O_4S$	349.40	CAD

Cefradine or cephradine is a first generation cephalosporin antibiotic. Effective against a wide range of gram-positive and a limited range of gram-negative bacteria.

Cefuroxime sodium

C-053	$C_{16}H_{15}N_4NaO_8S$	446.37	CAD
-------	-------------------------	--------	-----

This substance is an enteral second-generation cephalosporin antibiotic. It is used to treat pneumonia and other lower respiratory tract (lung) infections; meningitis, gonorrhoea, and skin, blood, bone, joint and urinary tract infections. Injections of the medicine may also be used before, during, and sometimes for a brief period after surgery. **CAS** 56238-63-2.

CETYL ALCOHOL

C-003	$C_{16}H_{34}O$	242.45	C
-------	-----------------	--------	---

Used as emulsifier and emollient in cosmetics and pharmaceutical preparations. **UCU. CAS** 36653-82-4.

CETEARYL ALCOHOL

C-033			LU, AC
-------	--	--	--------

A combination of cetyl (C16) and stearyl (C18) alcohols 50/50 used as emulsifier and emollient in cosmetic lotions, creams, ointments and pharmaceutical preparations. Also known as Lanette O. **UCU. CAS** 67762-27-0

CETEARYL GLUCOSIDE

C-056			C
-------	--	--	---

Used as an emulsifier in peg-free lotions and creams. Suitable for low viscosity lotions (sprays), lotions, creams and foams. **CAS** 246159-33-1

Art. No.	Formula	FW	Series
CETRIMONIUM BROMIDE			
C-050	$C_{19}H_{42}BrN$	364.45	H

One of the components of the topical antiseptic cetrimide. The cetrimonium (or hexadecyltrimethylammonium) cation is an effective antiseptic agent against bacteria and fungi. It is a cationic surfactant. Its uses include providing a buffer solution for the extraction of DNA. It is also widely used in hair conditioning products. Also known as Cetrimide. **CAS** 57-09-0.

Chamomilla recutita extract

C-051			PL
-------	--	--	----

Chamomilla Recutita; Matricaria recutita or German chamomile, also spelled camomile, is an annual plant of the composite family Asteraceae. Chamomilla chamomilla, Chamomilla recutita (accepted name according to the Flora Europaea), Matricaria chamomilla, and Matricaria suaveolens. It usually grows near populated areas all over Europe and temperate Asia. It is widely introduced in temperate North America and Australia. As the seeds need open soil to survive, it often grows near roads, around landfills and in cultivated fields as a weed. The raw material for this product is made from an ethanol extraction of the plant/flowers of Chamomilla Recutita. Also available as part of Mx-29A and Mx-29B.

Chloramphenicol

C-032	$C_{11}H_{12}Cl_2N_2O_5$	323.14	ME, LU
-------	--------------------------	--------	--------

An antibiotic substance produced by Streptomyces venezuelae. Present in eye drops, ointments and for systemic use. Used as bactericide against the rot of potatoes and other root vegetables. **Cross: Azidamfenicol. ICU. CAS** 56-75-7.

CHLORHEXIDINE DIACETATE

C-004	$C_{26}H_{38}Cl_2N_{10}O_4$	625.56	
-------	-----------------------------	--------	--

An antimicrobial agent used in cosmetic and disinfection solutions, eye drops, uterine antiseptics, toothpaste, mouthwash, hand and wound cleansers. **PA. ICU. CAS** 56-95-1

Art. No.	Formula	FW	Series
CHLORHEXIDINE DIGLUCONATE			
C-005	$C_{34}H_{54}Cl_2N_{10}O_{14}$	897.88	C, LU, AC

An antimicrobial agent used in cosmetic and pharmaceutical creams, surgical soaps, anticaries solutions, toothpaste, mouthwash, hand and wound cleansers etc. **PA. ICU. CAS** 18472-51-0.

CHLOROACETAMIDE

C-006	C_2H_4ClNO	93.51	C, H, O, LU
-------	--------------	-------	-------------

A preservative in cosmetic and pharmaceutical creams, shampoos, bath lotions, etc. Also as preservative in glues and cooling fluids. Also known as 2-Chloroacetamide. **May cause airborne contact dermatitis. CAS** 79-07-2.

p-CHLORO-m-CRESOL

C-008	C_7H_7ClO	142.59	C, H, O, LU, AC
-------	-------------	--------	-----------------

A fungicide found in creams, topical antiseptics, pharmaceutical products, protein shampoos, baby cosmetics, and cooling fluids. (PCMC). Also known as 4-Chloro-3-cresol. **Cross: 4-chloro-3-xyleneol. ICU. CAS** 59-50-7.

CHLOROXYLENOL (PCMX)

C-010	C_8H_9ClO	156.61	C, H, O, NAE, NAC, AC
-------	-------------	--------	-----------------------

A preservative found in cooling fluids, creams, topical and urinary antiseptics. Can also be found in pharmaceutical products, hair conditioners, toilet and deodorants, soaps, electrocardiogram paste, etc. Also known as 4-Chloro-3,5-xyleneol. **Cross: 4-chloro-3-cresol. CAS** 88-04-0.

Chlorpromazine hydrochloride

Deleted 2021	$C_{17}H_{20}Cl_2N_2S$	355.35	
--------------	------------------------	--------	--

An antiemetic and antipsychotic agent found in pills, injections, and suppositories. **Cross: diethazine HCl, promethazine HCl, thiazinamium, ethopropazine HCl. May cause airborne contact dermatitis. PA, PT (systemic). CAS** 69-09-0.

Art. No.	Formula	FW	Series
----------	---------	----	--------

Chlorquinaldol

Deleted 2021	C ₁₀ H ₇ Cl ₂ NO	228.08	
--------------	---	--------	--

A fungicide and antibacterial agent found in topical pharmaceutical preparations. Also known as 5,7-dichloro-2-methyl-8-quinolinol and Sterosan. Also available as part of Mx-02. **Cross; clioquinol. CAS 72-80-0.**

Chrysanthemum Cinerariaefolium extract

C-031			PL
-------	--	--	----

A compositae plant that grows on rocky ground in Europe, Australia, Japan and N.America. The raw material for this product is made from an ethanol extraction of the plant/flowers of Chrysanthemum Cinerariaefolium. Pyrethrum is the main source of the pyrethrum insecticide. Principal hapten is pyrethrosin. **ICU.**

CINNAMAL

C-014	C ₉ H ₈ O	132.16	ICB, B, F, NA NAE, NAC, AC
-------	---------------------------------	--------	-------------------------------

A common ingredient in perfumes for household products like deodorizers, detergents, and soap. Flavor in toothpaste, sweets, ice cream, soft drinks, chewing gums, and cakes. Also present in Tolu balsam absolute and Peru balsam, hyacinth plant, spices, cinnamon, Ceylon and cassia oil. Also known as Cinnamic aldehyde. Also available as part of Mx-07. **Cross: CINNAMYL ALCOHOL, cinnamon oil. May cause depigmentation. PA. NICU. CAS 104-55-2.**

CINNAMYL ALCOHOL

C-013	C ₉ H ₁₀ O	134.18	B, F
-------	----------------------------------	--------	------

A component found in perfumed cosmetic products and deodorants. Also known as Cinnamic alcohol. Also available as part of Mx-07. **Cross: Peru balsam, Propolis. May cause pigmentation of the face. CAS 104-54-1.**

Art. No.	Formula	FW	Series
----------	---------	----	--------

Ciprofloxacin hydrochloride

C-043	C ₁₇ H ₂₁ ClFN ₃ O ₄	385.82	CAD
-------	--	--------	-----

A quinolone, which is an antibiotic drug used mainly to treat the respiratory infections (pneumoniae, pseudomonas, influenzae), urinary tract infections, the gastrointestinal surgery, typhoid fever, gonorrhoea (enterotoxigenic strains of Escherichia coli), and septicaemia. Ciprofloxacin act by inhibiting the bacterial enzymes DNA gyrase. Other quinolones include cinoxacin; levofloxacin; nalidixic acid; norfloxacin; ofloxacin. **CAS 86393-32-0**

CITRAL

C-036	C ₁₀ H ₁₆ O	152.24	F
-------	-----------------------------------	--------	---

Fragrance for use in various perfumes. Examples of usage: in citrus notes and floral fragrance blends and as an intermediate to form other compounds. Also known as Geranial; Geranialdehyde; 3,7-Dimethyl-2,6-octadienal. Also available as part of Mx-25. **CAS 5392-40-5.**

CITRONELLOL

C-037	C ₁₀ H ₂₀ O	156.27	F
-------	-----------------------------------	--------	---

A fragrance used in various perfumed products. Citronella oil is a yellowish essential oil distilled from the leaves of either of two grasses, Cymbopogon nardus or C. winterianus. This aromatic oil is inexpensive, and widely used in cheap perfumes and as a fragrance in soaps. It is also best known as an insect repellent. Citronellol, derived from citronella oil, is a chief constituent of geranium oil, another is GERANIOL. Both are used in the production of perfumes. (smells sweet, rose, lilac, geranium). Also known as 3,7-dimethyl-6-Octen-1-ol. Also available as part of Mx-25. **CAS 106-22-9.**

Clarithromycin

C-041	C ₃₈ H ₆₉ NO ₁₃	747.96	CAD
-------	--	--------	-----

Clarithromycin, belonging to the macrolide group, has a close structural and biological similarity with erythromycin. It is effective against a broad spectrum of gram-positive and gram-negative bacteria. It is used to treat respiratory tract infections and soft tissue infections. It is used to treat duodenal ulcer associated with Helicobacter pylori infections in combination with omeprazole. Also known as 6-O-methylerythromycin. **CAS 81103-11-9**

Art. No.	Formula	FW	Series
----------	---------	----	--------

Clindamycin phosphate

C-046	$C_{18}H_{34}ClN_2O_8PS$	504.96	CAD
-------	--------------------------	--------	-----

Clindamycin (phosphate) is a lincosamide antibiotic used in the treatment of infections caused by susceptible microorganisms. Such infections might include infections of the respiratory tract, septicemia and peritonitis. In patients with hypersensitivity to penicillins, clindamycin (phosphate) may be used to treat infections caused by susceptible aerobic bacteria as well. It is also used to treat bone infections caused by *Staphylococcus aureus*. Topical application of clindamycin phosphate can be used to treat moderate to severe acne. **CAS** 24729-96-2.

Clioquinol

C-015	C_9H_5ClINO	305.50	C, LA
-------	---------------	--------	-------

An antiinfective and antiamebic agent used in topical pharmaceutical preparations. Also known as 5-chloro-7-iodo-8-quinolinol, Chinoform and Vioform. Also available as part of Mx-02. **May cause brown discoloration of the nails and erythema multiforme like eruptions.** **UCU.** **CAS** 130-26-7.

Clobetasol-17-propionate

C-028	$C_{25}H_{32}ClFO_5$	466.73	ICB, CS, NAE, NAC, AC
-------	----------------------	--------	-----------------------

A topical corticosteroid belonging to the group D (Hydrocortisone-17-butyrate) type of steroids. **Cross: Alclometasone dipropionate, Betamethasone-17 Valerate, Clobetasol-17-propionate, Desoximetasone, Dexamethasone-21-Phosphate.** **UCU.** **CAS** 25122-46-7.

Coal tar

C-016			
-------	--	--	--

A by-product in the distillation of coal. Topical antieczematogenic agent. **PA. PT. PL.** **May cause postinflammatory hyperpigmentation.** **CAS** 8007-45-2.

Art. No.	Formula	FW	Series
----------	---------	----	--------

Cobalt(II)chloride hexahydrate

C-017	$CoCl_2 \cdot 6H_2O$	237.93	S, ICB, DS, H, LA, DMP, ECB, NA, NAE, NAC, AC
-------	----------------------	--------	---

This hapten is a marker for contact allergy to **cobalt**. A component used in coloring of glass and porcelain. Works as a siccative in paints. Used in various alloys (dental, etc.). **May produce erythema multiforme like eruptions. May cause airborne contact dermatitis.** **NICU.** **CAS** 7791-13-1.

COCAMIDE DEA

C-019			ICB, O, NAE, NAC, AC
-------	--	--	----------------------

Mixture of ethanolamides of coconut acid. Found in bath, shower and body cosmetics and in cooling fluids. Also known as Coconut diethanolamide. **CAS** 68603-42-9.

COCAMIDOPROPYL BETAINE

C-018	C_4H_8NO		ICB, C, H, NA, AC, NAE, NAC, LA
-------	------------	--	---------------------------------

A surfactant found in liquid soaps, shampoos, hair colorants, shower & bath formulations. Also known as Tegobetaine. **Cross: cocobetaine.** **CAS** 61789-40-0

COLOPHONIUM

C-020			S, ICB, DS, SH, IS, DMP, ECB, NA, NAE, NAC, LA, AC
-------	--	--	--

A yellow resin used in the production of varnishes, printing inks, paper, soldering fluxes, cutting fluids, glue tackifiers, adhesives, surface coatings, polish, waxes, cosmetics (mascara, rouge, eye shadow), topical medicaments, violin bow rosin, athletic grip aid, pine oil cleansers. Component in dental impression materials and periodontal packings. (rosin). Also known as Colophony **Cross: Peru balsam, dihydroabietyl alcohol, wood tars.** **May cause airborne contact dermatitis.** **ICU.** **CAS** 8050-09-7.

Art. No.	Formula	FW	Series
Copper(I)oxide			
C-021	Cu ₂ O	143.08	MET

This hapten is a marker for contact allergy to **copper**. Used as fungicide and as pigment to make glass red. Found in antifouling paints Also known as Cuprous oxide. **CAS** 1317-39-1

Art. No.	Formula	FW	Series
Copper(II)sulfate pentahydrate			
C-022	CuSO ₄ · 5H ₂ O	249.68	DS, MET

This hapten is a marker for contact allergy to **copper**. Works as a fungicide. Used as pigment in paints and reagent toner in photography. Copper metal is used in, e.g., dental alloys. Also known as Cupric sulfate. **ICU. CAS** 7758-99-8.

Art. No.	Series
Costunolide	
Mx-18	S, ICB, IS, PL

Sesquiterpene lactone isolated from the Compositae plant Saussurea lappa. The oil which is extracted from Saussurea lappa is used in perfumery and in the Orient for all kinds of diseases. Costunolide is present in the plant together with dehydrocostus lactone. May cause airborne contact dermatitis. Only available in mix (Mx-18). **CAS** 553-21-9.

Art. No.	Formula	FW	Series
Cotrimoxazole			
C-042	$\begin{matrix} C_{14}H_{18}N_4O_3 \\ C_{10}H_{11}N_3O_3S \end{matrix}$	543.19	CAD

Cotrimoxazole is an antibiotic combination of trimethoprim and sulfamethoxazole, in the ratio of 1 to 5, used in the treatment of a variety of bacterial infections. The name cotrimoxazole is the British Approved Name, and has been marketed worldwide under many trade names. Other sources list this antibiotic as bacteriostatic. **CAS** 8064-90-2

Art. No.	Formula	FW	Series
COUMARIN			
C-038	C ₉ H ₆ O ₂	146.15	F

A fragrance used in various perfumed products. Coumarin (anhydride of o-coumaric acid) is white, crystalline lactone, obtainable naturally

Art. No.	Formula	FW	Series
Cyclohexanone resin			
Deleted 2019			

from several plants, such as tonka bean, lavender, sweet clover grass, strawberries, and cinnamon, or produced synthetically from an amino acid, phenylalanine. Coumarin has the characteristic odour like that of vanilla beans. It is used for the preparation of perfumes, soaps, flavourings. Also known as 2H-1-Benzopyran-2-one. Also available as part of Mx-25. **CAS** 91-64-5.

Art. No.	Formula	FW	Series
Cyclohexanone resin			
Deleted 2019			

Formed by the condensation of cyclohexanone. Used to enhance the adhesive properties of products like alkyd-, nitro-, and chlorocacoutchouc lacquers. Most often used in floor paints. **May cause airborne contact dermatitis.**

Art. No.	Formula	FW	Series
N-Cyclohexyl-2-benzothiazolylsulfenamide			
C-023	C ₁₃ H ₁₆ N ₂ S ₂	264.41	R

An accelerator in natural and styrene-butadienethiazyl sulfenamide rubber Also known as CBS. Also available as part of Mx-05A, Mx-05B. **CAS** 95-33-0

Art. No.	Formula	FW	Series
N-Cyclohexyl-N-phenyl-4-phenylenediamine			
C-024	C ₁₈ H ₂₂ N ₂	266.42	R

Used as antidegradant in natural rubber, styrene-butadiene and chloroprene rubber. Also known as CPPD. Also available as part of Mx-04. **CAS** 101-87-1.

Art. No.	Formula	FW	Series
N-(Cyclohexylthio) phthalimide			
C-034	C ₁₄ H ₁₅ NO ₂ S	261.34	R

A vulcanization retarder widely used in various rubber products. Brand name include Santogard PVI. **CAS** 17796-82-6.

Art. No.	Formula	FW	Series
CYSTEAMINE HCL			
C-052	C ₂ H ₇ NS · HCl	113.61	H

This substance is used in hair dye products. **CAS** 156-57-0

Art. No.	Formula	FW	Series
D			
DECYL GLUCOSIDE			
D-065	$C_{16}H_{32}O_6$	320.43	ICB, AC, C, EP, EPE, ECB, NA, NAE, NAC

Decyl glucoside is a mild non-ionic surfactant used in cosmetic formulations including baby shampoo and in products for individuals with a sensitive skin. Many natural personal care companies use this cleanser because it is plant-derived, biodegradable, and gentle for all hair types. **Cross: Variety of Alkyl polyglucosides, for example Octyldodecyl xyloside, Cetearyl Glucoside and Lauryl Glucoside. CAS 54549-25-6**

Dehydrocostus lactone

Mx-18 S, ICB, IS, PL

Sesquiterpene lactone isolated from the Compositae plant Saussurea lappa. The oil which is extracted from Saussurea lappa is used in perfumery and in the Orient for all kinds of diseases. Dehydrocostus lactone is present in the plant together with costunolide. **May cause airborne contact dermatitis.** (Only available in mix). **CAS 477-43-0.**

Dermatophagoides Pteronyssinus/Pharinae

Mx-21 SA

House dust mite aerohapten causing atopic dermatitis. . Mix of 2 species for "Atopic" patch testing. **May cause airborne contact dermatitis.**

Desoximetasone

D-057 $C_{22}H_{29}FO_4$ 376.46 ICB, CS, NAE, NAC

Like other topical corticosteroids, desoximetasone has anti-inflammatory, antipruritic, and vasoconstrictive properties. Once absorbed through the skin, topical corticosteroids are handled through pharmacokinetic pathways similar to systemically administered corticosteroids. **Cross: Alclometasone dipropionate,**

Art. No.	Formula	FW	Series
Betamethasone-17 Valerate, Clobetasol-17-propionate, Dexamethasone-21-Phosphate. CAS 382-67-2			

Dexamethasone-21-phosphate disodium salt

D-046 $C_{22}H_{28}FNa_2O_8P$ 516.40 CS

Corticosteroid of the group C (betamethasone) type. Used in eye and ear preparations and in systemic preparations. **CAS 2392-39-4.**

Dexketoprofen

Deleted 2021 $C_{16}H_{15}O_3$ 254.28

ANASID that is used to treat moderate pain, including dysmenorrhea. It acts by inhibiting the body's production of prostaglandin. Also known as (S)-(+)-Ketoprofen, (S)-(+)-3-Benzoyl- α -methylbenzeneacetic acid and (S)-2-(3-Benzoylphenyl)propionic acid. **CAS 22161-81-5.**

Diallyl disulfide

D-048 $C_6H_{10}S_2$ 146.28 PL

One of the three principal low molecular weight haptens of garlic. Allylpropyl disulfide and allicin are the other haptens in garlic. **CAS 2179-57-9.**

4,4'-Diaminodiphenylmethane (MDA)

D-001 $C_{13}H_{14}N_2$ 198.27 E, I, R

A curing agent for epoxy resins and urethane elastomers. Used as corrosion inhibitor and rubber additive (accelerator, antidegradant, retarder) in tires and heavy rubber products. Also used in adhesives and glues, laminates, paints and inks, PVC products, handbags, eyeglass frames, plastic jewelry, electric encapsulators, surface coatings, spandex clothing, hairnets, eyelash curlers, earphones, balls, shoe soles, face masks. **Crossreacts with other p-amino substituted benzene compounds such as benzocaine and PABA. May produce erythema multiforme like eruptions. CAS 101-77-9.**

Art. No.	Formula	FW	Series
DIAZOLIDINYL UREA			
D-044	$C_8H_{14}N_4O_7$	278.22	ICB, C, IS, H, LU, ECB, NA, NAE, NAC, LA, AC

A preservative used in cosmetic creams, lotions, shampoos, hair gels, etc. (Germall II). Also known as 2,5-Diazolidinylurea. **Cross: IMIDAZOLIDINYL UREA, FORMALDEHYDE. CAS 78491-02-8.**

Dibenzothiazyl disulfide (MBTS)

D-003	$C_{14}H_8N_2S_4$	332.50	R
-------	-------------------	--------	---

An accelerator for natural rubber, nitrile-butadiene, butyl and styrene-butadiene rubber. Also used as retarder for chloroprene rubber. Also available as part of Mx-05A, Mx-05B. **CAS 120-78-5.**

Dibucaine hydrochloride

D-005	$C_{20}H_{30}ClN_3O_2$	379.92	ICB, NAE, NAC
-------	------------------------	--------	---------------

Used as local anesthetic agent. Also known as Cinchocaine HCl, Nupercaine HCl, Percaine and Cincaine. Also available as part of Mx-13 and Mx-19. **Cross: Lidocaine. PA. CAS 61-12-1.**

Dibutyl phthalate

D-007	$C_{16}H_{22}O_4$	278.35	PG
-------	-------------------	--------	----

Used as emollient in aerosol antiperspirants, insect repeller and as plasticizer in various plastic materials. **CAS 84-74-2.**

N,N'-Dibutylthiourea

D-038	$(C_4H_9NH)_2CS$	188.33	SH, R
-------	------------------	--------	-------

An accelerator for mercaptan-modified chloroprene rubber. Used as activator for ethylene-propylene-diene terpolymers and natural rubber. An antidegradant for natural rubber-latex and thermoplastic styrene-butadiene rubber. Also available as part of Mx-24 and Mx-27. **CAS 109-46-6.**

Art. No.	Formula	FW	Series
DICHLOROPHENE			
D-008	$C_{13}H_{10}Cl_2O_2$	269.13	O

Used as bactericide, fungicide, and algicide in soaps, cosmetics, shampoos, dentifrices, toothpaste, mouthwashes, deodorants, foot powders, papers, adhesives and bandages, and cooling fluids. **Cross: hexachlorophene. CAS 97-23-4.**

Diclofenac sodium salt

D-061	$C_{14}H_{10}Cl_2NNaO_2$	318.13	CAD, EPE
-------	--------------------------	--------	----------

Diclofenac (marketed as Voltaren, Voltarol, Diclon, Dicloflex Difen, Difene, Cataflam, Pennsaid, Rhumalgan, Modifenac, Abitren, Arthrotec and Zolterol, with various drug dose combinations) is a NSAID taken to reduce inflammation and an analgesic reducing pain in conditions such as in arthritis or acute injury. It can also be used to reduce dysmenorrhea. The name is derived from its chemical name: 2-(2,6-dichloranilino) phenylacetic acid. **CAS 15307-79-6.**

Dicloxacillin sodium salt hydrate

D-058	$C_{19}H_{16}Cl_2N_3NaO_9S_2H_2O$	510.32	CAD
-------	-----------------------------------	--------	-----

Dicloxacillin is a narrow spectrum β -lactam antibiotic of the penicillin class. It is used to treat infections caused by susceptible Gram-positive bacteria. Notably, it is active against β -lactamase-producing organisms such as Staphylococcus aureus, which would otherwise be resistant to most penicillins. It is very similar to flucloxacillin and these two agents are considered interchangeable. Dicloxacillin is available under a variety of trade names. **CAS 13412-64-1.**

2-(4-Diethylamino-2-hydroxy-benzoyl)-benzoic acid hexylester

D-062	$C_{24}H_{31}NO_4$	366.24	SU, EP, EPE
-------	--------------------	--------	-------------

The UV-A sun filter 2-(4-Diethylamino-2-hydroxybenzoyl)-benzoic acid hexylester provides efficient protection in the long-wave UVA-I range with an absorption spectrum of up to 400 nm it provides high absorption specifically in the deep-acting wavelengths. Uvinul A+. Diethylamino Hydroxybenzoyl Hexyl Benzoate. **CAS 302776-68-7.**

Art. No.	Formula	FW	Series
Di(ethylene glycol) diacrylate			
D-009	$C_{10}H_{14}O_5$	214.21	MP

A cross-linking acrylate monomer for use in coatings, adhesives, and printing plates of prepolymer type. Also known as DEGDA. **CAS** 4074-88-8.

Diethylenetriamine

D-010	$C_4H_{13}N_3$	103.17	E
-------	----------------	--------	---

Used as hardener for epoxy resins. Also known as DETA. **Cross: ethylenediamine dihydrochloride. CAS** 111-40-0.

DIETHYLHEXYL BUTAMIDO TRIAZONE

D-063	$C_{44}H_{59}N_7O_5$	765.50	SU, EP, EPE
-------	----------------------	--------	-------------

A sun filter for use in sunscreen products. Also known as Diocetyl butamido triazone and Uvasorb HEB. **CAS** 154702-15-5.

N,N-DIETHYL-p-PHENYLENEDIAMINE SULFATE

Deleted 2018

N,N'-Diethylthiourea

D-039	$(C_2H_5NH)_2CS$	132.25	R, SH
-------	------------------	--------	-------

An accelerator for mercaptanmodified chloroprene rubber. Used as antidegradant for natural, nitrile-butadiene, styrene-butadiene, and chloroprene rubbers. Also available as part of Mx-24 and Mx-27. **CAS** 105-55-5.

N,N-DIETHYLTOLUENE-2,5-DIAMINE HCL

Deleted 2018

Art. No.	Formula	FW	Series
Diltiazem hydrochloride			
D-060	$C_{22}H_{26}N_2O_4SHCl$	450.98	CAD

Diltiazem HCl is a member of the group of drugs known as benzothiazepines, which are a class of calcium channel blockers, used in the treatment of hypertension, angina pectoris, and some types of arrhythmia. It is a class 3 anti-anginal drug, and a class IV antidysrhythmic. It incites very minimal reflex sympathetic changes. **CAS** 33286-22-5.

DIMETHYLAMINOETHYL METHACRYLATE

D-045	$C_8H_{15}NO_2$	157.21	DS, MA, DMP
-------	-----------------	--------	-------------

Used as amine activator in visible light-cured dental acrylic composite materials. Also known as N,N-Dimethylaminoethyl methacrylate. **CAS** 2867-47-2.

3-(Dimethylamino)-1-propylamine

D-053	$C_9H_{14}N_2$	102.18	C, E, AC
-------	----------------	--------	----------

This is an intermediate substance in the synthesis of alkylamidopropyldimethylamines/alkylamidobetaines and found as an impurity in cosmetic surfactants present in e.g. shampoos. 3-(Dimethylamino)propylamine is also used as a hardener of epoxy resins, as an additive in fuel, dyes, pesticides and binding agents. It is also used in the production of ion-exchangers. Also known as DMPA. **CAS** 109-55-7.

Dimethyl dihydroxy ethylene urea

D-052			TF
-------	--	--	----

A non-Formaldehyde type of textile resin for "wash and wear" colored and white fabrics and shirtings, draperies and sheeting. Chlorine resistant. (Fixapret NF).

Dimethyl fumarate

D-066	$C_6H_8O_4$	144.12	SH
-------	-------------	--------	----

This compound is used as an antifungal substance in products such as sofas, helmets, clothes etc. It is packed normally in pads where the substance sublimates and might penetrate leather etc. **CAS** 624-49-7

Art. No.	Formula	FW	Series
Dimethylol dihydroxy ethylene urea			
D-012	C ₅ H ₁₀ N ₂ O ₅	178.14	TF

A formaldehyde type of textile resin (Fixapret CPN, 74% active component). Also available as part of Mx-16.

Dimethylol dihydroxy ethylene urea, modified			
D-050			TF

A low-Formaldehyde type of textile resin for "wash and wear" colored and white fabrics and shirtings, Viscose and mixtures with synthetic materials. (Fixapret ECO).

4,4-Dimethyl-oxazolidine

Comp. in D-015	C ₅ H ₁₁ NO	101.15	O
----------------	-----------------------------------	--------	---

Used as a preservative for latex paints, emulsions and for cooling fluids (component in Bioban CS 1135 by 74.7%). D-015: **Bioban CS 1135** also contains 3,4,4-Trimethyloxazolidine. Neither of the substances can be ordered separately. Also known as DIMETHYL OXAZOLIDINE. **CAS** 51200-87-4.

N,N-Dimethyl-4-toluidine

D-016	C ₉ H ₁₃ N	135.21	DS
-------	----------------------------------	--------	----

An amine accelerator for the polymerization of e.g. dental methacrylic restorative materials. **CAS** 99-97-8.

N,N-Di-2-naphtyl-4-phenylenediamine

D-017	C ₂₆ H ₂₀ N ₂	360.46	R
-------	--	--------	---

An antidegradant for latex, nitrile rubber, styrene-butadiene, and nitrile-butadiene rubber Also known as DBNPD. **CAS** 93-46-9.

Diocetyl phtalate

D-018	C ₂₄ H ₃₈ O ₄	390.57	PG
-------	--	--------	----

Used as plasticizer in various plastic materials. Also known as Diethylhexyl phthalate, DEHP and DOP. **CAS** 117-81-7.

Art. No.	Formula	FW	Series
Dipentamethylenethiuram disulfide			
D-019	(C ₅ H ₁₀ NCS ₂) ₂	320.60	S, IS, R

Used as accelerator and vulcanizing agent for latex (gloves) and butyl rubber. Also known as PTD. Also available as part of Mx-01. **CAS** 94-37-1.

Diphenhydramine hydrochloride

D-021	C ₁₇ H ₂₂ ClNO	291.82	ME
-------	--------------------------------------	--------	----

An antihistaminic drug which blocks the effect of histamine at H1 receptor sites, which results in an increase in vascular smooth muscle contraction. It has also been shown to have inhibitive tumor promotion properties. **PA. CAS** 147-24-0.

1,3-Diphenylguanidine

D-022	C ₁₃ H ₁₃ N ₃	211.27	ICB, R, SH, NA, NAE, NAC, AC
-------	--	--------	------------------------------

A medium accelerator for use with thiazoles and sulfenamides in various rubber products. Also available as part of Mx-06. **CAS** 102-06-7.

Diphenylmethane-4,4'-diisocyanate

D-023	C ₁₅ H ₁₀ N ₂ O ₂	250.26	I
-------	---	--------	---

A diisocyanate in the production of polyurethane lacquers, foam plastics, rubber, and glues. Also known as MDI. **CAS** 101-68-8.

N,N'-Diphenyl-p-phenylenediamine

D-024	C ₁₈ H ₁₆ N ₂	260.34	R
-------	--	--------	---

Used as antidegradant for nitrile-butadiene rubber, natural, styrene-butadiene, isoprene, butadiene, and chloroprene rubbers. Also known as DPPD. Also available as part of Mx-04. **CAS** 74-31-7.

N,N'-Diphenylthiourea

D-025	C ₁₃ H ₁₂ N ₂ S	228.32	PG, R, SH
-------	--	--------	-----------

An accelerator and activator for neoprene rubber and ethylene-propylene-diene terpolymers used for rubber products such as wet suits, goggles, knee brace and gloves. In sulfur dyes and as

Art. No.	Formula	FW	Series
heat stabilizer in PVC adhesive tape backing. Also known as Thiocarbanilide and DPTU. Also available as part of Mx-27. CAS 102-08-9.			

Direct Orange 34

D-051			TF
-------	--	--	----

An azo dye (stilbene) belonging to the direct dye class for coloring cellulosic textiles.

Disodium phenyl dibenzimidazole tetrasulfonate

D-064	$C_{20}H_{12}N_4Na_2O_{12}S_4$	674.59	SU, EPE
-------	--------------------------------	--------	---------

A sun filter used in sunscreen products. Also known as: Neo Heliopan AP, Bisimidazylate and 2,2'-(1,4-Phenylene)bis-(1-H-benzimidazole-4,6-disulfonic acid, monosodium salt). **CAS** 180898-37-7.

DISPERSE BLUE 3

D-026	$C_{17}H_{16}N_2O_3$	296.33	TF
-------	----------------------	--------	----

A textile dye of anthraquinone type. Used as dye for nylon, acrylic, polyester and acetate. Also used as stocking dye. **CAS** 2475-46-9.

Disperse Blue 35

D-027		362.34	TF
-------	--	--------	----

Textile dye of anthraquinone type. Dye in nylon, acrylic, polyester, and acetate. Also available as part of Mx-30. **PT. CAS** 12222-75-2.

Disperse Blue 85

D-028			TF
-------	--	--	----

A textile dye of azo type.

Disperse Blue 106

D-040			TF
-------	--	--	----

A monoazo dye used for secondary cellulose fabrics (polyester blouses, garment linings, etc.) Also available as part of Mx-26 and Mx-30. **CAS** 68516-81-4.

Art. No.	Formula	FW	Series
----------	---------	----	--------

Disperse Blue 124

D-041	$C_{15}H_{21}N_5O_4S$	367.47	TF
-------	-----------------------	--------	----

Am azo dye used for secondary cellulose acetate fabrics (stockings, garment linings, etc.). Also available as part of Mx-26 and Mx-30. **CAS** 61951-51-7.

Disperse Blue 153

Deleted 2019

A textile dye of anthraquinone type.

Disperse Brown 1

D-030	$C_{16}H_{15}Cl_3N_4O_4$	433.68	TF
-------	--------------------------	--------	----

A textile dye of azo type.

Disperse Orange 1

D-031	$C_{18}H_{14}N_4O_2$	318.34	TF
-------	----------------------	--------	----

A textile dye of azo type. Dye in terylene. Also available as part of Mx-30. **CAS** 2581-69-3.

DISPERSE ORANGE 3

D-032	$C_{12}H_{10}N_4O_2$	242.24	AC,ICB,SH,TF,NAC
-------	----------------------	--------	------------------

A textile dye of azo type. Also available as part of Mx-30. **CAS** 730-40-5.

Disperse Red 1

D-034	$C_{16}H_{18}N_4O_3$	314.35	TF
-------	----------------------	--------	----

A textile dye of azo type. Used to dye nylon and polyester. Also used as stocking dye. Also available as part of Mx-30. **CAS** 2872-52-8.

DISPERSE RED 17

D-035	$C_{17}H_{20}N_4O_4$	344.37	TF
-------	----------------------	--------	----

A textile dye of azo type. Used to dye acetate, silk, wool, and cotton. Also used as stocking dye. Also available as part of Mx-30. **CAS** 3179-89-3.

Art. No.	Formula	FW	Series
Disperse Yellow 3			
D-036	$C_{15}H_{15}N_3O_2$	269.31	ICB, TF, NAC

A textile dye of azo type. Used to dye acetate and nylon. Also used as stocking dye. Also available as part of Mx-30. **CAS** 2832-40-8.

Disperse Yellow 9			
D-037	$C_{12}H_{10}N_4O_4$	274.24	TF

A textile dye of nitro type. Used to dye in terylene. **CAS** 6373-73-5.

4,4'-Dithiodimorpholine			
D-054	$C_8H_{16}N_2O_2S_2$	236.35	SH, R

A vulcanizing agent and promoter of natural and synthetic rubber, it can release the sulphur in the vulcanizing temperature. It can be used in the butyl rubber to produce tyre, butyl inner tube of tire, rubber belt and anti-heat rubber products, it also can be used as pitch stabilizer in the expressway. Also known as DTDM. **CAS** 103-34-4.

DMDM HYDANTOIN			
D-047	$C_7H_{12}N_2O_4$	188.07	ICB, C, NA, NAE, NAC, AC

Functions as a formaldehyde donor and is used as a preservative in cosmetic products and is active against fungi, yeasts, and bacteria. Products preserved are of the type shampoos, skin-care products, hair conditioners, makeup, hair rinses, and cleanliness products. Also used in herbicides, polymers, color photography, latex paints, floor waxes, cutting oils, adhesives, copying paper, inks.

DODECYL GALLATE			
D-042	$C_{19}H_{30}O_5$	338.45	B, C

An antioxidant in cosmetic and pharmaceutical creams and emulsions, various fats, oils, waxes, and foods such as margarine. Also known as Lauryl gallate. Also available as part of Mx-28B. **CAS** 1166-52-5.

Art. No.	Formula	FW	Series
Dodecyl mercaptan			
D-043	$C_{12}H_{26}S$	202.41	R, SH

A polymerization inhibitor added to polyurethane resins and Neoprene glues for use, e.g., in the shoe industry. **CAS** 112-55-0.

Doxycycline monohydrate			
D-059	$C_{22}H_{24}N_2O_8 \cdot H_2O$	462.45	CAD

A semisynthetic broad-spectrum antibiotic or antibacterial which belongs to the tetracycline family. It is used to treat urinary tract infections, gum disease, and bacterial infections such as gonorrhoea, chlamydia and Bacillus anthracis. It is also used to treat acne. **CAS** 17086-28-1.

DROMETRIZOLE			
H-016	$C_{13}H_{11}N_3O$	225.25	C, DS, PG, DMP

An UV-adsorber used in plastics, cosmetics, dental materials, acrylic materials, dyes, etc. Also known as 2-(2-Hydroxy-5-methylphenyl) benzotriazol, Tinuvin P. **CAS** 2440-22-4.

DROMETRIZOLE TRISILOXANE			
D-055	$C_{24}H_{39}N_3O_3Si_3$	501.84	SU, EP, EPE

An UV-B adsorbing agent in sunscreen cosmetics of the type creams, lotions, lipsticks, sun oils, etc. Trade name is Silatrizole & Mexoryl XL. Also known as 2-(2H-Benzotriazole-2-yl)-4-methyl-6-[2-methyl-3-[1,3,3'-tetramethyl-1-[(trimethylsilyloxy]disiloxanyl]propyl]phenol. **CAS** 155633-54-8.

E

Econazole nitrate			
E-021	$C_{18}H_{16}Cl_3N_3O_4$	444.69	ME

An antifungal agent of the imidazole type used in topical and vaginal preparations to prevent growth of dermatophytes, yeast, and mold. **Cross: miconazole, nilconazole. May produce erythema multiforme like eruptions. CAS** 24169-02-6.

Art. No.	Formula	FW	Series
Eosin			
E-022	$C_{20}H_8Br_4O_5$	647.90	LU

Red dye belonging to the xanthene group. Used as coloring agent in nail polish, wool, silk, and paper. It is now approved by the FDA for use in inks, drugs, and cosmetics except for eye cosmetics, and as topical low concentrated antiseptics. Also known as 2',4',5',7'-Tetrabromofluorescein. **CAS** 15086-94-9.

Epoxy acrylate

Deleted 2019

An acrylate oligomer for use in UV-reactive inks and varnishes.

Epoxy resin, Bisphenol A

E-002

S, ICB, SH, IS,
DMP, ECB, NA
AC, NAE, NAC, LA

A resin, based on epichlorhydrin and bisphenol A, used in adhesives, surface coatings, electrical insulation, plasticizers, polymer stabilizers, laminates, surface coatings, paints and inks, product finishers, PVC products, vinyl gloves, etc. Also found in the building industry, electron microscopy, and sculptures. Oligomers may vary in molecular weight from 340 and higher. The higher the molecular weight, the less sensitizing the compound. **May produce erythema multiforme like eruptions. May cause airborne contact dermatitis. UCU.**

Epoxy resin, Bisphenol F

B-035

E

A resin, based on Epichlorhydrin and Bisphenol F, used in adhesives, casting and tooling, epoxy coatings, coil coatings, marine and protective coatings, potting and encapsulation. Typical uses include compositions for the building and civil engineering industries, e.g. flooring compounds, adhesives, mortars and grouts. Often used in combination with Bisphenol A liquid epoxy resin. Also known as EPIKOTE Resin 862. **CAS** 28064-14-4.

Art. No.	Formula	FW	Series
Epoxy resin, cycloaliphatic			
Deleted 2019			

A resin based on diglycidyl ester of hexahydrophthalic acid. Its main use is for the manufacture of electrical insulating components (bushings, apparatus parts, insulators).

Erythromycin base

E-024	$C_{37}H_{67}NO_{13}$	733.94	CAD
-------	-----------------------	--------	-----

A macrolide antibiotic that has an antimicrobial spectrum similar to or slightly wider than that of penicillin, and is often used for people that have an allergy to penicillins. For respiratory tract infections, it has better coverage of atypical organisms, including mycoplasma and Legionellosis. It is also used to treat outbreaks of chlamydia, syphilis, acne, and gonorrhoea. Erythromycin is produced from a strain of the actinomycete *Saccharopolyspora erythraea*, formerly known as *Streptomyces erythraeus*. **CAS** 114-07-8.

Etofenamate

E-025	$C_{18}H_{18}F_3NO_4$	369.33	EP, EPE
-------	-----------------------	--------	---------

A NASID used for the treatment of joint and muscular pain. It acts by inhibiting the body's production of prostaglandin. **CAS** 30544-47-9.

7-ETHYLBICYCLOOXAZOLIDINE

A-017	$C_7H_{13}NO_2$	143.18	O
-------	-----------------	--------	---

A preservative in cooling fluids. Trade name, Bioban CS 1246. **CAS** 7747-35-5.

Ethyl acrylate

E-004	$C_5H_8O_2$	100.12	ICB, MN, MP, AC,NA, NAE, NAC
-------	-------------	--------	---------------------------------

An acrylic monomer used in the production of textile and paper coatings, leather finish resins, and adhesives. Also known as EA. **CAS** 140-88-5.

Art. No.	Formula	FW	Series
ETHYL CYANOACRYLATE			
E-023	C ₆ H ₇ NO ₂	125.10	MA, AC

A acrylate compound used in instant glues to mend broken nails and to adhere glue-impregnated silk or linen to the nail plate, which is then filed to shape the nail. Instant glues are also used in medicine to glue tissues and skin cracks. The glue is also used to attach hair and to glue shoes, plastics, and many other materials. Also known as Rite-Lok, Super Glue, Crazy Glue. **May cause airborne contact dermatitis. CAS 7085-85-0.**

Ethylenediamine dihydrochloride

E-005	C ₂ H ₁₀ Cl ₂ N ₂	133.02	ICB, C, E, P, O, AC, NA, NAE, NAC
-------	---	--------	--------------------------------------

A stabilizer in steroid creams and rubber latex. Used as inhibitor in antifreeze solutions and cooling fluids and an epoxy curing agent. May also be present in floor-polish removers. Found as component in nystatin cream and aminophylline. Used as accelerator in color development baths in photography. Used also in veterinary preparations, electroplating and electrophoretic gels, dyes, fungicides, insecticides, synthetic waxes, textile lubricants, eye and nose drops, and as solvent for casein, albumin, shellac. Also known as EDA. **Cross: EDTA, antazoline, aminophylline, promethazine HCl, piperazine. May produce erythema multiforme like eruptions. UCU. CAS 333-18-6**

Ethylenediamine tetraacetic acid disodiumsalt dihydrate

E-006	C ₁₀ H ₁₄ N ₂ Na ₂ O ₈ 2H ₂ O	372.24	
-------	--	--------	--

Used as a chelating agent for metals and as pharmaceutical aid (chelating agent). Also used as preservative in cosmetic products and anticoagulant. **CAS 6381-92-6.**

Ethylene glycol dimethacrylate

E-007	C ₁₀ H ₁₄ O ₄	198.22	DS, MA, MN, MP, DMP, DMS
-------	--	--------	-----------------------------

A cross-linking methacrylic monomer in dental composites, sealants, prostheses, adhesives, artificial nails, printing inks, etc. Also known as EGDMA. **May cause airborne contact dermatitis. CAS 97-90-5.**

Art. No.	Formula	FW	Series
Ethylene urea			

Deleted 2018

2-Ethylhexyl acrylate

Deleted 2021	C ₁₁ H ₂₀ O ₂	184.28	
--------------	--	--------	--

An acrylic monomer for use in UV-curable coatings and inks. Ingredient in some acrylic-based adhesive tapes. Also known as EHA. **CAS 103-11-7.**

ETHYLHEXYL DIMETHYL PABA

E-018	C ₁₇ H ₂₇ NO ₂	277.41	SU
-------	---	--------	----

An UV-B absorbing agent in sunscreens and cosmetic creams, lotions, lipsticks, sun oils, moisturizers, nail polish, etc. Also known as Eusolex 6007, Escalol 507, Octyldimethyl-PABA and 2-Ethylhexyl-4-dimethylaminobenzoate. **CAS 21245-02-3.**

ETHYLHEXYL METHOXYCINNAMATE

E-019	C ₁₈ H ₂₆ O ₃	290.18	AC,SU,EP,EPE
-------	--	--------	--------------

An UV-B absorbing agent in sunscreens and cosmetic creams, lotions, lipsticks, sun oils, etc. Also known as Parsol MCX and Escalol 557. **CAS 5466-77-3.**

ETHYLHEXYL SALICYLATE

O-007	C ₁₅ H ₂₂ O ₃	250.34	ICB, SU, EPE, NAC
-------	--	--------	----------------------

An UV-B adsorbing agent in sunscreen cosmetics of the type creams, lotions, lipsticks, sun oils, etc. Also known as Octyl salicylate, 2-Ethylhexyl salicylate and trade name is Escalol 587. **CAS 118-60-5.**

ETHYLHEXYL TRIAZONE

O-010			SU, EP, EPE
-------	--	--	-------------

An UV-B adsorbing agent in sunscreen cosmetics of the type creams, lotions, lipsticks, sun oils, etc. Also known as 2,4,6-trianilino-p-(carbo-2-ethylhexyl-1-oxi)-1,3,5-triazine. Trade name is Uvinyl T 150. **CAS 88122-99-0.**

Art. No.	Formula	FW	Series
ETHYLHEXYLGLYCERIN			
E-027	C ₁₁ H ₂₄ O ₃	204.3	C, AC

This substance is a topical skincare ingredient and deodorizing agent, often indicated as a conditioning ointment in the treatment of eczema. It can services as a surfactant and preservative-enhancer and can be found as a substituent for parabens. The chemical is a synthetic compound derived from vegetable glycerin. **CAS** 70445-33-9.

ETHYLPARABEN

E-010	C ₉ H ₁₀ O ₃	166.17	
-------	---	--------	--

A preservative used in foods (salad dressings, mayonnaise, spiced sauces, mustard, frozen dairy products, baked products), cosmetics, and pharmaceutical preparations. Also known as Ethyl-4-hydroxybenzoate. Also available as part of Mx-03A, Mx-03C. **CAS** 120-47-8.

N-Ethyl-N-(2-hydroxyethyl)-2-methyl-1,4-phenylene-diamine sulfate salt

Deleted 2018

ETHYL METHACRYLATE

E-012	C ₆ H ₁₀ O ₂	114.15	MN, MP
-------	---	--------	--------

A methacrylic monomer for use in, e.g., artificial nail products, dentures, hearing aids, printing plates, and bone cement. Also known as Ethyl methacrylate and EMA. **CAS** 97-63-2.

N-Ethyl-N-(2-methane-sulfonamidoethyl)-2-methyl-1,4-PPD-sesquisulfate, hydrate, (CD-3)

Deleted 2018

Art. No.	Formula	FW	Series
4,4-(2-Ethyl-2-nitro-trimethylene)dimorpholine			
Comp. in E-014	C ₁₃ H ₂₅ N ₃ O ₄	287.36	O

A preservative used in cooling fluids, crude oil, diesel fuel, heating oil, etc. 4,4-(2-Ethyl-2-nitro-trimethylene)dimorpholine is present in Bioban P 1487 (trade name) by 20 %. Bioban P 1487 also contains 4-(2-Nitrobutyl) morpholine. Neither of the substances can be ordered separately. **CAS** 37304-88-4.

N-Ethyl-p-toluenesulfonamide

E-015	C ₉ H ₁₃ NO ₂ S	199.27	DS, DMP
-------	--	--------	---------

A resin carrier found in dental materials used for isolating cavities below restorations. Plasticizer in PVA lacquers, polyamides, cellulose acetate etc. **CAS** 80-39-7.

EUGENOL

E-016	C ₁₀ H ₁₂ O ₂	164.21	B, DS, F, DMP, DMS
-------	--	--------	--------------------

Used as fragrance in perfumery as substitute for oil of Cloves. Dental analgesic in impression materials and periodontal packings. Used in the production of Vanillin. Also used as insect attractant. Also available as part of Mx-07. **May elicit contact urticaria. Cross: Peru balsam, isoeugenol, benzoin, propanidid. CAS** 97-53-0.

Evernia furfuracea

Change of name as of January 2016; please refer to Treemoss absolute (Art. No. E-026).

Evernic acid

E-017	C ₁₇ H ₁₆ O ₇	332.32	PL
-------	--	--------	----

An acid present in different lichens. One of the three most common lichen haptens. Also available as part of Mx-15. **Cross: oak moss. PA. CAS** 537-09-7.

Art. No.	Formula	FW	Series
----------	---------	----	--------

F

FARNESOL

F-004	$C_{15}H_{26}O$	222.37	F
-------	-----------------	--------	---

A fragrance used in various perfumed products. FARNESOL is a nature identical ingredient originally found in orange blossoms, rose, jasmin or linden flowers. It inhibits the bacterial activity responsible for unpleasant odors, acne and the athlete's foot, while at the same time not affecting the natural skin flora. Also used as a pesticide. Also known as 3,7,11-trimethyl-2,6,10-dodecatrien-1-ol. Also available as part of Mx-25. **CAS** 4602-84-0.

Fenofibrate

F-006	$C_{20}H_{21}ClO_4$	360.83	EPE
-------	---------------------	--------	-----

A drug of the fibrate class, mainly used to reduce cholesterol levels in patients at risk of cardiovascular disease. Like other fibrates, it reduces both low-density lipoprotein (LDL) and very low density lipoprotein (VLDL) levels, as well as increasing high-density lipoprotein (HDL) levels and reducing triglycerides level. **CAS** 49562-28-9.

FERRIC CHLORIDE

I-016	Cl_3Fe	162.2	MET
-------	----------	-------	-----

This hapten is a marker for contact allergy to **iron**. Also generally known as Iron(III)chloride, is an industrial scale commodity chemical compound. In industrial application used in sewage treatment and drinking water production. It is necessary for the etching of photogravure plates for printing photographic and fine art images in intaglio and for etching rotogravure cylinders used in the printing industry. Also used in veterinary practice. **CAS** 7705-08-0.

Art. No.	Formula	FW	Series
----------	---------	----	--------

FORMALDEHYDE

F-002	CH_2O	30.03	S, ICB, DS, H, LA O, SH, IS, ECB, AC, NA, NAE, NAC,
-------	---------	-------	---

Used in the production of urea, phenolic melamine and acetale resins. Found in textile products. Used as astringent, disinfectant, preservative in cosmetics, metalworking fluids, shampoos, etc. Other exposure areas include antiperspirant in cosmetics, anticracking agent in dental plastics, anhidrotics, chipboard production, cleaning products, disinfectants and deodorizers, dry-cleaning materials, glues, mineral wool production, paints and coatings, paper industry, phenolic resins and urea plastics in adhesives and footwear, photographic paper and solutions, polishes, printing materials, tanning agents, wart remedies, embalming solutions, fertilizers, wood composites, insulation. Formaldehyde releasers: Bakzid P, Biocide DS 5249, Bronopol, Dantoin MDMH, DMDM HYDANTOIN, Dowicil 200, Germall 115, Germall II, Grotan BK, Hexamethylenetetramine, KM 103, Paraformaldehyde, Parmetol K50, Polyoxymethylene urea, Preventol D1, -D2, -D3. **Cross: aryl-sulfonamide resin, chloroallyl-hexaminium chloride. May produce erythema multiforme like eruptions. PA. PT. May cause airborne contact dermatitis. NICU. CAS** 50-00-0.

Framycetin sulphate

F-005	$C_{23}H_{46}N_6O_{13}H_2SO_4$	712.72	LU, ME
-------	--------------------------------	--------	--------

A broad spectrum aminoglycoside antibiotic, is usually bactericidal in action. For local use in the treatment of infections caused by pyogenic organisms, in particular *S. aureus*, the proteus group of bacteria, coliforms and *P. aeruginosa*. Cross sensitization may occur among the group of Streptomyces derived antibiotics (neomycin, paromomycin, kanamycin) of which framycetin is a member, but this is not invariable. Also known as Neomycin B, Framycetin, Soframycin. **ICU. CAS** 4146-30-9.

Fusidic acid sodium salt

F-003	$C_{31}H_{47}NaO_6$	538.70	ICB, ME, LU, NAE, NAC
-------	---------------------	--------	--------------------------

An antibiotic agent used in the treatment or prevention of cutaneous infections, mainly *Staphylococcus aureus*. Contact dermatitis often associated with treatment of leg ulcers or atopic dermatitis. **CAS** 751-94-0.

Art. No.	Formula	FW	Series
----------	---------	----	--------

G

Gallium(III)oxide

G-007	Ga ₂ O ₃	187.44	MET
-------	--------------------------------	--------	-----

This hapten is a marker for contact allergy to **gallium**. This is a chemical compound used as part of the manufacturing of semiconductor devices. It might also be found in dental implants. **CAS** 12024-21-4.

Gentamicin sulfate

G-006	C ₁₉₋₂₁ H ₃₉₋₄₃ N ₅ O ₇ ·2.5H ₂ SO ₄		ME
-------	---	--	----

A topical and systemic broad-spectrum antibiotic with bactericidal action. Also used in ophthalmic drugs. **Cross: neomycin sulfate**. **CAS** 1405-41-0.

GERANIOL

G-001	C ₁₀ H ₁₈ O	154.25	F
-------	-----------------------------------	--------	---

As fragrance in perfumery. As insect attractant. Also available as part of Mx-07. **CAS** 106-24-1.

Geranium oil

G-002			F
-------	--	--	---

A fragrance used in various perfumes. Used as odorant for tooth and dusting powders, ointments, etc. The raw material for this product is made from a steam distillation of the whole plant of Pelargonium graveolens. Contains among other substances DL-Citronellol, Geraniol, Linalool, Menthone and Citral. Also known as Geranium oil Bourbon. **CAS** 8000-46-2.

Geranium oil Bourbon

Change of name as of January 2016; please refer to Geranium oil (Art. No. G-002).

Art. No.	Formula	FW	Series
----------	---------	----	--------

GLUTARAL

G-003	C ₅ H ₈ O ₂	100.12	ICB, DS, P, SH, DMS, NA, NAE, NAC
-------	--	--------	---

Used in the sterilization of endoscopic instruments, dental and barber equipment. Used as embalming fluid, in electron microscopy. A tanning agent for leather. A hardener for photographic gelatin. A pharmacological agent used for hyperhidrosis and antifungal purposes and for treatment of warts and some bullous diseases as well as herpes infections. Also known as Glutaraldehyde. **May cause airborne contact dermatitis**. **CAS** 111-30-8.

GLYCERYL THIOGLYCOLATE

G-004	C ₅ H ₁₀ SO ₄	166.22	ICB, H, NAC
-------	--	--------	-------------

A component in "acid" permanent waving formulations, mainly for use in hairdressing salons. **CAS** 30618-84-9.

Gold(I)sodium thiosulfate dihydrate

G-005	AuNa ₃ (S ₂ O ₃) ₂ ·2H ₂ O	526.27	ICB, DS, MET, DMP, NAC, AC
-------	--	--------	-------------------------------

A gold derivative used for screening of contact allergy to dental gold materials. **CAS** 10233-88-2.

H

Hexachlorophene

H-001	C ₁₃ H ₆ Cl ₆ O ₂	406.91	6
-------	---	--------	---

Atopical antiseptic in germicidal soaps, creams, deodorants, cleansers, shampoos, after-shave creams, pHisoHex surgical cleanser. **Cross: bithionol, halogenated salicylanilides**. **PA**. **CAS** 70-30-4.

Hexahydro-1,3,5-tris-(2-hydroxyethyl)triazine

H-002	C ₉ H ₂₁ N ₃ O ₃	219.29	C, O
-------	--	--------	------

A bactericide used in cooling fluids and various cosmetic products, acting as formaldehyde liberator. Active component in **Grotan BK**. **CAS** 4719-04-4.

Art. No.	Formula	FW	Series
Hexamethylene diisocyanate			
H-022	C ₈ H ₁₂ N ₂ O ₂	168.20	I

An isocyanate monomer in polyurethane paints and lacquers. Also known as HDI. **CAS** 822-06-0.

1,6-Hexanediol diacrylate

H-004	C ₁₂ H ₁₈ O ₄	226.28	DS, MA, MN, MP, DMP
-------	--	--------	------------------------

A common acrylic monomer in UV-cured inks, adhesives, coatings, photoresists, castings, artificial nails, etc. Also known as HDDA. A monomer in dental composite materials. **CAS** 13048-33-4.

1,6-Hexanediol diglycidylether

Deleted 2021	C ₁₂ H ₂₂ O ₄	230.30	
--------------	--	--------	--

Used as a general purpose diluent to reduce viscosity of epoxy resins, favoring improved filler loading and substrate wetting and resulting in faster curing time. End applications include coating, adhesive, casting, laminating, encapsulation or foam. It is also used as a stabilizer for chlorinated vinyl resins and rubber. Also known as 2,2'-(1,6-hexanediylbis(oxymethylene))bis-oxirane. **CAS** 16096-31-4.

Hexyl cinnamic aldehyde

H-025	C ₁₅ H ₂₀ O	216.35	F
-------	-----------------------------------	--------	---

A fragrance used in various perfumed products. Odor profile: floral, jasmin, waxy. Olfactory description: Similar to α-amyl cinnamic aldehyde but with a finer, more floral and delicate character. Found in acid cleaner liquid, detergent TAED, alcoholic lotion, fabric softener, anti perspirant, bath foam, bleach, hard surface cleaner, deo-stick shampoo, detergent perborate and soap. Also known as α-Hexylcinnamaldehyde. Also available as part of Mx-25. **CAS** 101-86-0.

HOMOSALATE

H-024	C ₁₆ H ₂₂ O ₃	262.35	SU, EPE
-------	--	--------	---------

An UV adsorbing agent found in sunscreen cosmetics of the type creams, lotions, lipsticks, sun oils, etc. Found in e.g. Coppertone products. Also known as 3,3,5-trimethylcyclohexyl salicylate. **CAS** 118-56-9.

Art. No.	Formula	FW	Series
Hydantoin			
H-027	C ₃ H ₄ N ₂ O ₂	100.08	CAD

Hydantoin, also known as glycolyurea, is an imidazole analogue. Hydantoin and its derivatives are used in the preparation of textile softeners, lubricants, resins, and agrochemicals. They have antibacterial, antifungal, antiprotozoal, and anthelmintic activity. They are used in manufacturing pharmaceuticals especially anticonvulsant drugs such as phenytoin, ethotoin, and methyphenytoin. **CAS** 461-72-3.

Hydrazine sulfate

H-005	H ₆ N ₂ O ₄ S	130.12	O
-------	--	--------	---

Used as flux for soldering brass, copper, aluminium, and other metals. Also used as pressure stabilizer in cutting oils. **May cause airborne contact dermatitis.** **CAS** 10034-93-2.

HYDROABIETYL ALCOHOL

A-002	C ₂₀ H ₃₄ O	290.54	C, PG
-------	-----------------------------------	--------	-------

An organic alcohol derived from wood rosin. Used in adhesives, mascara, inks, sealants, etc. Also used as plasticizer in plastic materials. Also known as Abitol. **CAS** 13393-93-6.

Hydrochlorothiazide

H-029	C ₇ H ₈ ClN ₃ O ₄ S ₂	297.73	CAD
-------	--	--------	-----

Hydrochlorothiazide, sometimes abbreviated HCT, HCTZ, or HZT is a popular diuretic drug that acts by inhibiting the kidneys' ability to retain water. This reduces the volume of the blood, decreasing blood return to the heart and thus cardiac output and, by other mechanisms, is believed to lower peripheral vascular resistance. Hydrochlorothiazide is sold both as a generic drug and under a large number of brand names, including: Apo-Hydro, Aquazide H, Dichlotride, Hydrodiuril, HydroSaluric, Microzide, Oretic. **CAS** 58-93-5.

Hydrocortisone-17-butyrate

H-021	C ₂₅ H ₃₆ O ₆	432.62	CS, LA, AC
-------	--	--------	------------

Used as a topical corticosteroid with anti inflammatory properties. Marker for topical corticosteroid allergy. Also available as part of Mx-23. **Cross: Budesonide, Fluocinolone acetonide, Hydrocortisone, Prednisolone Acetate, Tixocortol-21-Pivalate, Triamcinolone acetonide.** **CAS** 13609-67-1

Art. No.	Formula	FW	Series
Hydrocortisone-21-acetate			
H-034	$C_{23}H_{32}O_6$	404.50	CS

Atopical corticosteroid with anti-inflammatory and immunosuppressive properties, belonging to the group A type of steroids. Used in medication to treat a variety of skin conditions (e.g., eczema, dermatitis, allergies, rash).

Cross: Budesonide, Fluocinolone acetonide, Hydrocortisone, Hydrocortisone 17-butyrate, Prednisolone acetate, Methylprednisolone aceponate, Tixocortol-21-pivalate, Triamcinolone acetonide. CAS 50-03-3

HYDROGEN PEROXIDE

Deleted 2019	H_2O_2	34.02	
--------------	----------	-------	--

A component in hair bleaches and a topical antiseptic agent.
CAS 7722-84-1.

Hydroperoxides of Limonene

H-032			ICB, B, F, O, ECB, NA, NAE, NAC, AC
-------	--	--	---

Limonene is found in cosmetics, fine fragrances and hygiene products as well as in household and industrial products. Limonene is one of the most commonly found fragrance ingredients in consumer products presently available. Limonene is a naturally occurring terpene, present in large amounts in various citrus fruits. Limonene autoxidize on air exposure at room temperature forming hydroperoxides. Compared to pure unoxidized limonene the hydroperoxides of oxidized limonene have shown to be far more allergenic. **NOTE: The preparation contains oxidized d-limonene. The concentration of the active haptens in the preparation is measured from the total amount of the hydroperoxides of d-limonene.**

Art. No.	Formula	FW	Series
Hydroperoxides of Linalool			
H-031			ICB, F, ECB, NA, NAE, NAC, AC

Linalool is found in fine fragrances, cosmetics, and hygiene products as well as in household and industrial products. Linalool is among the most commonly found fragrance ingredients in consumer products presently available. Linalool is a naturally occurring terpene, present in large amounts in various plants, for example in lavender, rosewood, bergamot and jasmine. Linalool autoxidize on air exposure at room temperature forming hydroperoxides. Compared to pure unoxidized linalool the hydroperoxides of oxidized linalool have shown to be far more allergenic. **NOTE: The preparation contains oxidized linalool. The concentration of the active haptens in the preparation is measured from the total amount of the hydroperoxides of linalool.**

HYDROQUINONE

H-007	$C_6H_6O_2$	110.11	H, PG
-------	-------------	--------	-------

A inhibitor in acrylic monomers, used as antioxidant e.g. in animal feed. Also used as photographic reducer and developer. Also known as HQ. **Cross: resorcinol. May cause depigmentation. CAS 123-31-9.**

Hydroquinone monobenzylether

H-019	$C_{13}H_{12}O_2$	200.23	SH
-------	-------------------	--------	----

A antidegradant added to rubber products. Used as inhibitor in acrylic resins. **May cause depigmentation. CAS 103-16-2.**

HYDROXYCITRONELLAL

H-008	$C_{10}H_{20}O_2$	170.25	F
-------	-------------------	--------	---

A fragrance used in various perfumes, antiseptics, insecticides and household products. Also known as Hydroxycitronellal. Also available as part of Mx-07. **Cross: citronellal, geranial, methoxy-citronellal. May produce hyperpigmentation. CAS 107-75-5.**

2-Hydroxyethyl acrylate

H-009	$C_5H_8O_3$	116.12	MN, MP
-------	-------------	--------	--------

An acrylic monomer used in UV-inks, adhesives, lacquers, artificial nails etc. Also known as HEA. **CAS 818-61-1.**

Art. No.	Formula	FW	Series
2-Hydroxyethyl methacrylate			
H-010	$C_6H_{10}O_3$	130.15	ECB, DMP, DMS, AC, DS, ICB, MA, MP, MN, NA, NAE, NAC, S

A methacrylic monomer used in UV-inks, adhesives, lacquers, dental materials, artificial nails etc. Also known as HEMA. **CAS** 868-77-9.

HYDROXYETHYL-p-PHENYLENEDIAMINE SULFATE

H-033	$C_8H_{12}N_2O \cdot H_2O_4S$	250.27	H
-------	-------------------------------	--------	---

This substance is a hair dye ingredient used in the formulation of permanent hair dyes and colors. **CAS** 93841-25-9.

HYDROXYISOHEXYL 3-CYCLOHEXENE CARBOXALDEHYDE

L-003	$C_{13}H_{22}O_2$	210.00	S, ICB, F, IS, LA, ECB, NAE, NAC, AC
-------	-------------------	--------	--------------------------------------

A fragrance known for its soft delicate floral, lily, cyclamen note reminiscent of hydroxycitronellal. Used in products such as Alcohol Lotion, Anti Perspirant, Deo Stick, Detergent Perborate, Detergent TAED, Fabric Softener, Hard Surface Cleaner, Shampoo and soap. Stabilized with 0.1% BHT. Also known as 3-cyclohexene-1-carboxaldehyde, 4-(4-hydroxy-4-methylpentyl)-3-cyclohexene-1-carboxaldehyde, HICC and Lyral. Also available as part of Mx-25. **CAS** 31906-04-4.

HYDROXYLAMINE HCL

Deleted 2018

HYDROXYLAMINE SULFATE

Deleted 2018

Hydroxypropyl acrylate

Deleted 2021	$C_6H_{10}O_3$	130.15	
--------------	----------------	--------	--

An acrylic monomer used in UV inks, lacquers, adhesives, etc. Also known as 2-Hydroxy-1-propylacrylate. **CAS** 25584-83-2.

Art. No.	Formula	FW	Series
Hydroxypropyl methacrylate			
H-018	$C_7H_{12}O_3$	144.17	MA, MN, MP

A monofunctional methacrylic monomer found in dental composites and sealants, UV-curable resins for inks etc. Also known as HPMA. **CAS** 27813-02-1.

Hydroxyzine hydrochloride

H-028	$C_{21}H_{27}ClN_2O_2 \cdot 2HCl$	447.83	CAD
-------	-----------------------------------	--------	-----

This substance is a first-generation antihistamine, of the piperazine class that is an H1 receptor antagonist. It is used primarily as an antihistamine for the treatment of itches and irritations, an antiemetic for the reduction of nausea, as a weak analgesic by itself and as an opioid potentiator, and as an anxiolytic for the treatment of anxiety. The drug is available in two formulations, the pamoate and the dihydrochloride or hydrochloride salts. Vistaril®, Equipose®, Masmoran®, Paxistil®, and Vistaril Pamoate® are preparations of the pamoate salt whilst Atarax®, Alamon®, Aterax®, Durrax®, Tran-Q®, Orgatrx®, Quiess®, Vistaril Parenteral®, and Tranquizine® are hydroxyzine hydrochloride. **CAS** 2192-20-3.

Ibuprofen

I-010	$C_{13}H_{18}O_2$	206.3	CAD, EPE
-------	-------------------	-------	----------

A NSAID originally marketed as Nurofen and since under various trademarks, including Act-3, Advil, Brufen, Dorival, Herron Blue, Panafen, Motrin, Nuprin and Burana, Ipren or Ibumetin, Ibuprom, IbuHEXAL, Ibusal, Fenpaed, Moment, Ibux, Ibúfen, Ibalgin, Bupuren, Neofen, Eve and Advil. It is used for relief of symptoms of arthritis, primary dysmenorrhoea, fever, and as an analgesic, especially where there is an inflammatory component. Ibuprofen has no antiplatelet (blood-thinning) effect. **CAS** 15687-27-1.

Art. No.	Formula	FW	Series
IMIDAZOLIDINYL UREA			
I-001	$C_{11}H_{16}N_8O_8$	388.31	ICB, C, H, IS, LU; ECB, NA, NAE, NAC, LA, AC

A preservative used in lotions, creams, hair conditioners, shampoos, deodorants and topical drugs. Works as a formaldehyde releaser. Also known as Germall 115, Imidurea NF, Sept 115, Unicide U-13, Tristat IU and Biopure 100. **CAS** 39236-46-9.

Imipenem monohydrate

Deleted 2018

Indium

I-015	In	114.82	MET
-------	----	--------	-----

Indium is a rare, soft, malleable and easily fusible poor metal. Its current primary application is to form transparent electrodes from indium tin oxide in liquid crystal displays. It is widely used in thin-films to form lubricated layers, it is also used for making particularly low melting point alloys, and is a component in some lead-free solders. It is sometimes present in dental alloys. **CAS** 7440-74-6.

Indium(III)chloride

I-011	Cl_3In	221.18	MET
-------	----------	--------	-----

This hapten is a marker for contact allergy to **indium**. This metal is a colorless salt and also the most available soluble derivative of indium. Indiclor Indium In-111 Chloride is a diagnostic radiopharmaceutical intended for radiolabeling ProstaScint (capromab pendetide) used for in vivo diagnostic imaging procedures and for radiolabeling Zevalin (ibritumomab tiuxetan) in preparations used for radioimmunotherapy procedures. **CAS** 10025-82-8.

Indium(III)sulfate

I-013	$In_2(SO_4)_3$	517.83	MET
-------	----------------	--------	-----

This hapten is a marker for contact allergy to **indium**. Indium sulfate is readily soluble in water for uses such as in water treatment. Indium sulfate is being marketed as a miracle dietary supplement and is falsely advertised as a dietary aid as an enhancer of food

Art. No.	Formula	FW	Series
and mineral absorption, an anti-aging supplement, a blood pressure lowering supplement. CAS 13464-82-9.			
IODOPROPYNYL BUTYLCARBAMATE			
I-008	$C_8H_{12}INO_2$	281.09	ICB, C, O, NA, NAE, NAC, AC

A compound used as fungicide and bactericide for wood and paint preservation and in cooling fluids. Now also permitted and used as a cosmetics preservative in products such as shampoos, lotions, creams, powders and baby products. Also known as Troysan KK-108a and under trade name Glycasil™. **CAS** 55406-53-6.

Iridium

I-014	Ir	192.22	MET
-------	----	--------	-----

Iridium is a dense, very hard, brittle, silvery-white transition metal of the platinum family. Iridium is notable for being the most corrosion-resistant element known. It is used in high-temperature apparatus, electrical contacts, but the principal use of iridium is as a hardening agent in platinum alloys. Other uses: Crucibles and devices that require high temperatures. Electrical contacts (notable example: Pt-Ir spark plugs). Used in high-dose-radiation therapy for the treatment of prostate and other forms of cancer. **CAS** 7439-88-5.

Iridium(III)chloride trihydrate

I-012	Cl_3Ir3H_2O	352.62	MET
-------	---------------	--------	-----

This hapten is a marker for contact allergy to **iridium**. Iridium(III) chloride trihydrate is the principal starting material for most iridium chemistry. Among other uses it is used in the production of hydrogen peroxide. **CAS** 13569-57-8.

ISOAMYL p-METHOXYCINNAMATE

I-009	$C_{15}H_{20}O_3$	248.40	ICB, SU, EP, EPE, NAC
-------	-------------------	--------	--------------------------

A UV-B adsorbing agent in sunscreen cosmetics of the type creams, lotions, lipsticks, sun oils, waterproof sunscreens products etc. Trade name is Neo Heliopan E1000. **CAS** 71617-10-2.

Art. No.	Formula	FW	Series
----------	---------	----	--------

Isobornyl Acrylate

I-019	$C_{13}H_{20}O_2$	208.30	MA, MP
-------	-------------------	--------	--------

Isobornyl acrylate is a chemical used in plastics, it polymerizes when exposed to free radicals to form monomers. It can be found in adhesives, sealants, intermediates, photosensitive chemicals, pigments (ink, toner and colorant products), paints, coatings, agricultural products (non-pesticidal) as well as in glucose monitoring systems, such as the FreeStyle® Libre. Also known as IBOA. **CAS** 5888-33-5.

ISOEUGENOL

I-002	$C_{10}H_{12}O_2$	164.21	B, F
-------	-------------------	--------	------

A fragrance used in perfumery, over-the-counter medicines, dental materials and foods. Also used in the production of Vanillin flavor. Found in oils of nutmeg, ylang-ylang etc. Also available as part of Mx-07. **Cross:** EUGENOL. **CAS** 97-54-1.

α -Isomethyl ionone

I-017	$C_{14}H_{22}O$	206.32	F
-------	-----------------	--------	---

α -Isomethyl ionone is used in many floral fragrances, particularly violet. Blends with and supports woody, leathery and oriental accords. **CAS** 127-51-5.

Isophorone diamine

I-006	$C_{10}H_{22}N_2$	170.29	E, I
-------	-------------------	--------	------

A common hardener for epoxy resins. Also a degradation product from Isophorone diisocyanate. Also known as IPD. **CAS** 2855-13-2.

ISOPHORONE DIISOCYANATE

I-007	$C_{12}H_{18}N_2O_2$	222.28	I
-------	----------------------	--------	---

Used in the manufacture of polyurethane plastics and lacquers. Also known as IPDI. **Cross:** Isophorone diamine. **CAS** 4098-71-9.

Art. No.	Formula	FW	Series
----------	---------	----	--------

ISOPROPYL MYRISTATE

I-003	$C_{17}H_{34}O_2$	270.44	ICB, C, NAC
-------	-------------------	--------	-------------

An emollient found in cosmetic and pharmaceutical bases. Has solvent properties. **CAS** 110-27-0.

N-Isopropyl-N-phenyl-4-phenylenediamine

I-004	$C_{15}H_{18}N_2$	226.32	S, IS, R, SH, ECB, LA
-------	-------------------	--------	-----------------------

An antidegradant in natural rubber, styrene-butadiene, nitrile-butadiene, butadiene and chloroprene rubber. Also known as IPPD. Also available as part of Mx-04. **CAS** 101-72-4

J

Jasmine synthetic

J-001			F
-------	--	--	---

Synthetic jasmine for use as fragrance in perfumery. **Cross:** benzylsalicylate.

Jasmine absolute

J-002			F
-------	--	--	---

Natural jasmine for use as fragrance in perfumery. The raw material for this product is made from an hexane extraction of the *Jasminum Grandiflorum* giving a concrete, then the absolute is obtained by extracting the concrete with ethanol. Contains among other substances Benzylbenzoate, Phytol, Isophytol, Linalool, Eugenol, Benzylalcohol, Benzyl salicylate. **Cross:** benzylsalicylate. **May produce hyperpigmentation.** **CAS** 84776-64-7.

Juniperus oxycedrus extract

Tar obtained from distillation of *Juniperus oxycedrus* for use in, e.g., eczema and psoriatic medications and perfumes. Also known as Juniper tar. Available as part of Mx-14. **CAS** 8013-10-3.

Art. No.	Formula	FW	Series
----------	---------	----	--------

K

Kanamycin sulfate

K-001	$C_{18}H_{36-37}N_{4-5}O_{10-11}H_2SO_4$		ME
-------	--	--	----

An antibacterial agent similar to neomycin. **Cross:** neomycin, streptomycin, gentamicin sulfate, dihydrostreptomycin. **CAS** 25389-94-0.

Ketoprofen

K-002B	$C_{16}H_{14}O_3$	254.28	CAD, EP, EPE
--------	-------------------	--------	--------------

Ketoprofen, (RS)2-(3-benzoylphenyl)-propionic acid, is one of the propionic acid NSAIDs with analgesic and antipyretic effects. **CAS** 22071-15-4.

L

LANOLIN ALCOHOL

W-001			S, IS, ECB, LA
-------	--	--	----------------

Different types of alcohols (aliphatic, steroid, triterpenoid) present in wool fat (lanolin). Used as ointment base in cosmetic and pharmaceutical products. Also known as Wool alcohols. **Cross:** eucerin, lanette wax. **CAS** 8027-33-6.

Lamotrigine

L-009	$C_9H_7Cl_2N_5$	256.09	CAD
-------	-----------------	--------	-----

This substance is an anticonvulsant drug used in the treatment of epilepsy and bipolar disorder. It is believed to work in adjunct with other drugs when treating clinical depression. It is used in slow-releasing tablets to prevent episodes of seizures. **CAS** 84057-84-1

Art. No.	Formula	FW	Series
----------	---------	----	--------

LAURYL POLYGLUCOSE

L-004			C, H, ECB
-------	--	--	-----------

A C_{10} - C_{16} non-ionic surfactant with good dermatological compatibility and viscosity enhancing effects. Therefore it is suitable for use as an additive or a co-surfactant in cosmetic surfactant cleansing preparations in e.g. shampoos. Also known as Lauryl glycoside, PLANTACARE® 1200 and D-Glucopyranoside. **CAS** 110615-47-9.

LAVANDULA ANGUSTIFOLIA OIL

Change of name as of January 2016; please refer to Lavender absolute (Art. No. L-001).

Lavender absolute

L-001			F, AC
-------	--	--	-------

A fragrance used in various perfumes. Also used as flavor and carminative. The raw material for this product is made from the freshly cut flowering tops of Lavendula Angustifolia, these are extracted with hexane giving a concrete, then the absolute is obtained by extracting the concrete with ethanol. Also known as LAVANDULA ANGUSTIFOLIA OIL. **Cross:** Geranial. **CAS** 8000-28-0.

Lead(II)acetate trihydrate

Deleted 2019	$Pb(C_2H_3O_2)_2 \cdot 3H_2O$	379.33	
--------------	-------------------------------	--------	--

This hapten is a marker for contact allergy to lead. A white crystalline substance used as a reagent to make other lead compounds and as a fixative for some dyes. In low concentrations, it is the principal active ingredient in progressive types of hair coloring dyes. Lead(II) acetate is also used as a mordant in textile printing and dyeing, as a drier in paints and varnishes. **CAS** 6080-56-4.

Lead(II)chloride

L-008	$PbCl_2$	278.10	MET
-------	----------	--------	-----

This hapten is a marker for contact allergy to lead. Occurs naturally in the form of the mineral cotunnite. It is used in production of infrared transmitting glass and of ornamental glass called aurene glass. A basic chloride of lead, $PbCl_2 \cdot Pb(OH)_2$, is known as Patteson's white lead and is used as pigment in white paint. **CAS** 7758-95-4.

Art. No.	Formula	FW	Series
Lidocaine			
L-002	C ₁₄ H ₂₂ N ₂ O	234.33	ICB, ME, NAE, NAC, AC

Used as a local anesthetic and as antiarrhythmic agent. Also available as part of Mx-13 and Mx-20. **CAS** 137-58-6.

d-Limonene

L-006	C ₁₀ H ₁₆	136.24	F
-------	---------------------------------	--------	---

Limonene is a hydrocarbon, classified as a cyclic terpene. It is a colourless liquid at room temperatures with an extremely strong smell of oranges. It takes its name from the lemon, as the rind of the lemon, like other citrus fruits, contains considerable amounts of this chemical compound, which is responsible for much of their smell. Limonene is a chiral molecule, and as is common with such forms, biological sources produce one enantiomer: the principal industrial source, citrus fruit, contains d-limonene ((+)-limonene), which is the R-enantiomer. Racemic limonene is known as dipentene. **CAS** 5989-27-5.

LINALOOL

L-005	C ₁₀ H ₁₈ O	154.25	F
-------	-----------------------------------	--------	---

Linalool is a naturally-occurring terpene alcohol chemical found in many flowers and spice plants with many commercial applications, the majority of which are based on its pleasant scent (floral, with a touch of spiciness). It is a main constituent of oils of rosewood, Ho, lavender, lavandin, clary sage, bergamot, petitgrain; minor of neroli, tangerine and jasmine. It has other names such as Linalool synthetic, β-linalool, linalyl alcohol, linalyl oxide, p-linalool, allo-ocimenol, 2,6-dimethyl-2,7-octadien-6-ol and linalool synthetic. **CAS** 78-70-6.

Lylral

Change of name as of January 2015; please refer to HYDROXYISOHEXYL 3-CYCLOHEXENE CARBOXALDEHYDE (Art. No. L-003).

Art. No.	Formula	FW	Series
M			
Majanthole			
M-033	C ₁₂ H ₁₈ O	178.27	F

Majantol has a fresh and intensely floral note. The recommended use level of this colorless liquid-to-crystalline product is 5–20%. This ingredient can be used in lily of valley and fruity floral fragrances for detergent powder, fabric softener and soap applications. Also known as 2,2-dimethyl-3-(3-methylphenyl)propan-1-ol. **CAS** 103694-68-4.

MANGANESE CHLORIDE

M-031	Cl ₂ Mn	125.84	MET
-------	--------------------	--------	-----

This hapten is a marker for contact allergy to **manganese**. This chemical is used as a catalyst in the chlorination of organic compounds, in animal feed, and in dry-cell batteries. Metallic manganese is used primarily in steel production to improve hardness, stiffness, and strength. It is also used in carbon steel, stainless steel, and high-temperature steel, along with cast iron and superalloys. **CAS** 7773-01-5.

Melamine formaldehyde

M-001	C ₆ H ₁₂ N ₆ O ₃	216.20	TF
-------	--	--------	----

A textile resin of formaldehyde releasing type for the treatment of draperies, collars, apparel, etc. Also known as Kaurit M70. Also available as part of Mx-16.

MENTHA PIPERITA OIL

Change of name as of January 2016; please refer to Peppermint oil (Art. No. P-036).

MENTHOL

M-002	C ₁₀ H ₂₀ O	156.26	B
-------	-----------------------------------	--------	---

Found in confectionery, perfumery, cough drops, cigarettes, liqueurs, etc. Also used as a topical antipruritic, local anesthetic, gastric sedative. **ICU. CAS** 89-78-1.

Art. No.	Formula	FW	Series
2-Mercaptobenzothiazole M-003	$C_7H_5NS_2$	167.25	S, ICB, O, R, LA SH, ECB, NAE, NAC, AC

An accelerator, retarder, and peptizer for natural and other rubber products such as shoes, gloves, rubber in undergarments and clothing, condoms and diaphragms, medical devices, toys, tires and tubes, renal dialysis equipment, swimwear. Can also be used as a fungicide and works as a corrosion inhibitor in soluble cutting oils and antifreeze mixtures. Also used in greases, adhesives, photographic film emulsions, detergents, veterinary products such as tick and flea powders and sprays. Also known as MBT. Also available as part of Mx-05A, Mx-05B. **CAS** 149-30-4.

Mercury(II)chloride

M-004	$HgCl_2$	271.50	MET
-------	----------	--------	-----

This hapten is a marker for contact allergy to **mercury**. Used in tanning leather and an intensifier in photography. Can also be used as a topical antiseptic and disinfectant. **Cross: other mercurials. CAS** 7487-94-7.

Mercury

M-005	Hg	200.59	DS, DMP, DMS, MET
-------	----	--------	----------------------

Is a chemical reagent and can be found in thermometers and dental amalgams. But also in pharmaceuticals, antifouling paints, agricultural chemicals. **May cause airborne contact dermatitis. CAS** 7439-97-6.

Mercury(II)amidochloride

M-022	$(HgNH_2)Cl$	252.07	MET
-------	--------------	--------	-----

This hapten is a marker for contact allergy to **mercury**. Inorganic mercurial compound used in creams as a topical antiinfective agent (formerly used in the treatment of psoriasis and in skin-lightening formulations). **May cause pigmentation and depigmentation. CAS** 10124-48-8.

Mercury ammonium chloride

Change of name as of January 2014; please refer to Mercury(II) amidochloride (Art. No. M-022).

Art. No.	Formula	FW	Series
2,2-bis(4-(2-Methacryl-oxyethoxy)phenyl)propane M-006	$C_{27}H_{32}O_6$	452.55	DS, MP, DMP

A methacrylic monomer based on bisphenol A. Used in dental restorative composite materials and as a reactive monomer in adhesive products. Also known as BIS-EMA. **CAS** 24448-20-2.

METHENAMINE

H-003	$C_6H_{12}N_4$	140.19	C, E, R
-------	----------------	--------	---------

Used as an urinary antiseptic agent but also as a rubber accelerator and formaldehyde liberator. Used in the production of phenol-formaldehyde resins and can be found as a preservative in cosmetic products. Other uses include epoxy curing agent and corrosion inhibitor for steel. Also known as Hexamine and Hexamethylenetetramine. **May cause airborne contact dermatitis. CAS** 100-97-0.

2-Methoxy-6-n-pentyl-4-benzoquinone

M-008	$C_{12}H_{16}O_3$	208.26	LA, PL
-------	-------------------	--------	--------

The primary hapten of the plant *Primula Obconica* found in glandular hairs on the leaves and the stem. Also known as Primin. **May cause airborne contact dermatitis from contact with Primula. CAS** 15121-94-5.

p-METHYLAMINOPHENOL

M-040	C_7H_9NO	123.15	H
-------	------------	--------	---

The free form of this chemical is known to be present in many hair dyes, as well as in photographic developing and dyeing of furs. **CAS** 150-75-4.

p-METHYLAMINOPHENOL SULFATE

Deleted 2018

METHYL ANTHRANILATE

M-028		151.16	F
-------	--	--------	---

Used in a wide variety of fragrances and flavors. Used as perfume in ointments and in the manufacture of synthetic perfumes; flavorings. Odor Description: orange-flower, fruity, grape-like odor. Some perfumery uses: cherry, banana, strawberry, blueberry, grape. Natural occurrences: grape, concord. Also known as Methyl anthranilate. **CAS** 134-20-3.

Art. No.	Formula	FW	Series
4-METHYLBENZYLIDENE CAMPHOR			
M-024	C ₁₈ H ₂₂ O	254.37	SU, EP, EPE

A UV-B absorbing agent in sunscreen cosmetics of the type creams, lotions, lipsticks, sun oils, etc. Also known as Eusolex 6300. **CAS** 36861-47-9.

6-METHYL COUMARIN			
M-010	C ₁₀ H ₈ O ₂	160.17	

A Synthetic fragrance found in cosmetics, toiletries and soaps. **Cross (photo): 7-methylcoumarin, COUMARIN, 7-methoxycoumarin. PA. CAS** 92-48-8.

METHYLDIBROMO GLUTARONITRILE			
D-049	C ₆ H ₆ Br ₂ N ₂	265.94	S, ICB, C, O, IS, ECB, NA, AC, NAE, NAC, LA

A preservative for metalworking fluids, cosmetics, adhesives, latex emulsions and paints, dispersed pigments and detergents. Active ingredient in Euxyl K 400 and Tektamer 38. Also known as 1,2-Dibromo-2,4-dicyanobutane and MDBGN. **CAS** 35691-65-7.

N,N-Methylene-bisacrylamide			
M-023	C ₇ H ₁₀ N ₂ O ₂	154.17	MP

An acrylamide compound cross-reacting with unidentified primary sensitizers in NAPP and Nyloprint UV-cured printing plates. **CAS** 110-26-9.

Methylene bis-benzotriazolyl tetramethylbutylphenol

Deleted 2018

Methylene bis-benzotriazolyl tetramethylbutylphenol			
M-037	C ₄₁ H ₅₀ N ₆ O ₂	658.86	SU, EP, EPE

UV absorbing agent present in sunscreens as a UV-A and UV-B filter. Main component in Tinosorb M (see M-032). This hapten does not contain DECYL GLUCOSIDE. **CAS** 103597-45-1

Art. No.	Formula	FW	Series
α-Methylene-γ-butyrolactone			
M-026	C ₅ H ₆ O ₂	98.10	PL

Tulipaline A, hapten in the Liliaceae family of plants to which species such as Tulip, Alstromeria Erythronium dens canis & americanum belong. **CAS** 547-65-9.

Methylhydroquinone			
M-025	C ₇ H ₈ O ₂	124.14	DS

A stabilizer and antioxidant in acrylic monomers to prevent polymerization. **CAS** 95-71-6.

METHYLISOTHIAZOLINONE			
M-035	C ₄ H ₅ NOS	115.15	S, ICB, C, IS, ECB, NA, NAE, NAC, LA, AC

A component in Kathon CG which is used as preservative for use in cosmetics, shampoos, cooling fluids, detergents etc. Also present as a component in Art. No. C-009 (see this compound for further information). Also known as MI. **CAS** 2682-20-4.

METHYLISOTHIAZOLINONE + METHYLCHLOROISOTHIAZOLINONE			
C-009	C ₄ H ₄ CINOS	149.60	S, ICB, C, H, LA O, SH, IS, ECB, AC, NA, NAE, NAC

This product, a component in biocides, is used as a preservative in oil and cooling fluids, soaps, latex emulsions, slime control in paper mills, jet fuels, milk sampling, radiography, printing inks, moist toilet paper, detergents, shampoos, hair conditioners, hair & body gels, bubble baths, skin creams & lotions, mascaras, etc. The following biocides contain METHYLISOTHIAZOLINONE + METHYLCHLOROISOTHIAZOLINONE: Acticide, Algucid CH 50, Amerstat 250, Euxyl K 100, Fennosan IT 21, GR 856 Izolin, Grotan TK2, Kathon CG, Kathon 886MW, Kathon LX, Kathon WT, Mergal K7, Metatin GT, Mitco CC 31 L, Mitco CC 32 L, Special Mx 323, Parmetol DF 35,-DF 12, -A23,-K50,-K40,-DF 18, P3 Multan D, Piror P109. Also known as ProClin 150, MI/MCI. METHYLISOTHIAZOLINONE is also available separately as Art. No. M-035 **May cause airborne contact dermatitis. CAS** 55965-84-9.

Art. No.	Formula	FW	Series
Methyl methacrylate M-013	$C_5H_8O_2$	100.12	ICB, DS, MA, DMP, DMS, MP AC, NA, NAE, NAC

A methacrylic monomer in plastics for dentures, bone cement, artificial nails, hearing aids etc. Also known as MMA. **CAS** 80-62-6.

Methyl-2-octynoate M-034	$C_9H_{14}O_2$	154.21	F
------------------------------------	----------------	--------	---

Methyl-2-octynoate is one of many ingredients in fragrances. It's end applications include soap, detergents, beauty care products, household products. **CAS** 111-12-6.

N-Methylolchloroacetamide M-014	$C_3H_6ClNO_2$	123.54	O
---	----------------	--------	---

A preservative in cooling fluids and cosmetics. Also known as Grotan HD II and Parmetol K 50. **May cause airborne contact dermatitis.** **CAS** 2832-19-1.

METHYL PARABEN Deleted 2021	$C_8H_8O_3$	152.15	
---------------------------------------	-------------	--------	--

A preservative in foods (salad dressings, mayonnaise, spiced sauces, mustard, frozen dairy products, baked products), cosmetics and pharmaceutical preparations. Also known as Methyl-4-hydroxybenzoate and Nipagin. Cross: other parabens, hydroquinonemonobenzylether, para group of compounds. Also available as part of Mx-03A, Mx-03C. **ICU. NICU. CAS** 99-76-3.

Methylprednisolone aceponate M-036	$C_{27}H_{36}O_7$	472.58	CS
--	-------------------	--------	----

A topical corticosteroid used for treating eczema and psoriasis, it suppresses inflammatory and allergic skin reactions and thus relaxes symptoms originating from the skin problem like redness (erythema), thickening of the skin, coarseness of the skin surface, fluid build-up (edema), itchiness, and other complaints (burning sensation or pain). Due to its high lipophilicity and the fact that it is bioactivated in the skin, enables single daily application without any loss of efficacy. Also known as Advantan. **CAS** 86401-95-8

Art. No.	Formula	FW	Series
2-METHYLRESORCINOL M-039	$CH_3C_6H_3(OH)_2$	124.14	H

This substance is typically used in the formulation of hair dyes and colors. **CAS** 608-25-3.

Miconazole M-027	$C_{18}H_{14}Cl_4N_2O$	416.12	ME
----------------------------	------------------------	--------	----

An antifungal agent of the imidazole type which is used in topical and vaginal preparations to prevent growth of dermatophytes, yeast and molds. **Cross: econazole, enilconazole. CAS** 22916-47-8.

Minocycline hydrochloride Deleted 2019	$C_{23}H_{27}N_3O_7 \cdot HCl$	493.94	
--	--------------------------------	--------	--

Minocycline hydrochloride, also known as minocycline, is a member of the broad spectrum tetracycline antibiotics, and has a broader spectrum than the other members. It is a bacteriostatic antibiotic. **CAS** 13614-98-7.

Molybdenum M-030	Mo	95.94	MET
----------------------------	----	-------	-----

This metal is often used in high-strength steel alloys. It is found in trace amounts in plants and animals, although excess molybdenum can be toxic in some animals. The ability of molybdenum to withstand extreme temperatures without significantly expanding or softening make it useful in applications that involve intense heat, including aircraft parts, electrical contacts, industrial motors, and filaments. Molybdenum is also used in alloys, such as dental alloys for its high corrosion resistance and weldability. Most high-strength steel alloys are 0.25% to 8% molybdenum. **CAS** 7439-98-7.

Art. No.	Formula	FW	Series
Molybdenum(V)chloride			
M-038	MoCl ₅	273.21	MET

This hapten is a marker for contact allergy to **molybdenum**. This chemical is an inorganic compound, a dark volatile solid which is mainly used in research to prepare other molybdenum compounds. For testing purpose this is also used to test allergy for Molybdenum. Molybdenum compounds are found in the manufacture of aircraft parts, electrical contacts, motors, filaments, and high-strength steel alloys. It can also be found in dental implants. **CAS** 10241-05-1.

2-Monomethylol phenol

M-015	C ₇ H ₈ O ₂	124.14	PG
-------	--	--------	----

An intermediate in the production of phenol formaldehyde resins which may remain after condensation of the resin. Sensitizer in phenol formaldehyde resins. Also used in local anesthetic. Also known as Saligenin. **CAS** 90-01-7.

2-(4-Morpholinylmercapto)benzothiazol (MOR)

M-016	C ₁₁ H ₁₂ N ₂ OS ₂	252.47	R
-------	--	--------	---

An accelerator for natural rubber, isoprene butadiene, styrene-butadiene, nitrilebutadiene rubber products. Also available as part of Mx-05A, Mx-05B. **CAS** 102-77-2.

MUSK KETONE

Deleted 2021	C ₁₄ H ₁₈ N ₂ O ₅	294.30	
--------------	---	--------	--

A synthetic nitro musk compound used as fragrance and fixative in after shave lotions, perfumes etc. Also available as part of Mx-10B. **CAS** 81-14-1.

Musk moskene

M-019	C ₁₄ H ₁₈ N ₂ O ₄	280.33	F
-------	---	--------	---

A synthetic nitro musk compound used as fragrance and fixative in after shave lotions, perfumes etc. Also available as part of Mx-10B. **CAS** 116-66-5.

Art. No.	Formula	FW	Series
Musk xylene			
M-021	C ₁₂ H ₁₅ N ₃ O ₆	297.45	F

A synthetic nitro musk compound used as fragrance and fixative in after shave lotions, perfumes etc. The musk compound of choice for soap and detergent fragrances. Also available as part of Mx-10B. **Cross (photo): musk ambrette. PA. CAS** 81-15-2.

MYROXYLON PEREIRAE RESIN

Change of name as of January 2016; please refer to Peru balsam (Art. No. B-001).

N

Narcissus poeticus absolute

N-006			F
-------	--	--	---

A fragrance used in various perfumed products. The raw material for this product is made from an solvent extraction of the flowers of Narcissus poeticus. Also known as Narcissus absolute. **CAS** 90064-26-9.

Neomycin sulfate

N-001	C ₂₃ H ₄₆ N ₆ O ₁₃ ·H ₂ SO ₄	712.72	S, ICB, IS, ECB, NA, NAE, NAC, LA, AC
-------	--	--------	---------------------------------------

A broad-spectrum antibiotic found in topical creams, powders, ointments, eye and ear drops. Also used as systemic antibiotic and growth promotor in veterinary use. **Cross: streptomycin, gentamycin, framycetin, dihydrostreptomycin, kanamycin, spectinomycin, tobramycin, paromomycin, butirosin, bacitracin. UCU. CAS** 1405-10-3.

Art. No.	Formula	FW	Series
Nickel(II)sulfate hexahydrate			S, ICB, IS, DS, H, SH, DMP, ECB, NA, NAE, NAC, LA, AC
N-002	NiO ₄ S6H ₂ O	262.86	

Nickel metal: a common hapten present in various alloys, electroplated metal, earrings, watches, buttons, zippers, rings, utensils, tools, instruments, batteries, machinery parts, working solutions of metal cutting fluids, nickel plating for alloys, coins, pigments, dentures, orthopedic plates, keys, scissors, razors, spectacle frames, kitchenware etc. **May produce erythema multiforme like eruptions. May cause airborne contact dermatitis. ICU. CAS 10101-97-0.**

Niobium(V)chloride

N-008	NbCl ₅	270.17	MET
-------	-------------------	--------	-----

In patch testing this chemical is used to diagnose contact allergy to Niobium. Niobium is a metal which can be found in steel, alloys, magnets and electro ceramics. The metal can also be found in medical devices such as pacemakers or joint replacements. It is also used in jewelry. **CAS 10026-12-7.**

4-(2-Nitrobutyl)morpholine

Comp. in E-014	C ₈ H ₁₆ N ₂ O ₃	188.23	O
----------------	--	--------	---

A preservative used in cooling fluids, crude oil, diesel fuel, heating oil etc. 4-(2-Nitrobutyl)morpholine is present in Bioban P 1487 by 70%. Bioban P 1487 also contains 4,4-(2-Ethyl-2-nitrotrimethylene) dimorpholine. Neither of the substances can be ordered separately. **CAS 2224-44-4.**

Nitrofurazone

N-005	C ₆ H ₆ N ₄ O ₄	198.14	ME, LU
-------	---	--------	--------

A topical antibiotic used in human and veterinary medicine and is sometimes also added to animal feeds. Also known as Furacin. **May cause airborne contact dermatitis. CAS 59-87-0.**

Art. No.	Formula	FW	Series
2-NITRO-p-PHENYLENE-DIAMINE			
N-004	C ₆ H ₇ N ₃ O ₂	153.14	H

A dye present in different hair dyeing preparations. These are of the semipermanent type and do not require the use of HYDROGEN PEROXIDE. Also known as 2-Nitro-4-phenylenediamine. **CAS 5307-14-2.**

Norfloxacin

N-007	C ₁₆ H ₁₈ FN ₃ O ₃	319.33	CAD
-------	--	--------	-----

An oral broad-spectrum fluoroquinolone antibacterial agent used in the treatment of urinary tract infections. The mechanism of action of norfloxacin involves inhibition of the A subunit of bacterial DNA gyrase, an enzyme which is essential for DNA replication. Also known as 1-ethyl-6-fluoro-4-oxo-7-piperazin-1-yl-1H-quinoline-3-carboxylic acid. **CAS 70458-96-7.**

O

Oakmoss absolute

O-001			F
-------	--	--	---

An extract of oak moss for use as fragrance in many perfume mixtures, after-shave lotions etc. The raw material for this product is made from an hexane extraction of the moss giving a concrete, then the absolute is obtained by extracting the concrete with ethanol. The moss used is Evernia Prunastri. Also known as tree moss. Contains atranorin, evernic acid and usnic acid. Also available as part of Mx-07. **NOTE: The preparation is based on the raw material of oakmoss absolute that has NOT been subject to chemical reduction of atranol and chloroatranol. PA. CAS 9000-50-4.**

OCTOCRYLENE

O-009	C ₂₄ H ₂₇ NO ₂	361.48	SU, SF, EP, EPE
-------	---	--------	-----------------

An UV-B adsorbing agent in sunscreen cosmetics of the type creams, lotions, lipsticks, sun oils, etc. Also known as 2-ethylhexyl 2-cyano-3,3-diphenylacrylate. Trade name is Eusolex OCR. **CAS 6197-30-4.**

Art. No.	Formula	FW	Series
Octyl gallate			
O-002	C ₁₅ H ₂₂ O ₅	282.34	B, C

An antioxidant for use in cosmetic and pharmaceutical products and in food products such as margarine and peanut butter. Also available as part of Mx-28B. **May cause airborne contact dermatitis. CAS** 1034-01-1.

2-n-Octyl-4-isothiazolin-3-one

O-004	C ₁₁ H ₁₉ NOS	213.34	ICB, O, PG, SH, ECB, NAC
-------	-------------------------------------	--------	--------------------------

A fungicide used in paints, cutting oils, wallpaper adhesives, etc. Also used for the preservation of leather. Also known as Skane M-8, Kathon 893. **CAS** 26530-20-1.

Olaquinox

O-008	C ₁₂ H ₁₃ N ₃ O ₄	263.25	EPE
-------	---	--------	-----

A widespread growth promotor in pig breeding acting as a chemotherapeutic agent prophylactically used to lower the frequency of bacterial enteritis in pigs. Also known as N-(2-Hydroxyethyl)-3-methyl-2-quinoxalinecarboxamide-1,4-dioxide and Bayo-n-ox. **May casue airborne photodermatitis. PA. PL. PT. CAS** 23696-28-8.

OLEAMIDOPROPYL DIMETHYLAMINE

O-005	C ₂₃ H ₄₆ N ₂ O	366.25	ICB, C, O, NA NAE, NAC, AC
-------	--	--------	----------------------------

A cationic emulsifier used in cosmetics such as body lotions, creams, shampoos, hair rinse preparations, etc. **CAS** 109-28-4.

Oligotriacrylate (OTA 480)

Deleted 2021		480	
--------------	--	-----	--

A multifunctional acrylic monomer used in lithographic inks, overprinting varnishes, coatings on wood, paper, etc. cured by UV-light. **CAS** 52408-84-1.

OLEA EUROPAEA OIL

Deleted 2017

Art. No.	Formula	FW	Series
P			
PABA			
A-006	C ₇ H ₇ NO ₂	137.14	SU, EP, EPE

A sun screening agent in cosmetics, moisturizers, shampoos, hair care products, nail polish, lipstick, lip balms, oral vitamin supplements. Used in the production of local anesthetics, folic acid and azo dyes. Also known as 4-Aminobenzoic acid. **Cross: para group of compounds. PA. CAS** 150-13-0.

Palladium(II)chloride

P-001	PdCl ₂	177.31	DS, DMP, MET
-------	-------------------	--------	--------------

This hapten is a marker for contact allergy to **palladium**. A chemical catalyst. Can be found in jewelry, dental alloys and electroplating parts of clocks and watches. **CAS** 7647-10-1.

PANTHENOL

P-042		205.254	C, H
-------	--	---------	------

Used as a humectant, emollient and moisturizer. As panthenol easily binds to hair follicles it is commonly used in shampoos and hair conditioners. **CAS** 16485-10-2

Parthenolide

P-029	C ₁₅ H ₂₀ O ₃	248.32	PL
-------	--	--------	----

Sesquiterpene lactone found in Feverfew (Chrysanthemum Parthenium) which is a Compositae plant growing throughout Europe and in southern USA near homes, on roadsides and in uncultivated places. It is also found in several other Compositae plants and Magnoliaceae. Also available as part of Mx-29A and Mx-29B. **CAS** 20554-84-1.

Penicillin G, potassium salt

Deleted 2018

Art. No.	Formula	FW	Series
----------	---------	----	--------

Pentaerythritol triacrylate

P-002	$C_{14}H_{18}O_7$	298.30	MP
-------	-------------------	--------	----

A trifunctional cross-linking acrylic monomer for use in adhesives, coatings, inks, photoresists, castings, etc. cured by UV radiation. **CAS** 3524-68-3.

Peppermint oil

P-036	$C_{10}H_{16}$	136.2	TF
-------	----------------	-------	----

True peppermint oil is steam distilled from the partially dried herb of *Mentha Piperita* which is a hybrid from three other species of *Mentha*, all natives of southern Europe. Uses include antiemetic agent, Autonomic agent, central nervous system agent, gastrointestinal agent, parasympatholytic agent, Pharmaceutic aid, Flavor and Fragrance agent, Essential Oil. Also known as MENTHA PIPERITA OIL, *Mentha x piperita* L, Peppermint oil, Peppermint terpenes and Pfefferminz oel. **CAS** 8006-90-4.

Peru balsam

B-001			S, ICB, DMP, H, IS, ECB, NA, AC NAE, NAC, LA
-------	--	--	--

Found as flavor in tobacco, drinks, pastries, cakes, wines, liquors, spices etc. Used as a fixative and fragrance in perfumery. Also used in topical medicaments, dentistry, etc. Consists of esters of cinnamic and BENZOIC ACID, Vanillin, styracine. Also known as Balsam Peru, MYROXYLON PEREIRAE RESIN, Indian balsam, China oil, Black balsam, Honduras balsam and Surinam balsam. **Cross: COLOPHONIUM, tolu balsam absolute, cinnamates, benzoates, styrax, benzoin, tiger balm, beeswax, benzaldehyde, benzylsalicylate, coniferyl alcohol, COUMARIN, EUGENOL, Isoeugenol, FARNESOL, propanidid, propolis, diethylstilbestrol. May produce erythema-multiforme like eruptions. PT. NICU. CAS** 8007-00-9

PETROLATUM

P-003			
-------	--	--	--

A white petrolatum which is a purified mixture of semisolid hydrocarbons. As ointment base in cosmetics. Leather grease and shoe polish component. Supplier of Chemotechniques petrolatum is Penreco. **May cause hyperpigmentation. CAS** 8009-03-8.

184

Art. No.	Formula	FW	Series
----------	---------	----	--------

Phenol formaldehyde resin (PFR2)

P-005			PG, IS
-------	--	--	--------

A resin based on phenol and formaldehyde which contain methylol phenols. Used in binders, adhesives, laminates, impregnation products, surface coatings, casting sand, etc. Simultaneous contact allergic reactions to Peru balsam and COLOPHONIUM over represented. **May cause airborne contact dermatitis.**

PHENOXYETHANOL

P-025	$C_8H_{10}O_2$	138.16	C, AC
-------	----------------	--------	-------

A fixative for perfumes, used as bactericide in conjunction with METHYLDIBROMO GLUTARONITRILE (Euxyl K 400) as well as quaternary ammonium compounds. Also used as insect repellent and topical antiseptic. **CAS** 122-99-6.

1-Phenyl-3-pyrazolidinone

Deleted 2018

PHENYLBENZIMIDAZOLE SULFONIC ACID

P-024	$C_{13}H_{10}N_2O_3S$	274.30	SU, EPE
-------	-----------------------	--------	---------

A sun-screening agent for use in various sunscreen products. Trade names: Eusolex 232 and Novantisol. Also known as 2-Phenylbenzimidazol-5-sulfonic acid. **CAS** 27503-81-7.

Phenylbutazone

P-041	$C_{19}H_{20}N_2O_2$	308.37	ME
-------	----------------------	--------	----

An anti-inflammatory agent with antipyretic and analgesic activities. It is used in the treatment of ankylosing spondylitis and rheumatoid arthritis. In some countries the drug is only approved for use in veterinary medicine. **CAS** 50-33-9.

Art. No.	Formula	FW	Series
p-PHENYLENEDIAMINE (PPD)			
P-006	C ₆ H ₈ N ₂	108.14	S, ICB, IS, H, SH, ECB, NA, AC, NAE, NAC,

LA

The primary intermediate in permanent hair dyes and fur dyes (valid for p-PHENYLENEDIAMINE (PPD)). Also used in photographic developers, lithography, photocopying, oils, greases, gasoline and as antioxidant/accelerator in the rubber and plastic industry. The hydrochloride is used as blood reagent. **Cross: parabens, PABA, para compounds. May produce erythema multiforme like eruptions. May cause airborne contact dermatitis. PA. UCU. CAS 106-50-3.**

p-PHENYLENEDIAMINE HCL

Deleted 2018

2-Phenyl glycidyl ether

P-023	C ₉ H ₁₀ O ₂	150.18	E
-------	---	--------	---

A reactive diluent in epoxy resin systems. Forms chemical bonds with the resin during cure and accelerates the curing process. **CAS 122-60-1.**

2-Phenylindole

P-007	C ₁₄ H ₁₁ N	193.25	PG
-------	-----------------------------------	--------	----

A stabilizer in PVC-plastic products. Also known as α-phenylindole. **CAS 948-65-2.**

PHENYL MERCURIC ACETATE

P-008	C ₈ H ₈ HgO ₂	336.74	C, LU, MET
-------	--	--------	------------

Used as herbicide and fungicide. As preservative in antibiotic eye drops, eye cosmetics, shampoos, etc. Also known as Advacide PMA 18, Cosan PMA, Mergal A25, Metasol 30, Nildew AC 30, Nuodex PMA 18 and Nylmerate. **Cross: p-chloromercuriphenol. ICU. CAS 62-38-4.**

Art. No.	Formula	FW	Series
N-Phenyl-2-naphtylamine			
P-009	C ₁₆ H ₁₃ N	219.29	R

An antidegradant for various rubber products such as natural rubber, styrene-butadiene, nitrile, butadiene and chloroprene. Also known as phenyl-beta-naphtylamine and PBN. **CAS 135-88-6.**

o-PHENYLPHENOL

P-010	C ₁₂ H ₁₀ O	170.20	O
-------	-----------------------------------	--------	---

A preservative used in cosmetics, cooling fluids, detergents and as agricultural fungicide for citrus fruits, etc. Also known as 2-phenylphenol and Dowicide 1. **Photosensitizer. May cause depigmentation. CAS 90-43-7.**

PHENYL SALICYLATE

P-011	C ₁₃ H ₁₀ O ₃	214.22	C, PG
-------	--	--------	-------

Used as UV-light adsorber in plastics, suntan oils, and creams. Also found in waxes, adhesives, polishes etc. Used as analgesic, antipyretic, and anti-rheumatic agent. Can also be found in veterinary use as external disinfectant and intestinal antiseptic agent. Also known as Salol. **CAS 118-55-8.**

Pine tar

A product obtained by dry-distillation of wood from pine. Consists of turpentine, various phenols, xylene, etc. Topical antieczematic and rubefacient. Also known as PINUS PALUSTRIS TAR. Available as part of Mx-14. **CAS 8011-48-1.**

Piroxicam

P-033	C ₁₅ H ₁₃ N ₃ O ₄ S	331.35	CAD, EP, EPE
-------	---	--------	--------------

Piroxicam (marketed in the U.S. under the trade name Feldene) is a NSAID used to relieve the symptoms of rheumatoid and osteoarthritis, primary dysmenorrhoea, postoperative pain; and act as an analgesic, especially where there is an inflammatory component. It is also used in veterinary medicine to treat certain neoplasias expressing cyclooxygenase (COX) receptors, such as bladder, colon, and prostate cancers. Other brand names for Piroxicam include Brexin, Erazon, Felden, Feldoral, Hotemin, Pirox von ct, Proponol, Reumador, Veral, and Vurdon. **CAS 36322-90-4.**

Art. No.	Formula	FW	Series
----------	---------	----	--------

POLYAMINOPROPYL BIGUANIDE

P-043			C
-------	--	--	---

A preservative found in cosmetics, personal care products, fabric softeners, contact lens solutions, wet wipes and more. Also used as deodorizer and disinfectant. **CAS** 27083-27-8

Polymeric diphenylmethane diisocyanate (PMDI)

P-038			I
-------	--	--	---

Diphenylmethane diisocyanate (MDI), see D-023, is the generic name of a product used in industrial settings. Polymeric MDI (PMDI), the primary technical/commercial form of MDI, is actually a mixture that contains 25–80% monomeric 4,4'-MDI as well as oligomers containing 3–6 rings and other minor isomers, such as the 2,2'-isomer. The exact composition of PMDI varies with the manufacturer. PMDI is used to make rigid and flexible foam, foundry resin sand binders, and heat insulating material.

Polymyxin B Sulfate

P-026	$C_{56}H_{100}N_{16}O_{17}S$	1385.63	ME, AC
-------	------------------------------	---------	--------

An antibacterial peptide produced from *Bacillus polymyxa*. Polymyxin B is commonly found in topical antibiotic ointments and creams. **CAS** 1405-20-5

Polysilicone-15

P-035		> 6000	EPE
-------	--	--------	-----

Is an organic compound used in hair products like shampoos, conditioners, hair sprays, pomades and color treatment products to absorb UVB radiation. In the EU, it is also approved for use in sunscreens and cosmetics. Also known as Parsol SLX. **CAS** 207574-74-1.

Polyethylene glycol 400 (PEG 400)

P-034	$H(OCH_2CH_2)_nOH$	approx. 400	6
-------	--------------------	-------------	---

Polyethylene glycol PEG400 refers to a polymer of ethylene oxide with a molecular mass below 20,000 g/mol, in this case 400. This chemical has many industrial, foods, cosmetic and medical applications. It is added to skin lotions, creams, jellies, soaps and toothpastes. It is the basis for many laxatives and bowel irrigation preparations. It is also

Art. No.	Formula	FW	Series
----------	---------	----	--------

used as a lubricant in tire manufacturing; plasticizer for sponges and synthetic leather; a paper softener; anti-curl agent; and an intermediate in resin manufacturing. **CAS** 25322-68-3

POLYSORBATE 80

P-013			ICB, C, NAC
-------	--	--	-------------

An emulsifier and dispersing agent for medicinal products for internal use. Used as emulsifier in cosmetics, pharmaceuticals & food. Also known as Polyoxyethylenesorbitan monooleate and Tween 80. **CAS** 9005-65-6.

Potassium clavulanate

P-040	$C_8H_8NO_5K$	237.25	CAD
-------	---------------	--------	-----

This chemical is a drug which is given with antibiotics. While not effective by itself as an antibiotic, when combined with penicillin-group antibiotics, it can overcome antibiotic resistance in bacteria that secrete β -lactamase, which otherwise inactivates most penicillin's. **CAS** 61177-45-5.

Potassium dichromate

P-014	$Cr_2K_2O_7$	294.21	S, ICB, DS, P, SH, IS, DMP, ECB, NA, NAE, NAC, LA, AC
-------	--------------	--------	---

This hapten is a marker for contact allergy to **chromium**. The hexavalent form of chromium, which is used in cement, tanning of leather, textile dyes, wood preservatives, alloys in metallurgy, safety matches, photography, electroplating, anticorrosives, engraving and lithography, ceramics, automobile industry, TV manufacturing, photocopy paper, tattoos, mascara/eye shadow pigments (chromium oxide), milk testing, welding, floor waxes, shoe polishes, paints, glues, pigments, detergents, etc. **May cause airborne contact dermatitis.** **CAS** 7778-50-9.

Potassium dicyanoaurate(I)

P-015	C_2AuKN_2	288.13	MET
-------	-------------	--------	-----

This hapten is a marker for contact allergy to **gold**. Gold salt used in the electroplating industry. **CAS** 13967-50-5.

Art. No.	Formula	FW	Series
----------	---------	----	--------

Pramoxine hydrochloride

P-039	$C_{17}H_{27}NO_3 \cdot HCl$	329.86	ME
-------	------------------------------	--------	----

This substance is a topical anesthetic and used as an antipruritic. Like other local anesthetics, the drug decreases the permeability of neuronal membranes to sodium ions, blocking both initiation and conduction of nerve impulses. Depolarization and repolarization of excitable neural membranes is thus inhibited, leading to numbness. **CAS** 637-58-1.

Prilocaine hydrochloride

P-027	$C_{13}H_{21}ClN_2O$	256.8	
-------	----------------------	-------	--

Used as a local anesthetic agent. Also known as Citanest, Xylonest. Also available as part of Mx-20. **CAS** 1786-81-8.

Pristinamycin

Deleted 2021

Pristinamycin is an antibiotic used primarily in the treatment of staphylococcal infections, and to a lesser extent streptococcal infections. It is a streptogramin group antibiotic, similar to virginiamycin, derived from the bacterium *Streptomyces pristina spiralis*. It is marketed in Europe by Sanofi-Aventis under the trade name Pyostacine. Pristinamycin is a mixture of two components that have a synergistic antibacterial action. Pristinamycin I is a macrolide, and results in pristinamycin having a similar spectrum of action to erythromycin. Pristinamycin II is a depsipeptide. **CAS** 11006-76-1.

Procaine hydrochloride

P-016	$C_{13}H_{21}ClN_2O_2$	272.77	
-------	------------------------	--------	--

A local anesthetic agent also known as Novocaine, Ethocaine, Allocaine, Topocaine, Neocaine and Syncaïne etc. **Cross: para group of compounds, parabens, butethamine, PABA.** **CAS** 51-05-8.

Promethazine hydrochloride

P-017	$C_{17}H_{21}ClN_2S$	320.87	EP, EPE
-------	----------------------	--------	---------

An antihistaminic, antiemetic, CNS depressant used in pills, syrup, injections and suppositories. Also known as Phenergan, Lergigan, Atosil, Fenazil etc. **Cross: phenothiazines, ethylenediamine-HCl, para compounds, chlorpromazine HCl, tripeleminamine.** May produce erythema multiforme like eruptions. **PA. UCU. PL.** **CAS** 58-33-3.

190

Art. No.	Formula	FW	Series
----------	---------	----	--------

PROPIONIC ACID

P-018	$C_3H_6O_2$	74.08	B
-------	-------------	-------	---

Used as food additive for the preservation against moulds in, e.g., cheese products. Also in the production of fruit flavors and perfume bases. **CAS** 79-09-4.

Propolis

P-022			ECB, ICB, NA, NAE, AC, NAC, PL, LU, S
-------	--	--	---------------------------------------

A resinous substance found in beehives (beeglu). Collected by bees from treebuds. Found in biocosmetics, face creams, ointments, lotions, solutions, varnish, toothpaste, mouthwashes, tablets, chewing gum, etc. Also found in wax for violins. Contains flavonoid aglycones and the main hapten is 1,1-dimethylallyl caffeic acid ester (LB-1). **Cross: Peru balsam. May cause airborne contact dermatitis.** **CAS** 85665-41-4

PROPYLENE GLYCOL

P-019	$C_3H_8O_2$	76.09	ICB, C, O, LU, AC, NA, NAE, NAC
-------	-------------	-------	---------------------------------

Used as vehicle in pharmaceutical and cosmetic bases. In food it is used as solvent for colors and flavors and to prevent growth of moulds. Works as humectant and can also be found in cooling fluids. **UCU.** **CAS** 57-55-6.

PROPYL GALLATE

P-021	$C_{10}H_{12}O_5$	212.20	B, C, LA
-------	-------------------	--------	----------

An antioxidant in cosmetic and pharmaceutical creams, emulsions, various fats, oils and waxes. Can also be found in foods like margarine, peanut butter, etc. Also available as part of Mx-28B. **CAS** 121-79-9.

PROPYLPARABEN

P-020	$C_{10}H_{12}O_3$	180.20	
-------	-------------------	--------	--

A preservative in foods (salad dressings, mayonnaise, spiced sauces, mustard, frozen dairy products, baked products), cosmetics

Art. No.	Formula	FW	Series
----------	---------	----	--------

and pharmaceutical preparations. Also known as Propyl-4-hydroxybenzoate. Also available as part of Mx-03A, Mx-03C.

Cross: hydroquinone monobenzyl ether, other parabens, para compounds. CAS 94-13-3.

Q

QUATERNIUM-15

C-007	$C_9H_{16}Cl_2N_4$	251.20	ICB, S, IS, C, H, ECB, NA, NAE, NAC, LA, AC
-------	--------------------	--------	---

A formaldehyde-releasing preservative in hand creams, lotions, face creams, shampoos, latex paints, topical medicaments, polishes, metal working fluids, adhesives, inks, etc. Also known as Dowicil 200 and 1-(3-Chloroallyl)-3,5,7-triaza-1-azoniaadamantane chloride. **CAS 51229-78-8.**

Quinine sulfate

Q-001	$(C_{20}H_{24}N_2O_2) \cdot H_2SO_4 \cdot 2H_2O$	746.93	ME
-------	--	--------	----

An antimalarial agent also used as antipyreticum and in liquids (tonic etc.). **PA. CAS 6119-70-6.**

R

Reactive Black 5

R-004	$C_{26}H_{21}N_5Na_4O_{19}S_6$	991.79	TF
-------	--------------------------------	--------	----

An azo dye belonging to the reactive dye class used for coloring cotton, wool, silk and polyamide textiles. **May cause allergic conjunctivitis, allergic rhinitis and occupational asthma. CAS 17095-24-8.**

Reactive Blue 21

Art. No.	Formula	FW	Series
----------	---------	----	--------

R-005			TF
-------	--	--	----

A phthalocyanine-copper complex dye belonging to the reactive dye class used for coloring cotton, wool, silk and polyamide textiles. **May cause allergic conjunctivitis, allergic rhinitis and occupational asthma. CAS 12236-86-1.**

Reactive Orange 107

R-007			TF
-------	--	--	----

An azo dye belonging to the reactive dye class used for coloring cotton, wool, silk and polyamide textiles. **May cause allergic conjunctivitis, allergic rhinitis and occupational asthma. CAS 94158-82-4.**

Reactive Red 123

R-008			TF
-------	--	--	----

An azo dye belonging to the reactive dye class used for coloring cotton, wool, silk and polyamide textiles. **May cause allergic conjunctivitis, allergic rhinitis and occupational asthma.**

Reactive Red 228

R-010			TF
-------	--	--	----

An monoazo dye belonging to the reactive dye class used for coloring cotton, wool, silk and polyamide textiles. **May cause allergic conjunctivitis, allergic rhinitis and occupational asthma.**

Reactive Red 238

Deleted 2018

Reactive Violet 5

R-011			TF
-------	--	--	----

An dye belonging to the reactive dye class used for coloring cotton, wool, silk and polyamide textiles. **May cause allergic conjunctivitis, allergic rhinitis and occupational asthma. CAS 12226-38-9.**

Art. No.	Formula	FW	Series
----------	---------	----	--------

RESORCINOL

R-001	C ₆ H ₆ O ₂	110.11	H
-------	--	--------	---

A keratolytic agent found in acne medications. Used in hair dyes, resins, tanning, cosmetics, Castellanis paint, eye drops, suppositories, photocopying and photographic solutions, explosives, etc. Also used a topical antipruritic and antiseptic agent. **Cross: phenol. May cause orange-brown discoloration of lacquered nails and may darken fair hair. CAS 108-46-3.**

Resorcinol monobenzoate

R-002	C ₁₃ H ₁₀ O ₃	214.22	PG
-------	--	--------	----

An UV-light absorber added mainly to out door plastics. Has caused dermatitis as additive in spectacle frames. **Cross: Peru balsam. CAS 136-36-7.**

Rhodium(III)chloride hydrate

R-013	RhCl ₃ · xH ₂ O		MET
-------	---------------------------------------	--	-----

This hapten is a marker for contact allergy to **rhodium**. This metal can be found in precious metal alloys and in electroplating. In jewelry it can be found in white gold, platinum, and sterling silver. Rhodium is also used as an alloying agent for hardening and improving the resistance of platinum and palladium to corrosion which can be used in coatings. In the car industry rhodium is used as a catalytic converter. **CAS 20765-98-4.**

ROSA DAMASCENA EXTRACT

Change of name as of January 2016; please refer to Rose absolute (Art. No. R-003).

Rose absolute

R-003			F
-------	--	--	---

A fragrance used in various perfumes and for flavoring lozenges, ointments, toilet preparations, etc. The raw material for this product is made from an solvent extraction of the flowers. Contains among other substances Citronellol, Phenyl ethyl alcohol, Geraniol, Nerol,

Art. No.	Formula	FW	Series
----------	---------	----	--------

Eugenol. Also known as ROSA DAMASCENA EXTRACT, Rose oil.

Ruthenium

R-012	Ru	101.07	MET
-------	----	--------	-----

Ruthenium is a chemical element and a rare transition metal, which is inert to most other chemicals. Ruthenium usually occurs as a minor component of platinum ores. Most ruthenium produced is used for wear-resistant electrical contacts and the production of thick-film resistors. A minor application of ruthenium is its use in some platinum alloys, and as a catalyst. It might also be found in dental implants. **CAS 7440-18-8.**

S

Sandalwood oil

S-009			F
-------	--	--	---

A fragrance used in various perfumed products like soap, after-shave lotions, colognes and cosmetics. Also known as. SANTALUM ALBUM OIL. **PA. PT. PL. CAS 8006-87-9.**

SANTALUM ALBUM OIL

Change of name as of January 2016; please refer to Sandalwood oil (Art. No. S-014).

SHELLAC

S-015			C
-------	--	--	---

Shellac is a resin secreted by the female lac bug, on trees in the forests of India and Thailand. It is processed and sold as dry flakes, which are dissolved in denatured alcohol to make liquid shellac, which is used as a brush-on colorant, food glaze and wood finish. Shellac is edible and it is used as a glazing agent on pills and candies in the form of pharmaceutical glaze. When used for this purpose, it has the food additive E number E904. **CAS 9000-59-3.**

Art. No.	Formula	FW	Series
----------	---------	----	--------

SILVER NITRATE

S-007	AgNO ₃	169.89	MET
-------	-------------------	--------	-----

This hapten is a marker for contact allergy to **silver**. Used in photography, silver plating, coloring porcelain, manufacturing of mirrors, etching ivory, analytical reagent. Can also be used as astringent and antiseptic agent. **May cause gray-brown discoloration of the conjunctivae and black discoloration of the fingernails.** CAS 7761-88-8.

SODIUM BENZOATE

S-001	C ₇ H ₅ NaO ₂	144.11	B, AC
-------	--	--------	-------

A preservative especially used for food products (drinks, jams, jellies, pickles, syrups, etc.) Also commonly found in cosmetic and pharmaceutical products. **NICU.** CAS 532-32-1.

SODIUM LAURYL SULFATE

S-018	CH ₃ (CH ₂) ₁₁ OSO ₃ Na	288.38	
-------	--	--------	--

Described in the literature as a substance used as an irritant control in patch testing and works well in terms of reproducibility and a high number of patients are reacting to it. The chemical is an anionic surfactant used in many cleaning and hygiene products. The salt is an organosulfate consisting of a 12-carbon tail attached to a sulfate group, giving the material the amphiphilic properties required of a detergent. Being derived from inexpensive coconut and palm oils, it is a common component of many domestic cleaning products. **CAS** 151-21-3.

SODIUM METABISULFITE

S-011	Na ₂ S ₂ O ₅	190.1	C, H, ECB
-------	---	-------	-----------

Used as a food additive, mainly as a preservative and is sometimes identified as E223. As an additive, it may cause allergic reactions, particularly skin irritation e.g. eczema; gastric irritation and asthma. It is present in many dilutable squashes. It is commonly used in homebrewing preparations to sanitize equipment. It is used as a cleaning agent for potable water reverse osmosis membranes in desalination systems. It is also used to remove chloramine from drinking water after treatment. In the brand Stump-Out, it is used in almost a pure form (98%) to cause degradation of lignin, creating

Art. No.	Formula	FW	Series
----------	---------	----	--------

pores for fuel adsorption, and consequently, ignition. **CAS** 7681-57-4.

Sodium-2-pyridinethiol-1-oxide

S-002	C ₅ H ₄ NOSNa	149.14	C, O
-------	-------------------------------------	--------	------

A bactericide used in cooling fluids and short term -in can- preservation of vinyl acetate latex, paints and synthetic fiber lubricants. Can also be found as a preservative for cosmetic rinse-off products. Also known as Sodium omadine. **CAS** 3811-73-2.

Sodium tetrachloropalladate(II) hydrate

S-017	Cl ₄ Na ₂ Pd3H ₂ O	348.20	DS, DMP, MET, LA
-------	---	--------	------------------

This hapten is a marker for contact allergy to **palladium**. It is an inorganic compound used in among other things in chemical synthesis as a catalyst. It is present in many alloys containing palladium. **CAS** 13820-53-6.

Sodium tungstate dihydrate

S-019	Na ₂ WO ₄ · 2H ₂ O	329.85	MET
-------	---	--------	-----

In patch testing Sodium tungstate dihydrate is used to diagnose a contact allergy to **tungsten**. It can be found in incandescent light bulb filaments, X-ray tubes, and electrodes in welding, superalloys, and radiation shielding. About half is used in the form of tungsten carbide, WC. Tungsten's hardness and high density gives it military applications in penetrating projectiles. Tungsten compounds are also often used as industrial catalysts. In medicine, tungsten can be found in medical devices such as joint replacements, intravascular devices and dental implants. Tungsten is also used in jewelry. **CAS** 10213-10-2.

Softisan 649

S-016			
-------	--	--	--

SOFTISAN 649 is a partial ester of diglycerin with medium chain fatty acids, isostearic acid, stearic acid, 12-hydroxystearic acid and adipic acid. Used in cosmetics in skin care, baby creams, decorative cosmetics and hair care products as lanolin substitute and as a cream base. **CAS** 130905-60-1.

Art. No.	Formula	FW	Series
SORBIC ACID			
S-003	C ₆ H ₈ O ₂	112.13	B, C, LU, AC

A preservative (antifungal) found in foods like cheese syrup etc. and in cosmetic and pharmaceutical products. Also used in alkyd coatings and drying oils, adhesives, glues, inks, paints, varnishes, tanning agents, metalworking fluids. **Cross: potassium sorbate. ICU, NICU. CAS 110-44-1.**

SORBITAN OLEATE			
S-004			C, LU

Monoester of oleic acid and hexitol anhydrides derived from sorbitol. An emulsifier in cosmetic and pharmaceutical ointments and creams. Also known as Sorbitan monooleate and Span 80. **Cross: SORBITAN SESQUIOLEATE. CAS 1338-43-8.**

SORBITAN SESQUIOLEATE			
S-005			C, LU, AC

Mixed ester of oleic acid and hexitol anhydrides derived from sorbitol. Used as emulsifier in cosmetic and pharmaceutical ointments and creams. **CAS 8007-43-0.**

Spiramycin base			
S-012	C ₄₃ H ₇₄ N ₂ O ₁₄	842.51	CAD

Spiramycin is a macrolide antibiotic which is used to treat toxoplasmosis. Although routinely used in Europe, spiramycin is still considered an experimental drug in the United States. Used in Europe since 2000 year as "Rovamycine", produced by Rhone-Poulenc Rorer, France and Eczacibasi Ilae, Turkey. **CAS 8025-81-8.**

STANNOUS CHLORIDE			
S-013	SnCl ₂	189.60	MET

This hapten is a marker for contact allergy to **tin**. A solution of tin(II) chloride containing a little hydrochloric acid is used for the tin-plating of steel, in order to make tin cans. SnCl₂ also reduces quinones to hydroquinones. STANNOUS CHLORIDE is also added as a food additive with E number E512 to some canned and bottled foods, where it serves as a color-retention agent and antioxidant. It is used in production of ornamental glass called aurene glass. **CAS 7772-99-8.**

Art. No.	Formula	FW	Series
Stannous oxalate			

Change of name as of January 2014; please refer to Tin(II)oxalate (Art. No. S-014).

STEARYL ALCOHOL			
S-006	C ₁₈ H ₃₈ O	270.48	C

A lubricant and antifoam agent in cosmetic and pharmaceutical creams and in textile oils and finishes. **UCU. CAS 112-92-5.**

Styrax			
S-008			F

Balsam obtained from the trunk of trees. Contains cinnamates, styrene, etc. Used in perfumery. **Cross: Peru balsam, tincture of benzoin, dieethylstilbestrol. CAS 8046-19-3.**

Sulfanilamide			
S-010	C ₆ H ₈ N ₂ O ₂ S	172.21	ME

A topical and vaginal antibiotic of sulfonamide type. **Cross (photo): para group of compounds. May produce erythema multiforme like eruptions. PA. PL. CAS 63-74-1.**

T

Tanacetum vulgare extract			
T-033			PL

A strongly aromatic weed growing in uncultivated areas, along roadsides, rivers etc. Grows all over Europe and in North America. Used as a herbal remedy, for seasoning and for making a tea. The oil is used as a vermifuge and in perfumery. Contains the sesquiterpene lactones arbusculin-A and tanacetin. Also known as Tanacetum Vulgare and Tansy. Also available as part of Mx-29A and Mx-29B. **Cross: Other plants within the Compositae family.**

Art. No.	Formula	FW	Series
----------	---------	----	--------

Tantalum

T-047	Ta	180.95	MET
-------	----	--------	-----

Tantalum is a chemical element. It is widely used as minor component in alloys. Its main use today is in tantalum capacitors in electronic equipment such as mobile phones, DVD players, video game systems and computers. It can also be used in medical implants and bone repair. **CAS** 7440-25-7.

Taraxacum officinale extract

T-032			PL
-------	--	--	----

Taraxacum Officinale (Dandelion) is a weed that grows in open fields, on prairies, in garbage dumps, etc. and spread all over the world. It is a popular folk medicine plant (laxative, diuretic, tonic, etc.). Haptenic substance is taraxin acid glucoside. Also known as Taraxacum Officinale. **Cross: Other plants within the Compositae family. May cause airborne contact dermatitis.**

Tea tree oil oxidized

T-035			ICB, C, NAE, NAC, AC
-------	--	--	-------------------------

Oil from distilled leaves of Melaleuca Alternifolia. Pale yellowish green oil of a warm spicy aromatic terpenic odor. The oil has served as an antiseptic for many decades but is now also sold as a remedy for various skin and nail conditions. Also present in household products like cleansers, laundry agents and fabric softeners. Some Perfumery Uses: Herbal; Nutmeg; Mint; Pine. Common haptens present are d-limonene, α -terpinene and aromadendrene. **May cause airborne contact dermatitis.**

Tetracaine hydrochloride

T-025	$C_{15}H_{25}ClN_2O_2$	300.83	
-------	------------------------	--------	--

Used as topical and local anesthetic. Amethocaine. Also available as part of Mx-13, Mx-19 and Mx-31. **Cross: Amylocaine hydrochloride. CAS** 136-47-0.

Art. No.	Formula	FW	Series
----------	---------	----	--------

3,3',4',5-Tetrachlorosalicylanilide

Deleted 2018

Tetraethylene glycol dimethacrylate

T-029	$C_{16}H_{26}O_7$	330.37	MA
-------	-------------------	--------	----

A methacrylate present in adhesives and constitutes the main component in polyethylene glycol dimethacrylate in Loctite anaerobic sealants. **CAS** 109-17-1.

Tetraethylthiuram disulfide

T-002	$C_{10}H_{20}N_2S_4$	296.54	R
-------	----------------------	--------	---

An accelerator, activator, stabilizer and vulcanizing agent for various rubber products. Also used as a fungicide, seed disinfectant, and alcohol deterrent. Also known as disulfiram, antabuse and TETD. Also available as part of Mx-01. **CAS** 97-77-8.

Tetrahydrofurfurylmethacrylate

T-027	$C_9H_{14}O_3$	170.21	DS, MA, MN, DMP, DMS
-------	----------------	--------	-------------------------

A methacrylic component used in dental materials such as crown and bridge products. Also used as a component in artificial nails. **CAS** 2455-24-5.

Tetramethylthiuram disulfide

T-005	$C_6H_{12}N_2S_4$	240.44	R
-------	-------------------	--------	---

A rubber accelerator and vulcanizer. Works as a fungicide, disinfectant for seed, bacteriostat in soap, animal repellent, etc. Also known as Thiram and TMTD. Also available as part of Mx-01. **Cross: Tetraethylthiuram monosulfide, Tetraethylthiuram disulfide. CAS** 137-26-8.

Tetramethylthiuram monosulfide

T-006	$C_6H_{12}N_2S_3$	208.37	R
-------	-------------------	--------	---

An accelerator and activator for natural rubber nitrile-butadiene and butyl rubber. Also known as TMTM. Also available as part of Mx-01. **CAS** 97-74-5.

Art. No.	Formula	FW	Series
THIMEROSAL			
T-007	C ₉ H ₉ HgNaO ₂ S	404.84	ICB, C, O, LU, NAC, LA

A preservative used in vaccines, antitoxins, skin testing antigens, antiseptics, eyedrop solutions, contact lens solutions, and cosmetic products like eye makeup. Also known as Merthiolate. **CAS** 54-64-8.

2,2'-THIOBIS(4-CHLOROPHENOL)

F-001	C ₁₂ H ₈ Cl ₂ O ₂ S	287.18	6
-------	---	--------	---

A fungicide especially used against *Monosporium apiospermum*. Used as a topical antifungal and antibacterial agent in hairdressings, antifungal creams, and ointments, also used as thermoplastic resin. **Cross (photo): Bithionol, hexachlorophene. PA. PT. PL. CAS** 97-24-5.

Thiourea

T-026	CH ₄ N ₂ S	76.12	R
-------	----------------------------------	-------	---

A photographic fixing agent and stain remover. Can be used as a rubber accelerator and used in the manufacture of resins. Also used as an antioxidant in photocopy paper to prevent discoloration. **May cause airborne contact dermatitis. PA. CAS** 62-56-6.

Tin

T-008	Sn	118.69	DS, MET
-------	----	--------	---------

A metal used in tin plating, soldering and dental alloys, collapsible tubes. Used in the production of tin salts. **CAS** 7440-31-5.

Tin(II)oxalate

S-014	C ₂ O ₄ Sn	206.71	MET
-------	----------------------------------	--------	-----

This hapten is a marker for contact allergy to **tin**. Tin(II)oxalate is used as a catalyst (Esterification reactions) and in dyeing and printing textiles etc. **CAS** 814-94-8.

Art. No.	Formula	FW	Series
Tioconazole			
T-034	C ₁₆ H ₁₃ Cl ₃ N ₂ OS	387.71	ME

Tioconazole is an antifungal medication of the Imidazole class used to treat infections caused by a fungus or yeast. Tioconazole ointments serve to treat women's vaginal yeast infections. Tioconazole topical (skin) preparations are also available for ringworm, jock itch, athlete's foot, and tinea versicolor or "sun fungus". **CAS** 65899-73-2.

Titanium

T-042	Ti	47.88	MET
-------	----	-------	-----

A light, strong, lustrous, corrosion-resistant (including resistance to sea water and chlorine) transition metal with a grayish color. Can be alloyed with other elements such as iron, aluminium, Vanadium, molybdenum and others, to produce strong lightweight alloys for aerospace, military, industrial process (chemicals and petrochemicals, desalination plants, pulp and paper), automotive, agri-food, medical (prostheses, orthopaedic implants, dental implants), sporting goods, and other applications. **CAS** 7440-32-6.

TITANIUM DIOXIDE

T-040	O ₂ Ti	79.87	MET
-------	-------------------	-------	-----

This hapten is a marker for contact allergy to **titanium**. Is the naturally occurring oxide of Titanium. When used as a pigment, it is called Titanium white or Pigment White 6. It is noteworthy for its wide range of applications, from paint to sunscreen to food colouring. Used as a white food colouring, it has E number E171. In cosmetic and skin care products, TITANIUM DIOXIDE is used both as a pigment and a thickener. It is also used as a tattoo pigment and styptic pencils. This pigment is used extensively in plastics and other applications for its UV resistant properties where it acts as a UV absorber, efficiently transforming destructive UV light energy into heat. **CAS** 13463-67-7.

Titanium(III)nitride

T-039	TiN	61.89	MET
-------	-----	-------	-----

This hapten is a marker for contact allergy to **titanium**. This metal (sometimes known as Tinite) is an extremely hard, ceramic material, often used as a coating on Titanium alloy, steel, carbide, and aluminium components to improve the substrate's surface

Art. No.	Formula	FW	Series

properties. The most common use for TiN coating is for edge retention and corrosion resistance on machine tooling, such as drill bits and milling cutters. Because of TiN's metallic gold color, it is used to coat costume jewelry and automotive trim for decorative purposes. TiN is also widely used as a top-layer coating, usually with nickel or chromium plated substrates, on consumer plumbing fixtures and door hardware. TiN is non-toxic, meets FDA guidelines and has seen use in medical devices and bio-implants, as well as aerospace and military applications. Coatings of TiN have also been used in implanted prostheses and in dental alloys. **CAS** 25583-20-4.

Titanium(IV)oxalate hydrate

Art. No.	Formula	FW	Series
T-041	TiC ₄ O ₉ H ₂ · xH ₂ O	241.92 · xH ₂ O	MET

This hapten is a marker for contact allergy to **titanium**. Titanium oxalate could be used as a source for titanium in a process for preparing zinc-alloy-electroplated steel sheets excellent in corrosion resistance comprising electroplating steel sheets. Used in the preparation of a welding flux binder and welding flux comprising the reaction product of a hydrolyzed and polymerized organometallic compound such as metal esters and metal oxalates. A metal salt for testing of allergy to Titanium in dental alloys.

Tixocortol-21-pivalate

Art. No.	Formula	FW	Series
T-031	C ₂₆ H ₃₈ O ₅ S	462.35	S, ICB, IS, CS, LU, ECB, NA, NAE, NAC, LA

A topical corticosteroid belonging to the group A (hydrocortisone) type of steroids used in nasal sprays for the treatment of rhinitis. Good marker for group A corticosteroid contact allergy. Also available as part of Mx-23. **May cause airborne contact dermatitis.** **Cross: Budesonide, Fluocinolone acetonide, Hydrocortisone, Hydrocortisone-17-butyrate, Prednisolone Acetate, Triamcinolone acetonide.** **CAS** 55560-96-8.

Tobramycin

Art. No.	Formula	FW	Series
T-050	C ₁₈ H ₃₇ N ₅ O ₉	467.51	ME

This substance is an aminoglycoside antibiotic derived from *Streptomyces tenebrarius* and used to treat various types of bacterial infections, particularly Gram-negative infections. **CAS** 32986-56-4.

Art. No.	Formula	FW	Series

TOCOPHEROL

Art. No.	Formula	FW	Series
T-036	C ₂₉ H ₅₀ O ₂	430.71	ICB, C, NAE, NAC, AC

DL-Alpha-tocopherol is the form of vitamin E that is preferentially absorbed and accumulated in humans. In general, food sources with the highest concentrations of vitamin E are vegetable oils, followed by nuts and seeds including whole grains. Although originally extracted from wheat germ oil, most natural vitamin E supplements are now derived from vegetable oils, usually soybean oil. Vitamin E is widely used as an inexpensive antioxidant in cosmetics and foods. Vitamin E containing products are commonly used in the belief that vitamin E is good for the skin; many cosmetics include it, often labeled as tocopherol acetate, tocopheryl linoleate or tocopheryl nicotinate. Some individuals experience allergic reactions to some tocopheryl esters or develop a rash and hives that may spread over the entire body from the use of topical products with alpha tocopheryl esters. **CAS** 10191-41-0.

TOCOPHERYL ACETATE

Art. No.	Formula	FW	Series
T-037	C ₃₁ H ₅₂ O ₃	472.75	C

Tocopheryl acetate, also known as vitamin E acetate, is a common vitamin supplement. It is the ester of acetic acid and tocopherol (vitamin E). It is often used in dermatological products such as skin creams. Tocopheryl acetate is used as an alternative to tocopherol itself because the phenolic hydroxyl group is blocked, providing a less acidic product. It is believed that the acetate is slowly hydrolyzed once it is absorbed into the skin, regenerating tocopherol and providing protection against the sun's ultraviolet rays. **CAS** 7695-91-2.

Tolu balsam absolute

Deleted 2018

TOLUENE-2,5-DIAMINE

Art. No.	Formula	FW	Series
T-049	C ₇ H ₁₀ N ₂	122.17	H

This substance is used in hair dye products. **CAS** 95-70-5.

Hapten info. T

Art. No.	Formula	FW	Series
TOLUENE-2,5-DIAMINE SULFATE			
D-002	$C_7H_{10}N_2H_2SO_4$	220.25	H

The primary intermediate in various permanent hair dyes Also known as 4-Toluenediamine, 2,5-Diaminotoluene sulfate and PTD. **CAS** 615-50-9.

Toluene-2,4-diisocyanate

T-009	$C_9H_6N_2O_2$	174.15	I
-------	----------------	--------	---

Used in the production of polyurethane foams, elastomers, adhesives, printing plates, etc. Also known as TDI. **May cause allergic asthma.** **CAS** 584-84-9.

Toluenesulfonamide formaldehyde resin

T-010	ICB, IS, PG, NA AC, NAE, NAC, LA		
-------	-------------------------------------	--	--

A modifier and adhesion promotor used for film forming natural and synthetic resins. Occurs in vinyl lacquers, nitrocellulose compositions (e.g., nail lacquers), PVA adhesives, acrylics. **CAS** 1338-51-8.

4-Tolyldiethanolamine

T-011	$C_{11}H_{17}NO_2$	195.26	DS
-------	--------------------	--------	----

An amine accelerator for the polymerization of e.g. dental acrylic composite restorative materials. **CAS** 3077-12-1.

Treemoss absolute

E-026	F		
-------	---	--	--

This is a chemical extract of the treemoss plant Evernia Furfuracea and oak moss. Used in perfumes, cosmetics, moisturizers, fragrance for men, body powder, sunscreen products, lipsticks, shampoos and soaps among others. The raw material for this product is made from an hexane extraction of the moss giving a concrete, then the absolute is obtained by extrating the concrete with ethanol. The moss used is Pseudevernia furfuracea & usnea barbata. Also known as Evernia furfuracea. **NOTE: The preparation is based on the raw material of treemoss absolute that has not been subject to chemical reduction of atranol and chloroatranol.** **CAS** 94944-93-1

Art. No.	Formula	FW	Series
Triamcinolone acetonide			
T-030	$C_{24}H_{31}FO_6$	434.49	CS, AC

A topical and systemic corticosteroid belonging to the group B (triamcinolone acetonide) type of steroids. **Cross: Budesonide, Fluocinolone acetonide, Hydrocortisone, Hydrocortisone-17-butyrate, Prednisolone Acetate, Tixocortol-21-Pivalate.** **CAS** 76-25-5.

3,4,5-Tribromosalicylanilide (TBS)

T-012	$C_{13}H_8Br_3NO_2$	449.96	6
-------	---------------------	--------	---

Abacteriostatic agent found in detergents and soaps, disinfectants, pet flea powders. Also known as Tribromsalan. **Cross (photo): Bithionol and other halogenated salicylanilides, TRICLOCARBAN, hexachlorophene, fentichlor.** **PA, PT.** **CAS** 87-10-5.

TRICLOCARBAN

T-013	$C_{13}H_9Cl_3N_2O$	315.59	O, EPE
-------	---------------------	--------	--------

a bacteriostat and antiseptic agent found in soaps and other cleansing compositions. Used as a disinfectant. Also known as 3,4,4-Trichlorocarbanilide and TCC. **Cross (photo): bithionol and other halogenated salicylanilides.** **PA. PT.** **May cause pigmentation of the face.** **CAS** 101-20-2.

TRICLOSAN

T-014	$C_{12}H_7Cl_3O_2$	289.53	C, O, EPE
-------	--------------------	--------	-----------

A preservative found in cosmetic products, soaps, detergents, shampoos, bath additives, deodorants, foot powders and sprays, disposable paper products, antiodor insoles and hose, laundry products. Also used in the treatment of textiles and as antifungal agent in PVC wetroom carpets. Also known as Irgasan DP 300. **PA.** **CAS** 3380-34-5.

Tricresyl phosphate

T-015	$C_{21}H_{21}O_4P$	368.36	PG
-------	--------------------	--------	----

A plasticizer found in vinyl plastics, spectacle frames. Used as a flame retardant and additive to extreme pressure lubricants. Can also be used as solvent for nitrocellulose, etc. **CAS** 1330-78-5.

Art. No.	Formula	FW	Series
TRIETHANOLAMINE			
T-016	$C_6H_{15}NO_3$	149.19	ICB, C, O, LU

A surface-active agent found in soaps, shampoos, creams, waxes, cutting oils etc. Used in making emulsions with mineral and vegetable oils. **CAS** 102-71-6.

Triethylene glycol diacrylate

T-017	$C_{12}H_{18}O_6$	258.28	MN, MP
-------	-------------------	--------	--------

A cross-linking acrylate monomer used in coatings, adhesives, and in printing plates of photoprepolymer type. Also known as TEGDA. **CAS** 1680-21-3.

Triethylene glycol dimethacrylate			
T-018	$C_{14}H_{22}O_6$	286.33	DS, MA, MN, MP, DMP, DMS

A methacrylic monomer used as cross-linking agent for adhesives and dental restorative materials. Also known as TEGDMA and TREGDMA. **CAS** 109-16-0

Triethylenetetramine

T-019	$C_6H_{18}N_4$	146.23	E
-------	----------------	--------	---

Used as epoxy curing agent, lubricating oil additive, chelating and analytical agent. Also known as TETA. **CAS** 112-24-3.

Triglycidyl isocyanurate

T-028	$C_{12}H_{15}N_3O_6$	297.27	PG
-------	----------------------	--------	----

Trifunctional epoxy compound used as cross-linker in heat-cured polyester paints used for laminated sheetings, printed circuits, tools, inks, adhesives, lining materials etc. Also known as TGIC. **May cause airborne contact dermatitis.** **CAS** 2451-62-9.

2,2,4-Trimethyl-1,2-dihydroquinoline

T-020	$(C_{12}H_{15}N)_n$		R
-------	---------------------	--	---

An antioxidant used in rubber and plastic materials. Also used in hydraulic fluids and greases. Also known as Flectol H and Agerite resin D. **CAS** 26780-96-1

Art. No.	Formula	FW	Series
Trimethylolpropane triacrylate			
T-021	$C_{15}H_{20}O_6$	296.31	MN, MP

A triacrylate used in UV-curable lithographic inks, varnishes, artificial nails, wood finish solder, and etch resists in the electronics industry. Also known as TMPTA. **CAS** 15625-89-5.

Trimethylolpropane triglycidyl ether

T-038	$C_{15}H_{26}O_6$	302.36	E
-------	-------------------	--------	---

A trifunctional glycidyl ether of trimethylolpropane. It is used as a general purpose diluent to reduce the viscosity of epoxy resins and provides excellent crosslinking with good reactivity used in adhesives and coatings. **CAS** 30499-70-8.

3,4,4-Trimethyl-oxazolidine

Comp. in D-015	$C_6H_{15}NO$	115.18	O
----------------	---------------	--------	---

Component in Bioban CS 1135, a preservative (2.5%) used in latex paints, resin emulsions, and cooling fluids. D-015: **Bioban CS 1135**: also contains 4,4-Dimethyloxazolidine. Neither of the substances can be ordered separately.

2,4,6-Tris(dimethylaminomethyl)phenol

T-048	$C_{15}H_{27}N_3O$	265.39	E
-------	--------------------	--------	---

This chemical is a tertiary amine activator for epoxy resins. Used in coatings, flooring, adhesives, castings, potting and encapsulation. **CAS** 90-72-2.

TRIS(HYDROXYMETHYL)NITROMETHANE

H-015	$C_4H_9NO_5$	151.12	O
-------	--------------	--------	---

A bactericide and slimicide used in cooling fluids, paper and pulp industry. Also used as curing agent for certain adhesives. Also known as Tris Nitro and 2-Hydroxymethyl-2-nitro-1,3-propanediol. **CAS** 126-11-4.

Triphenyl phosphate

T-022	$C_{18}H_{15}O_4P$	326.28	PG
-------	--------------------	--------	----

A plasticizer in plastics (e.g., cellulose acetate) lacquers, varnishes, etc. Also used in impregnating roofing paper. **CAS** 115-86-6.

Art. No.	Formula	FW	Series
Tri(propylene glycol) diacrylate			
T-023	$C_{15}H_{24}O_6$	300.36	MP

A diacrylate monomer for use in UV-curable flexographic and silk screen inks, wood-finish varnishes, coatings on plastics, etc. Also known as TPGDA. **CAS** 42978-66-5.

Tungsten

T-043	W	183.84	MET
-------	---	--------	-----

Tungsten, also known as Wolfram, is a metal with a wide range of uses, the largest of which is as Tungsten carbide (W₂C, WC) in cemented carbides. Cemented carbides (also called hardmetals) are wear-resistant materials used by the metalworking, mining, petroleum and construction industries. Tungsten is widely used in light bulb and vacuum tube filaments, as well as electrodes, because it can be drawn into very thin wire with a high melting point. Tungsten is used in material for implanted electrodes and in orthopaedic and dental implants as well as in coils to treat intracranial aneurysms. **CAS** 7440-33-7

Turpentine oil oxidized

T-024	C		
-------	---	--	--

Mixture of hydroperoxides of terpenes found in oil of turpentine. Main hapten is the hydroperoxide of δ-3-carene. Used in solvents or lacquers for printing, etching and art painting. Found in sealing wax, coolants, tapes, polish, metal cleaners, deodorizers, paints, and cosmetics. **Cross: Chrysanthemum, pyrethrin. May cause airborne contact dermatitis.**

U

Urea formaldehyde resin

U-001	$C_3H_8N_2O_3$	120.11	TF
-------	----------------	--------	----

A textile finish resin of formaldehyde type for treatment of, e.g., cotton and rayon materials. Also used in wood glue industry. **CAS** 9011-05-6.

Urethane diacrylate, aliphatic

Deleted 2019		1500	
--------------	--	------	--

An UV-reactive prepolymer based on an acrylated aliphatic isocyanate. Used in curable coatings, inks, and varnishes.

210

Art. No.	Formula	FW	Series
Urethane diacrylate, aromatic			
Deleted 2019		1000	

An UV-reactive prepolymer based on an acrylated aromatic isocyanate. Used in curable coatings, inks and varnishes. Also known as Ebecryl 220. Contains also pentaerythritoltriacylate and pentaerythritoltetraacylate.

Urethane dimethacrylate

U-004	$C_{23}H_{38}N_2O_8$	470.56	DS, MA
-------	----------------------	--------	--------

A methacrylate based on a methacrylated aliphatic isocyanate. Used in dental bonding agents, resin veneering, and restorative materials Also known as UDMA. **CAS** 72869-86-4.

(+)-Usnic acid

U-005	$C_{18}H_{16}O_7$	344.31	PL
-------	-------------------	--------	----

An antibacterial substance found in many lichens. Occurs in oak moss absolute which is used as fragrance. Used as a preservative in deodorants, antiacne formulations, and as antibiotic for topical application. Also available as part of Mx-15. **Cross: oak moss. May cause airborne contact dermatitis. CAS** 7562-61-0

V

Vanadium

V-002	V	50.94	MET
-------	---	-------	-----

Vanadium is soft and ductile element, which occurs naturally in certain minerals and is used mainly to produce certain alloys. Approximately 80% of Vanadium produced is used as ferrovandium or as a steel additive. Other uses: In such alloys as specialty stainless steel, e.g. for use in surgical instruments and tools. Such tools are rust resistant and high speed tool steels. Mixed with aluminium in Titanium alloys used in jet engines and high-speed airframes. Used in dental alloys. Vanadium steel alloys are used in axles, crankshafts, gears, and other critical components. It is an important carbide stabilizer in making steels. Vanadium foil is used in cladding Titanium to steel. **CAS** 7440-62-2.

Art. No.	Formula	FW	Series
Vanadium(III)chloride			
V-003	VCl ₃	157.30	MET

This hapten is a marker for contact allergy to **vanadium**. Used as a catalyst in the polymerization of olefins, epoxy, phenolic and silicone resins. For testing purpose this is also used to test allergy for Vanadium. Vanadium is used in applications for bicycle parts, glass coatings and jewelry. It can also be found in dental implants. **CAS** 7718-98-1.

Vanadium(V)oxide			
V-005	V ₂ O ₅	181.88	MET

This hapten is a marker for contact allergy to **vanadium**. A principal precursor to alloys of vanadium and is a widely used as an industrial catalyst. It can also be found in air care products, floor coverings, paints and coatings. For testing purpose this is also used to test allergy for Vanadium. Vanadium is used in applications for bicycle parts, glass coatings and jewelry. It can also be found in dental implants. **CAS** 1314-62-1.

Vancomycin hydrochloride			
V-004	C ₆₆ H ₇₅ C ₁₂ N ₉ O ₂₄ ·HCl	1485.71	ME

This substance is an antibiotic used to treat a number of bacterial infections. It is used as a first-line treatment for complicated skin infections, bloodstream infections, endocarditis, bone and joint infections, and meningitis caused by methicillin-resistant S. aureus. **CAS** 1404-93-9.

VANILLIN			
V-001	C ₈ H ₈ O ₃	152.14	B, F

A flavoring agent found in beverages, confectionery, foods, galenicals. Used in perfumery, pharmaceuticals and also as chemical reagent. Also known as Vanillin. **Cross: COUMARIN, Propolis. ICU. CAS** 121-33-5.

W

Art. No.	Formula	FW	Series
X			
m-Xylylenediamine			
X-001	C ₈ H ₁₂ N ₂	136.19	E

The chemical is an intermediate in the production of epoxy curing agents, polyamides and polyurethanes. Due to the chemical binding processes that occur during curing, finished products do not contain the chemical. The substance is also not present in the industrial intermediates used in the production of polyamides and polyurethanes, but a few percent is present in the epoxy curing agent. The great majority of the epoxy curing agent is assumed to be used by industrial or professional users. Greater than 99.9% of the substance is used in three categories: polyamide (major), epoxy curing agent, and polyurethane production. Also known as 1,3-bis(aminomethyl)benzene. **CAS** 1477-55-0.

Y

Ylang ylang oil			
Y-001			ICB, F, NA, NAE, NAC, AC

This substance is used in soap perfumes and in general perfumery as a floral additive of extremely versatile application. It blends with almost any other floral natural or synthetic material and gives good effects in a concentration of 0.5% up to about 5% of the perfume base. The fragrance is also used in washing detergents, hair products and skin powder. The oil is steam distilled from the flowers of *Cananga odorata* genuine. Fractions of the oil are collected over the course of distillation to obtain different grades. The first and finest fraction is called ylang-ylang oil. The oil has a very sweet tropical floral scent, smells like a combination of Jasmine and bitter almond-peppermint. Main chemical components are Linalool, p-Cresyl methyl ether, beta-Caryophyllene, Geranyl acetate, Methyl benzoate, Benzyl benzoate, Farnesol, Geraniol, Isoeugenol, Eugenol and Citral. Also known as CANANGA ODORATA OIL. **Cross: Benzyl salicylate, geraniol. May cause pigmentation of the face. CAS** 8006-81-3.

Art. No.	Formula	FW	Series
----------	---------	----	--------

Z

Zinc

Z-001	Zn	65.38	MET
-------	----	-------	-----

Zinc metal is included in most single tablet over-the-counter daily vitamin and mineral supplements. Zinc is the fourth most common metal in use, trailing only iron, aluminium, and copper in annual production. Zinc is used to galvanize steel to prevent corrosion. Zinc is used to Parkerize steel to prevent rust and corrosion and used in alloys such as brass, nickel silver, dental alloys, typewriter metal and various soldering formulas. Zinc is the primary metal used in making some coins and used in die casting notably in the automobile industry. Zinc is used as part of the containers of batteries. The most widespread such use is as the anode in alkaline batteries. **CAS** 7440-66-6.

ZINC CHLORIDE

Z-007	Cl ₂ Zn	136.28	MET
-------	--------------------	--------	-----

This hapten is a marker for contact allergy to **zinc**. Other uses are as a deodorant and as a wood preservative. **CAS** 7646-85-7.

ZINC DIBUTYLDITHIOCARBAMATE

Z-002	C ₁₈ H ₃₆ N ₂ S ₄ Zn	474.14	R
-------	--	--------	---

An activator, antidegradant and accelerator for natural rubber, butadiene, styrene-butadiene, nitrile-butadiene, butyl rubber, and ethylene-propylene-diene terpolymers. Also known as ZBC. Also available as part of Mx-06. **CAS** 136-23-2.

Zinc diethyldithiocarbamate

Z-003	C ₁₀ H ₂₀ N ₂ S ₄ Zn	361.91	R
-------	--	--------	---

An activator and accelerator for natural rubber, styrene-butadiene, nitrile-butadiene, and butyl rubber. Also known as ZDC. Also available as part of Mx-06. **ICU CAS** 14324-55-1.

Art. No.	Formula	FW	Series
----------	---------	----	--------

Zinc dimethyldithiocarbamate

Z-004	C ₆ H ₁₂ N ₂ S ₄ Zn	305.82	R
-------	---	--------	---

An activator and accelerator for natural rubber, styrene-butadiene, and butyl rubber. An agricultural fungicide used for seeds, plants, and fruit. Also known as Ziram. **CAS** 137-30-4.

Zinc ethylenebis-(dithiocarbamate) (Zineb)

Z-005	C ₄ H ₆ N ₂ S ₄ Zn	275.75	O
-------	--	--------	---

A fungicide used in cooling fluids and as pesticide for seeds, plants, and fruit. Also known as Zineb. **CAS** 12122-67-7.

ZINC PYRITHIONE

Z-006	C ₁₀ H ₈ N ₂ S ₂ O ₂ Zn	317.70	H
-------	--	--------	---

An antifungal, antibacterial and antiseborrheic agent used in many shampoos and hair creams. Also known as Zinc omadine. **Reactions may lead to photosensitive eczema and actinic reticuloid syndrome.** **CAS** 13463-41-7.

Zirconium(IV)chloride

Z-008	Cl ₄ Zr	233.03	MET
-------	--------------------	--------	-----

This hapten is a marker for contact allergy to **zirconium**. This metal salt is a white high-melting solid which hydrolyzes rapidly in humid air. It is used to make water-repellent textiles and can also be used in implants. **CAS** 10026-11-6

ZIRCONIUM DIOXIDE

Z-009	ZrO ₂	123.22	MET
-------	------------------	--------	-----

This hapten is a marker for contact allergy to zirconium. This chemical is a ceramic material and the most natural form of the element Zirconium. It is found in insulation, abrasives, enamels, ceramic glazes, and as diamond substitute in jewelry. It is also used in the construction of dental restorations such as crowns and bridges. It can also be used as radio-opaque material in bone cement. In orthopedic surgery bone cement is used to fix metal implants such as hip- and knee replacements. **CAS** 1314-23-4.

Catalogue amendments January 2020

New topical haptens

		In Series
I-019	ISOBORNYL ACRYLATE 0.1% pet	MA, MP
Mx-28B	Gallate mix 1.0% pet	B, C

Deleted topical haptens

		In Series
A-006A	PABA 5.0% pet	NAP
A-006B	PABA 5.0% alc	NAP
B-029B	BUTYL METHOXYDIBENZOYL METHANE 5.0% pet	NAP
C-027	Cyclohexanone resin 1.0% pet	PG
D-029	Disperse Blue 153 1.0% pet	TF
E-001	Epoxy acrylate 0.5% pet	MP
E-018B	ETHYLHEXYL DIMETHYL PABA 5.0% pet	NAP
E-018C	ETHYLHEXYL DIMETHYL PABA 5.0% alc	NAP
E-019B	ETHYLHEXYL METHOXYCINNAMATE 7.5% pet	NAP
E-020	Epoxy resin, Cycloaliphatic 0.5% pet	E
H-023B	BENZOPHENONE-4 10.0% pet	NAP, SF
I-001B	IMIDAZOLIDINYL UREA 2.0% aq	IS
L-007	Lead(II)acetate trihydrate 0.5% aq	MET
M-029	Minocycline hydrochloride 10.0% pet	CAD
Mx-21C	Dermatophagoides mix 30.0% pet	V
Mx-28	Gallate mix 1.5% pet	B, C
P-017A	Promethazine hydrochloride 1.0% pet	NAP
U-002	Urethane diacrylate, aliphatic 0.1% pet	MP
U-003	Urethane diacrylate, aromatic 0.05% pet	MP
H-006	HYDROGEN PEROXIDE 3.0% aq	H

Hapten Series Amendment

AC-1000	American Core Series added.
B-1000	No 20 Gallate mix 1.5% pet (Mx-28) changed to Gallate mix 1.0% pet (Mx-28B).
C-1000	No 60 Gallate mix 1.5% pet (Mx-28) changed to Gallate mix 1.0% pet (Mx-28B).
CAD-1000	No 6 Minocycline hydrochloride (M-029) deleted.
E-1000	No 7 Epoxy resin, Cycloaliphatic 0.5% pet (E-020) deleted.
GB-1000	Great Britain Baseline Series extended

IS-1000	September 2019. No 18 IMIDAZOLIDINYL UREA 2.0% aq (I-001B) changed to IMIDAZOLIDINYL UREA 2.0% pet (I-001A).
MA-1000	No 16 ISOBORNYL ACRYLATE 0.1% pet (I-019) added.
MET-1000	No 6 Cobalt(II)chloride hexahydrate 1.0% pet (C-017A) added.
MET-1000	No 36 Lead(II)acetate trihydrate 0.5% aq (L-007) changed to Nickel(II)sulfate hexahydrate 5.0% pet (N-002A).
MET-1000	No 55 Potassium dichromate 0.5% pet (P-014A) added.
MP-1000	No 20 Epoxy acrylate 0.5% pet (E-001) changed to ISOBORNYL ACRYLATE 0.1% pet (I-019).
MP-1000	No 21 Urethane diacrylate, aliphatic 0.1% pet (U-002) changed to Triethylene glycol diacrylate 0.1% pet (T-017).
MP-1000	No 22 Urethane diacrylate, aromatic 0.05% pet (U-003) changed to N,N-Methylene-bisacrylamide 1.0% pet (M-023).
MP-1000	No 23 Triethylene glycol diacrylate 0.1% pet (T-017) deleted.
MP-1000	No 24 N,N-Methylene-bisacrylamide 1.0% pet (M-023) deleted.
NAP-1000	No 1 ETHYLHEXYL METHOXYCINNAMATE 7.5% pet (E-019B) changed to ETHYLHEXYL METHOXYCINNAMATE 10.0% pet (E-019C).
NAP-1000	No 2 BENZOPHENONE-4 10.0% pet (H-023B) changed to BENZOPHENONE-4 2.0% pet (H-023C).
NAP-1000	No 10 PABA 5.0% alc (A-006B) changed to PABA 10.0% pet (A-006C).
NAP-1000	No 13 ETHYLHEXYL DIMETHYL PABA 5.0% alc (E-018C) changed to 10.0% pet (E-018D).
NAP-1000	No 15 Promethazine hydrochloride 1.0% pet (P-017A) changed to Promethazine hydrochloride 0.1% pet (P-017B).
NAP-1000	No 16 ETHYLHEXYL DIMETHYL PABA 5.0% pet (E-018B) changed to METHYLANTHRANILATE 5.0% pet (M-028).
NAP-1000	No 18 PABA 5.0% pet (A-006A) changed to 6-METHYL COUMARIN 1.0% alc (M-010B).
NAP-1000	No 23 METHYLANTHRANILATE 5.0% pet (M-028) deleted.
NAP-1000	No 24 6-METHYL COUMARIN 1.0% alc (M-010B) deleted.
PCB-1000	Polish Comprehensive Baseline Series added July 2019.

PG-1000	No 24 Cyclohexanone resin 1.0% pet (C-027) changed to Triglycidyl isocyanurate (TGIC) 0.5% pet (T-028).
PG-1000	No 25 Triglycidyl isocyanurate (TGIC) 0.5% pet (T-028) deleted.
POL-1000	Polish Baseline Series revised July 2019.
SF-1000	Swedish Photopatch Series deleted.
TF-1000	No 5 Disperse Blue 153 1.0% pet (D-029) deleted.
V-1000	No 37 Dermatophagoides mix 30.0% pet (Mx-21C) deleted August 2019.
H-1000	No 12 HYDROGEN PEROXIDE 3.0% aq (H-006) deleted December 2019.

Catalogue amendments January 2021

New topical haptens

In Series

C-009E	METHYLISOTHIAZOLINONE+ METHYLCHLOROISOTHIAZOLINONE 0.215% aq	IS
Mx-05C	Mercapto mix 3.5% pet	IS

Deleted products

In Series

C-017B	Cobalt(II)chloride hexahydrate 0.5% pet	SS, DMP
SMUV	Skin Marker UV	N/A
SMS	Skin Marker Slim	N/A
UV-LAMP	UV Lamp	N/A

Hapten Series Amendment

DMP-1000	No 13 Cobalt(II)chloridehexahydrate0.5% pet (C-017B) changed to Cobalt(II)chloride hexahydrate 1.0% pet (C-017A).
IS-1000	No 9 Mercapto mix 2.0 pet% (Mx-05A) changed to Mercapto mix 3.5% pet (Mx-05C)
IS-1000	No 14 2-Mercaptobenzothiazole (MBT) 2.0% pet (M-003A) changed to Textile dye mix 6.6% pet (Mx-30)
IS-1000	No 17 METHYLISOTHIAZOLINONE+ METHYLCHLOROISOTHIAZOLINONE 0.02% aq (C-009B) changed to METHYLISOTHIAZOLINONE+ METHYLCHLOROISOTHIAZOLINONE 0.215% aq (C-009E)
IS-1000	No 26 Hydrocortisone-17-butyrate 1.0% pet (H-021B) changed to Phenol formaldehyde resin (PFR2) 1.0%

pet	(P-005)
IS-1000	No 31 Toluenesulfonamide formaldehyde resin 10.0% pet (T-010) deleted
IS-1000	No 32 METHYLISOTHIAZOLINONE 0.2 aq (M-035B) deleted
AC-1000	No 19 METHYLDIBROMO GLUTARONITRILE 0.5% pet (D-049E) changed to Hydroperoxides of Linalool 0.5% pet (H-031B)
AC-1000	No 21 FORMALDEHYDE 1.0% aq (F-002A) changed to FORMALDEHYDE 2.0% aq (F-002B)
AC-1000	No 59 p-CHLORO-m-CRESOL 1.0% pet (C-008) changed to Hydroperoxides of Limonene 0.2% pet (H-032B)
AC-1000	No 60 BENZALKONIUM CHLORIDE 0.1% aq (B-027A) changed to BENZALKONIUM CHLORIDE 0.1% pet (B-027B)
AC-1000	No 69 CETEARYL ALCOHOL 20.0% pet (C-033) changed to HYDROXYISOHEXYL 3-CYCLOHEXENE CARBOXYALDEHYDE 5.0% pet (L-003)
AC-1000	No 81 CETEARYLALCOHOL 20.0% pet (C-033) added
AC-1000	No 82 left blank
AC-1000	No 83 BENZYL SALICYLATE 10.0% pet (B-010B) added
AC-1000	No 84 Disperse Yellow 3 1.0% pet (D-036) added
AC-1000	No 85 Jasmine absolute 2.0% pet (J-002) added
AC-1000	No 86 Peppermint oil 2.0% pet (P-036) added
AC-1000	No 87 Pramoxine hydrochloride 2.0% pet (P-039) added
AC-1000	No 88 SHELLAC 20.0% alc (S-015) added
AC-1000	No 89 LAURYL POLYGLYCOSIDE 3.0% pet (L-004) added
AC-1000	No 90 p-CHLORO-m-CRESOL 1.0% pet (C-008) added

For all previous amendments, please visit www.chemotechnique.se

Catalogue amendments January 2022

New products

In Series

C-059	Carmines (CI) 2.5% pet	AC-82
SMM-4	Chemo Skin marker Medium	N/A
IMP-1000	Implant Series	IMP
METE-1000	Metal Extended Series	METE

Deleted products		In Series		
A-018	Azodiisobutyrodinitrile 1.0% pet	PG	E-1000	No 7 m-Xylylenediamine 0.1% pet (X-001) moved from pos. 13 to 7.
A-020	Amylocaine hydrochloride 5.0% pet	N/A	E-1000	No 11 1,6-Hexanediol diglycidylether 0.25% pet (H-026) changed to 2,4,6-Tris(dimethylaminomethyl)phenol 0.5% pet (T-048)
B-020	BUTYLPARABEN 3.0% pet	N/A	E-1000	No 12 1,4-Butanediol diglycidyl ether 0.25% pet (B-036) deleted
B-036	1,4-Butanediol diglycidyl ether 0.3% pet	E	E-1000	No 14 Trimethylolpropane triglycidyl ether 0.25% pet (T-038) deleted
C-009D	METHYLISOTHIAZOLINONE+ METHYLCHLOROISOTHIAZOLINONE 0.2% pet	N/A	E-1000	No 15 2,4,6-Tris(dimethylaminomethyl)phenol 0.5% pet (T-048) moved to pos. 11.
C-011	Chlorpromazine hydrochloride 0.1% pet	EPE,NAP	EP-1000	No 19 Promethazine hydrochloride 0.1% pet (P-017B) deleted and changed to DECYL GLUCOSIDE 5.0% pet (D-065)
C-012	Chlorquinaldol 5.0% pet	N/A	EP-1000	No 20 DECYL GLUCOSIDE 5.0% pet (D-065) moved to pos. 19.
D-044B	DIAZOLIDINYL UREA 2.0% aq	SS, INC	EPE-1000	No 1 BENZOPHENONE-3 10.0% pet (H-014C) changed to TRICLOCARBAN 1.0% pet (T-013)
D-061A	Diclofenac sodium salt 1.0% pet	CAD	EPE-1000	No 2 BENZOPHENONE-4 2.0% pet (H-023C) changed to BENZOPHENONE-10 10.0% pet (H-020B)
D-067	Dexketoprofen 1.0% pet	EPE	EPE-1000	No 3 4-METHYLBENZYLIDENE CAMPHOR 10.0% pet (M-024B) changed to PHENYLBENZIMIDAZOLE SULFONIC ACID 10.0% pet (P-024B)
E-009	2-Ethylhexyl acrylate 0.1% pet	MP	EPE-1000	No 4 ETHYLHEXYL METHOXYCINNAMATE 10.0% pet (E-019C) changed to HOMOSALATE 10.0% pet (H-024B)
H-017	Hydroxypropyl acrylate 0.1% pet	MP	EPE-1000	No 5 OCTOCRYLENE 10.0% pet (O-009) changed to ETHYLHEXYL SALICYLATE 10.0% pet (O-007B)
H-026	1,6-Hexanediol diglycidylether 0.3% pet	E	EPE-1000	No 6 ISOAMYL p-METHOXYCINNAMATE 10.0% pet (I-009) changed to Polysilicone-15 10.0% pet (P-035)
M-012	METHYLPARABEN 3.0% pet	N/A	EPE-1000	No 7 PABA 10.0% pet (A-006C) changed to Disodium phenyl dibenzimidazole tetrasulfonate 10.0% pet (D-064)
M-018	MUSK KETONE 1.0% pet	F	EPE-1000	No 8 BUTYL METHOXYDIBENZOYLMETHANE 10.0% pet (B-029C) changed to TRICLOSAN 2.0% pet (T-014)
M-035A	METHYLISOTHIAZOLINONE 0.02% aq	N/A	EPE-1000	No 9 BIS-ETHYLHEXYLPHENOL METHOXYPHENOL TRIAZINE 10.0% pet (B-037) changed to Ibuprofen 5.0% pet (I-010B)
M-035C	METHYLISOTHIAZOLINONE 0.05% aq	BS	EPE-1000	No 10 DROMETRIZOLE TRISILOXANE 10.0% pet (D-055) changed to Diclofenac sodium salt 5.0% pet (D-061B)
Mx-08	Perfume mix 6.0% pet	F	EPE-1000	No 11 Ketoprofen 1.0% pet (K-002B) changed to Fenofibrate 10.0% pet (F-006)
O-003	Oligotriacrylate (OTA 480) 0.1% pet	MP	EPE-1000	No 12 2-(4-Diethylamino-2-hydroxybenzoyl)-benzoic acid hexylester 10.0% pet (D-062) changed to Olaquinox
P-002	Pentaerythritol triacrylate 0.1% pet	MP		
P-017B	Promethazine hydrochloride 0.1% pet	EP,EPE,NAP		
P-020	PROPYLPARABEN 3.0% pet	N/A		
P-032	Pristinamycin 10.0% pet	CAD		
SM	Chemo Skin Marker-Regular	N/A		
SMS	Chemo Skin Marker-Slim	N/A		
T-012	3,4,5-Tribromosalicylanilide (TBS) 1.0% pet	NAP		
T-038	Trimethylolpropane triglycidyl ether 0.3% pet	E-14		
Hapten Series Amendment				
CAD-1000	No 1 Cefixime trihydrate 10.0% pet (C-054) moved from pos. 32 to 1.			
CAD-1000	No 6 Cefpodoxime proxetil 10.0% pet (C-055) moved from pos. 34 to 6.			
CAD-1000	No 10 Pristinamycin 10.0% pet (P-032) changed to Potassium clavulanate 10.0% pet (P-040).			
CAD-1000	No 19 Diclofenac sodium salt 1.0% pet (D-061A) changed to Diclofenac sodium salt 5.0% pet (D-061B)			
CAD-1000	No 35 Potassium clavulanate 10.0% pet (P-040) moved from pos. 35 to 10.			

1.0% pet (O-008)
 EPE-1000 No 13 to No 34 Deleted
 F-1000 No 13 MUSK KETONE 1.0% pet (M-018) deleted and
 changed to SORBITAN SESQUIOLEATE 20.0% pet
 (S-005)
 F-1000 No 45 Perfume mix 6.0% pet (Mx-08) deleted
 and changed to Fragrance mix I 8.0% pet (Mx-07)
 MA-1000 No 17 Ethyl acrylate 0.1% pet (E-004) added
 MA-1000 No 18 2-Hydroxyethyl acrylate 0.1% pet (H-009) added
 MA-1000 No 19 ETHYL METHACRYLATE 2.0 % pet (E-012)
 added
 MA-1000 No 20 2,2-bis(4-(2-Methacryl-oxyethoxy)phenyl)
 propane (BIS-EMA) 2.0 % pet (M-006B) added
 MA-1000 No 21 1,4-Butanediol diacrylate 0.1% pet (B-016)
 added
 MA-1000 No 22 Di(ethylene glycol) diacrylate 0.1% pet (D-009)
 added
 MA-1000 No 23 Tri(propylene glycol) diacrylate 0.1% pet
 (T-023) added
 MA-1000 No 24 Trimethylolpropane triacrylate 0.1% pet (T-021)
 added
 MA-1000 No 25 Triethylene glycol diacrylate 0.1% pet (T-017)
 added
 MA-1000 No 26 N,N-Methylene-bisacrylamide 1.0% pet (M-023)
 added
 MA-1000 No 27 Butyl acrylate 0.1% pet (B-018) added
 MET-1000 The series has been divided into two series MET-1000
 and METE-1000
 MN-1000 No 1 Butyl acrylate 0.1% pet (B-018) changed to Ethyl
 cyanoacrylate 10.0% pet (E-023)
 MN-1000 No 3 BUTYL METHACRYLATE 2.0% pet (B-021)
 changed to Methyl methacrylate 2.0% pet (M-013)
 MN-1000 No 7 Triethylene glycol dimethacrylate 2.0% pet (T-018)
 changed to Bisphenol A glycerolate dimethacrylate
 2.0% pet (H-013)
 MN-1000 No 9 Trimethylolpropane triacrylate 0.1% pet (T-021)
 changed to Triethylene glycol diacrylate 0.1% pet (T-017)
 MN-1000 No 13 Triethylene glycol diacrylate 0.1% pet (T-017)
 deleted
 MP-1000 Deleted 2021-10-30
 PG-1000 No 9 Azodiisobutyrodinitrile 1.0% pet (A-018) changed

to Triglycidyl isocyanurate (TGIC) 0.5% pet (T-028)
 PG-1000 No 24 Triglycidyl isocyanurate (TGIC) 0.5% pet
 (T-028) deleted
 AC-1000 No 82 Carmine (CI) 2.5% pet (C-059) added

For all previous amendments, please visit www.chemotechnique.se